

[THURSDAY, JUNE 15, 1882

CHARLES DARWIN¹

IV.

IN attempting to estimate the influence which Mr. Darwin's writings have exerted on the progress of botanical science, a little consideration will show that we must discriminate between the indirect effect which his views have had on botanical research generally, and the direct results of his own contributions. No doubt in a sense the former will seem in the retrospect to overshadow the latter. For in his later writings Mr. Darwin was content to devote himself to the consideration of problems—with an insight and patience essentially his own—which, in a limited field, brought his theoretical views to a detailed test, and so may ultimately seem to be somewhat merged in them. It is wonderful enough that so great a master in biological science should, at an advanced age, have been content to work with all the fervour and assiduity of youth at phenomena of vegetable life apparently minute and of the most special kind. But to him they were not minute, but instinct with a significance that the professed botanical world had for the most part missed seeing in them failing the point of view which Mr. Darwin himself supplied. It is not too much to say that each of his botanical investigations, taken on its own merits, would alone have made the reputation of any ordinary botanist.

Mr. Darwin's attitude towards botany, as indeed to biological studies generally, it should always be remembered was in his early life essentially that of a naturalist of the school of Linnæus and Humboldt—a point of view unfortunately now perhaps a little out of fashion. Nature in all its aspects spoke to his feelings with a voice that was living and direct. The writer of these lines can well remember the impression which it made upon him to hear Mr. Darwin gently complain that some of this warm enthusiasm for nature, as it presents itself unanalysed to ordinary healthy vision, seemed to be a little dulled in the younger naturalists of the day, who were apt to be somewhat cramped by the limits of their work-rooms. The pages of the "Journal of Researches" show no such restraint, but abound with passages in which Mr. Darwin's ever unstudied and simple language is carried by the force of warm impression and a perfect joy in nature to a level of singular beauty. One passage may be quoted as an illustration; it is from the description of Bahia in Chapter xxi. :—

"When quietly walking along the shady pathways, and admiring each successive view, I wished to find language to express my ideas. Epithet after epithet was found too weak to convey to those who have not visited the inter-tropical regions, the sensation of delight which the mind experiences. I have said that the plants in a hothouse fail to communicate a just idea of the vegetation, yet I must recur to it. The land is one great wild, untidy, luxuriant hothouse, made by Nature for herself, but taken possession of by man, who has studded it with gay houses and formal gardens. How great would be the desire in every admirer of nature to behold, if such were possible, the scenery of another planet! Yet to every person in Europe, it may be truly said, that at the dis-

¹Continued from p. 100.

tance of only a few degrees from his native soil, the glories of another world are opened to him. In my last walk I stopped again and again to gaze on these beauties, and endeavoured to fix in my mind for ever, an impression which at the time I knew sooner or later must fail. The form of the orange-tree, the cocoa-nut, the palm, the mango, the tree-fern, the banana, will remain clear and separate; but the thousand beauties which unite these into one perfect scene must fade away; yet they will leave, like a tale heard in childhood, a picture full of indistinct, but most beautiful figures."

A spirit such as this, penetrating an intelligence such as Mr. Darwin's, would not content itself with the superficial interest of form and colour. These, in his eyes, were the outward and visible signs of the inner *arcana*. The fascination of sense which the former imposed upon him but stimulated his desire to unveil the latter. In the Galapagos we are not then surprised to find him ardently absorbed in the problems which the extraordinary distribution of the plants, no less than of other organisms, presented :—

"I indiscriminately collected everything in flower on the different islands, and fortunately kept my collections separate."

After tabulating the results which they yielded after systematic determination, he proceeds :

"Hence we have the truly wonderful fact, that in James Island, of the thirty-eight Galapageian plants, or those found in no other part of the world, thirty are exclusively confined to this one island; and in Albemarle Island, of the twenty-six aboriginal Galapageian plants, twenty-two are confined to this one island, that is, only four are known to grow on the other islands of the Archipelago; and so on, as shown in the above table, with the plants from Chatham and Charles Island."

It is impossible in reading the Origin of Species not to perceive how deeply Mr. Darwin had been impressed by the problems presented by such singularities of plant distribution as he met with in the Galapagos. And of such problems up to the time of its publication no intelligible explanation had seemed possible. Sir Joseph Hooker had indeed prepared the ground by bringing into prominence, in numerous important papers, the no less striking phenomena which were presented when the vegetation of large areas came to be analysed and compared. No one therefore could estimate more justly what Mr. Darwin did for those who worked in this field. How the whole matter stood after the publication of the Origin of Species cannot be better estimated than from the summary of the position contained in Sir Joseph Hooker's recent address to the Geographical Section of the meeting of the British Association at York.

"Before the publication of the doctrine of the origin of species by variation and natural selection, all reasoning on their distribution was in subordination to the idea that these were permanent and special creations; just as, before it was shown that species were often older than the islands and mountains they inhabited, naturalists had to make their theories accord with the idea that all migration took place under existing conditions of land and sea. Hitherto the modes of dispersion of species, genera, and families had been traced, but the origin of representative species, genera, and families, remained an enigma; these could be explained only by the supposition that the localities where they occurred presented conditions so similar that they favoured the creation of similar organisms which failed to account for representation, occurring in

the far more numerous cases where there is no discoverable similarity of physical conditions, and of their not occurring in places where the conditions are similar. Now under the theory of modification of species after migration and isolation, their representation in distant localities is only a question of time, and changed physical conditions. In fact, as Mr. Darwin well sums up, all the leading facts of distribution are clearly explicable under this theory; such as the multiplication of new forms, the importance of barriers in forming and separating zoological and botanical provinces; the concentration of related species in the same area; the linking together under different latitudes of the inhabitants of the plains and mountains, of the forests, marshes, and deserts, and the linking of these with the extinct beings which formerly inhabited the same areas; and the fact of different forms of life occurring in areas having nearly the same physical conditions."

If Mr. Darwin had done no more than this in the botanical field he would have left an indelible mark on the progress of botanical science. But the consideration of the various questions which the problem of the Origin of Species presented led him into other inquiries in which the results were scarcely less important. The key-note of a whole series of his writings is struck by the words with which the eighth chapter of the Origin of Species commences:—

"The view generally entertained by naturalists is that species, when intercrossed, have been specially endowed with the quality of sterility, in order to prevent the confusion of all organic forms."

The examination of this principle necessarily obliged him to make a profound study of the conditions and limits of sterility. The results embodied in his well-known papers on dimorphic and trimorphic plants afforded an absolutely conclusive proof that sterility was not inseparably tied up with specific divergence. But the question is handled in the most judicial way, and when the reader of the chapter on hybridism arrives at the concluding words in which Mr. Darwin declares that on this ground "there is no fundamental distinction between species and varieties," he finds himself in much the same intellectual position as is produced by the Q.E.D. at the end of a geometrical demonstration.

It was characteristic of Mr. Darwin's method to follow up on its own account, as completely as possible, when opportunity presented, any side issue which had been raised apparently incidentally in other discussions. Indeed it was never possible to guess what amount of evidence Mr. Darwin had in reserve behind the few words which marked a mere step in an argument. It was this practice of bringing out from time to time the contents of his unseen treasure-house which affords some insight into the scientific energy of his later years, at first sight so inexplicably prolific. Many of his works published during that period may be properly regarded in the light of excursions on particular points of his great theory. The researches on the sexual phenomena of heterostyled plants, alluded to above, which were communicated to the Linnean Society in a series of papers ranging over the years 1862-8, ultimately found their complete development in the volume "On the Different Forms of Flowers or Plants of the same Species," published in 1877. In the same way, the statement in the Origin of Species, that "the crossing of forms only slightly dif-

ferentiated, favours the vigour and fertility of their offspring," finds its complete expansion in "The Effects of Cross and Self-Fertilisation in the Vegetable Kingdom," published in 1876.

The "Origin of Species" in the form in which it has become a classic in scientific literature was originally only intended as a preliminary *précis* of a vast accumulation of facts and arguments which the author had collected. It was intended to be but the precursor of a series of works in which all the evidence was to be methodically set out and discussed. Of this vast undertaking only one, the "Variation of Plants and Animals under Domestication" was ever actually published. Apart from its primary purpose it produced a profound impression, especially on botanists. This was partly due to the undeniable force of the argument from analogy stated in a sentence in the introduction:—"Man may be said to have been trying an experiment on a gigantic scale; and it is an experiment which nature, during the long lapse of time has incessantly tried." But it was still more due to the unexpected use of the vast body of apparently trivial facts and observations which Mr. Darwin with astonishing industry had disinterred from weekly journals and ephemeral publications of all sorts and unexpectedly forced into his service. Like Molière's Monsieur Jourdain, who was delighted to find that he had been unwittingly talking prose all his life, horticulturists who had unconsciously moulded plants almost at their will at the impulse of taste or profit were at once amazed and charmed to find that they had been doing scientific work and helping to establish a great theory. The criticism of practical men, at once most tenacious and difficult to meet, was disarmed; these found themselves hoist with their own petard. Nor was this all. The exclusive province of science was in biological phenomena for ever broken down; every one whose avocations in life had to do with the rearing or use of living things, found himself a party to the "experiment on a gigantic scale," which had been going on ever since the human race withdrew for their own ends plants or animals from the feral and brought them into the domesticated state.

Mr. Darwin with characteristic modesty had probably underrated the effect which the "Origin of Species" would have as an argumentative statement of his views. It probably ultimately seemed to him unnecessary to submit to the labour of methodising the vast accumulations which he had doubtless made for the second and third instalments of the detailed exposition of the evidence which he had promised. As was hinted at the commencement of this article, his attention was rather drawn away from the study of evidence already at the disposal of those who cared to digest and weigh it to the exploration of the field of nature with the new and penetrating instrument of research which he had forged. Something too must be credited to the intense delight which he felt in investigating the phenomena of living things. But he doubtless saw that the work to be done was to show how morphological and physiological complexity found its explanation from the principle of natural selection. This is the idea which is ever dominant. Thus he concludes his work on climbing plants:—"It has often been vaguely asserted that plants are distinguished from animals by not having the powers of movement. It should

rather be said that plants acquire and display this power only when it is of some advantage to them; this being of comparatively rare occurrence, as they are affixed to the ground, and food is brought to them by the air and rain." The diversity of the power of movement in plants naturally engaged his attention, and the last but one of his works—in some respects perhaps the most remarkable of them—was devoted to showing that these could be regarded as derived from a single fundamental property. "All the parts or organs of every plant while they continue to grow . . . are continually circumnutating." Whether this masterly conception of the unity of what has hitherto seemed a chaos of unrelated phenomena will be sustained time alone will show. But no one can doubt the importance of what Mr. Darwin has done in showing that for the future the phenomena of plant movement can and indeed must be studied from a single point of view.

Along another line of work Mr. Darwin occupied himself with showing what aid could be given by the principle of natural selection in explaining the extraordinary variety of detail in plant morphology. The fact that cross-fertilisation was an advantage, was the key with which, as indicated in the pages of the "Origin of Species," the bizarre complexities of orchid flowers could be unlocked. The detailed facts were set out in a well-known work, and the principle is now generally accepted with regard to flowers generally. The work on insectivorous plants gave the results of an exploration similar in its object and bringing under one common physiological point of view a variety of the most diverse and most remarkable modifications of leaf-form.

In the beginning of this article the attempt has already been made to do justice to the mark Mr. Darwin has left on the modern study of geographical botany (and that implies a corresponding influence on physio-palæontology). To measure the influence which he has had on any other branches of botany, it is sufficient to quote again from the "Origin of Species":—"The structure of each part of each species, for whatever purpose used, will be the sum of the many inherited changes, through which that species has passed during its successive adaptations to changed habits and conditions of life." These words may almost be said to be the key-note of Sachs's well-known text-book, which is regarded as the most authoritative modern exposition of the facts and principles of plant-structure and function. And there is probably not a botanical class-room or work-room in the civilised world, where they are not the animating principle of both instruction and research.

Notwithstanding the extent and variety of his botanical work, Mr. Darwin always disclaimed any right to be regarded as a botanist. He turned his attention to plants doubtless because they were convenient objects for studying organic phenomena in their least complicated forms; and this point of view, which if one may use the expression without disrespect, had something of the amateur about it, was in itself of the greatest importance. For, from not being, till he took up any point, familiar with the literature bearing on it, his mind was absolutely free from any prepossession. He was never afraid of his facts or of framing any hypothesis, however startling, which seemed to explain them. However much weight he attributed to inheritance as a factor in organic pheno-

mena, tradition went for nothing in studying them. In any one else such an attitude would have produced much work that was crude and rash. But Mr. Darwin—if one may venture on language which will strike no one who had conversed with him as overstrained—seemed by gentle persuasion to have penetrated the reserve of nature which baffles smaller men. In other words, his long experience had given him a kind of instinctive insight into the method of attack of any biological problem, however unfamiliar to him, and he rigidly controlled the fertility of his mind in hypothetical explanations by the no less fertility of ingeniously-devised experiment. Whatever he touched he was sure to draw from it something that it had never before yielded, and he was wholly free from that familiarity which comes to the professed student in every branch of science, and blinds the mental eye to the significance of things which are overlooked because always in view.

The simplicity of Mr. Darwin's character pervaded his whole method of work. Alphonse de Candolle visited him in 1880 and felt the impression of this. "He was not one of those who would construct a palace to lodge a laboratory. I sought out the greenhouse in which so many admirable experiments had been made on hybrids. It contained nothing but a vine." There was no affectation in this. Mr. Darwin provided himself with every resource which the methods of the day or the mechanical ingenuity of his sons could supply, and when it had served its purpose it was discarded. Nor had he any prepossession in favour of one kind of scientific work more than another. His scientific temperament was thoroughly catholic and sympathetic to anything which was not a mere regreeding of old scientific dry bones. He would show his visitors an *Epipactis* which for years came up in the middle of a gravel walk with almost as much interest as some new point which he had made out on a piece of work actually in hand. And though he had long abandoned any active interest in systematic work, only a few months before his death he had arranged to provide funds for the preparation of the new edition of Steudel's Nomenclator, which, at his earnest wish, has been projected at Kew.

(To be continued.)

MASCART AND JOUBERT'S "ELECTRICITY AND MAGNETISM"

Leçons sur l'Électricité et la Magnétisme. Par E. Mascart et J. Joubert. Tome I. (Paris, 1882.)

MANY of our readers must already be familiar with the "Électricité Statique" of M. Mascart. They will therefore turn with high expectations to the perusal of the "Leçons sur l'Électricité et le Magnétisme," of which he is one of the authors. On the whole they will not be disappointed. They will find in it all the limpid clearness, all the vivacity, all the elegance of presentation, both spiritual and material, that characterise the best French text books; and they will find withal none of the shallowness with which their grudging admirers have been wont to credit them. It is a wonderful national gift that our Gallic neighbours have—their power of scientific exposition. We Britons, with a stray exception, are far behind them; still farther are our German cousins. Notwithstanding our undoubted kinship in language and

descent with the Germans, and all our well-founded appreciation of their excellence, we weary of their very virtues. One turns from their copious *Gründlichkeit*, as from the indispensable *labour* of life, and one finds in the reading of a good French text-book a never-failing pleasure.

Only the first volume of the *Leçons* is as yet before us, and some of our criticisms may have, on that account, to be taken with allowance; for the head, however important, is not the whole body. We see at once that there is little in common between them and the "*Électricité Statique*;" the plan of the work, so far as it has gone, is quite different. It originated, so the preface tells us, in the lectures of one of the authors at the *Collège de France*. The first volume is general and theoretical; the second is to be special and practical. As to the propriety of such an arrangement, much depends on the class of students to which it is addressed. If it is meant for such as have already a considerable knowledge of electrical phenomena, and some practice in accurately conceiving and describing them, then the plan is good. If, on the other hand, the reader is supposed to be a beginner in electrical science, knowing nothing of the phenomena, but furnished merely with the requisite mathematical knowledge, then we do not think well of it. We prefer in that case, the arrangement of the "*Electricité Statique*," that is, a fuller account of the phenomena upon which the fundamental principles rest, with a mathematical treatment sufficient to prevent vagueness of impression, and thereafter a detailed deductive account of the consequences of the fundamental principles, and a full description of the phenomena irrespective of their agreement or disagreement with theory. Assuming that we have to deal with a student, who has the first element of a physicist, viz. a tolerable mathematical education, perhaps the greatest danger to be avoided is formalism, or blind swearing, *in verba magistri*. Nothing is more likely to encourage this, than hurried and hasty discussion of fundamental facts. Nothing in reality is gained by driving the learner express to the law of the inverse square, and then leisurely expounding its consequences. Far better, that we should first secure for him a thorough qualitative understanding of the natural phenomena; and then teach him how they can be built together upon an abstract frame-work, whose lines they will follow, not necessarily with absolute coincidence. The learner must be taught at the very outset that analysis is the servant and not the master of the physicist; and that a physical idea is not always simplified by clothing it in an analytical suit of buckram. This much as a warning to possible students of this volume.

With one feature of the plan of these *Leçons* we must express unqualified satisfaction; that is the adoption of the methods of Thomson and Maxwell. At times these are so closely followed that the paragraphs are little more than translation; at other times considerable changes, chiefly in the way of simplification, are introduced. At the same time, the authors have not scrupled to borrow from other sources, where good material was to be had. They have gone on the principle of Molière, "*je prends mon bien où je le trouve*"; and rightly, for scientific light (unlike political or theological), is not supposed to be the property of one sect or one country. The English reader

will not find much that is new, or perhaps we should say not accessible to him in his own language, however much he may learn as to arrangement and demonstration. Originality apparently is not aimed at; the authors put before their readers such of the modern development of electrical theory as they deem most important in themselves, or most likely to be useful to the physicist. We are of opinion that their selection on the whole has been judicious; and therein lies the chief merit of the book. It will, therefore, fill a great gap in French scientific literature. Possibly the second volume may help to fill the corresponding gap in the experimental part of the subject, which exists, unfortunately, in English as much as in French literature.¹ How urgently such treatises are wanted, and how ignorant one nation may be of what is common-place to another, is well exemplified by the fact that a distinguished *savant* like Prof. Clausius lately published, both in *Wiedemann's Annalen* and in the *Philosophical Magazine*, as something new and noteworthy, the theorem of mutual potential energy and certain consequences therefrom, that have been familiar to us ever since we knew anything of electrical theory, *i.e.* some ten years or more.²

We are thus led to notice the one serious defect of this treatise—the entire want of all references to original sources of information. These *Leçons* can have been meant only for those that contemplate a special study of electricity or original work of some kind bearing upon it; for such learners knowledge at first hand in some degree is essential; and who is to lead the scientific sheep to the water-springs if their responsible shepherds do not? We are well aware, from bitter experience, of the drudgery involved in this part of book-making, and of the difficulty, with all care, of being absolutely accurate and just; but utter neglect of the duty is inexcusable. Here is a provoking instance. The reader is aware that there are two different ways of representing the action of a mass of polarised molecules:—First, by a volume and a surface-distribution of attracting centres; second, by a surface distribution alone. The first of these is undoubtedly due to Poisson. The second is continually used in German books, and attributed to Gauss (the first method, and Poisson with it, they mostly ignore). Now MM. Mascart and Joubert add to the diversity by quoting the second method as Poisson's. It is certainly news to be told that Poisson knew of any such general theorem, and a cursory re-examination of his memoirs failed to find it. Until the exact reference is given, we must hold our previous conviction that the theorem in question was virtually first given by Green in his essay on "*Electricity and Magnetism*" (Nottingham, 1828). It was discovered independently by Gauss, whose statement of it (the first explicit one) is given in Art. 2, "*Intensitas Vis Magneticae, &c.*," read December, 1832, to the Royal Society of Göttingen. His demonstration is given in Art. 36 of the "*Allgemeine Lehrsätze, &c.*" Again, the corollaries from Gauss' Theorem of Mutual Potential Energy in Art.

¹ The Germans have the admirable treatise of Wiedemann, which, in its forthcoming shape, with electrostatics added, will be the greatest experimental treatise on electricity in existence.

² The theorem is simply a particular discrete form of Green's theorem; and in this shape was originally given by Gauss in his "*Allgemeine Lehrsätze, &c.*" In one point of view it is simply a property of homogeneous functions of the second degree, and plays a part in many branches of mathematics, *e.g.* curves and surfaces of the second degree, theoretical dynamics, strains and stresses, &c.

63 may have been originally drawn by M. Bertrand ; but, as no reference is given, we cannot meantime be sure whether his claim is any better than that of Clausius.

Detailed analysis being clearly out of place here, we conclude with a few running comments on the different parts of the work. The first part deals with Electrostatic Phenomena. Except that we think the introductory chapter somewhat hurried and meagre, we commend the general simplicity of the arrangement. A quasi-physical proof of most of the general propositions concerning electrified systems is given, and, we think, in the interest of the physical reader, that this is right. The seventh chapter of this part is especially recommended to the notice of our readers ; there, so far as we know for the first time, Sir W. Thomson's theory of dielectrics finds its place in a text-book on Electrostatics ; both here and in the corresponding chapters on Magnetism the authors show a complete appreciation and mastery of this important step in mathematical physics. Until Maxwell's treatise was written, this piece of Thomson's work had been apparently forgotten. It has lately been taken up in Germany, more especially by Helmholtz *more suo*. This neglect is no doubt to be explained by the equal neglect of the ideas of Faraday, of which Thomson's theory is the mathematical embodiment. The errors one occasionally finds on this subject in continental text-books of authority are very surprising, e.g. it will be found stated that a small sphere of magnetic or diamagnetic substance tends to move *along the lines of force*; the better diffusion of the true theory will surely tend to prevent such fundamental mistakes as this. The application of Thomson's theory to dielectrics is most interesting and important theoretically ; but great difficulty has been found in verifying it experimentally, owing to the scarcity of bodies that will insulate sufficiently well. Its application to magnetics has been most successful, as our readers doubtless know.

The second part treats of electric currents, stationary and variable, and will probably be found well suited for the higher class of practical electricians ; the account of the theory of telegraphic signalling deserves special mention. In Chapter II. of this part the authors are more cautious as to Volta's law of contact than they are at the end of the former part, knowing doubtless, as sound practitioners, that they are on delicate ground.

The theory of magnetism, which constitutes the third part, suffers, as did the electrostatics, in the beginning, from the suppression of experimental detail. We cannot reconcile ourselves to the definition given of the magnetic axis as the line joining the poles of the magnet. This seems a very artificial and difficult way of introducing this fundamental conception ; and we do not see the advantage over the ordinary method, which defines it as that direction which is always found parallel to a certain fixed vertical plane when the magnet is suspended freely under the earth's action alone at a given time and place. We also fail to see why, in mentioning the hypotheses advanced to explain terrestrial magnetism, Gilbert and Biot should be mentioned, and Halley and Hansteen forgotten. In other respects, this part of the work gives as good an account of its subject as most treatises we have seen. Our readers may note the discussion of the direct mag-

netic action of the heavenly bodies as something fresh in a text-book.

The last part of the work deals with Electro-magnetism. The connection between a current and the equivalent magnetic shell is deduced in a very ingenious (although we scarcely think simple) way from the law of Biot and Savart. The other method, which we prefer, is also given, in which the elementary proposition is that a plane circuit, whose linear dimensions are infinitely small compared with the distance of the point at which its action is considered may be replaced by a small magnet. A separate chapter is very properly given to the Methods of Ampère, and the authors have shown their judgment in refraining from loading their pages with the various solutions of the indeterminate problem to find the elementary law of electrodynamic action of which we have lately had a superfluity. An excellent account is given of the general theory of Maxwell. The only thing we would take objection to is yet another meaning given to that overburdened word Electromotive Force; the authors use *Force Electromotrice Totale* in place of Maxwell's *Vector Potential*. The deduction of the rotation of the plane of polarisation from Hall's phenomenon is given ; but Prof. Rowland's name is not mentioned in connection with it ; although we are under the impression that it was first given by him in the *American Journal of Mathematics*.

In a supplementary chapter some examples are given of the application to electrical phenomena of the principles of Carnot. Certain of these, due to M. Lippmann, are ranged under the somewhat high-sounding title of the Conservation of Electricity. We are a little inclined to question the propriety of this phrase ; but we are certainly obliged to MM. Mascart and Joubert for a succinct account of what we are to understand by it.

We shall look with much interest for the second volume of this work, in which, among other things of interest to practical electricians, we are promised a discussion of the efficiency of electric generators and electromotors, a subject on which the recent experience of the authors at the Paris Exhibition must have well qualified them to give an opinion.

G. C.

OUR BOOK SHELF

Die Gasteropoden der Meeres-ablagerungen der ersten und zweiten miocänen mediterran-slufe in der Oesterreichisch-Ungarischen Monarchie. Von R. Hörnes und M. Auinger. Lieferung 1, 2, 3. (Vienna: Hölder, 1879-1882.)

A MERITORIOUS and useful contribution to our knowledge of the tertiary of middle Europe. The first-named author is the worthy son of a worthy sire, the late Prof. Hörnes, whose work on the fossil shells of the Vienna Basin is so familiar to palæontologists. The total number of species hitherto described or noticed in the present publication is 220, including 94 new species or forms. Out of all this number 11 only are given as recent or living ; and two more may be added (*viz.* *Nassa semistriata* and *Columbella corrugata* of Brocchi), which inhabit the Mediterranean as well as the North Atlantic. These recent species have survived from the Miocene epoch—a period of incalculably remote antiquity—without the slightest change. The rest may be regarded as the *οἱ πλείους* in the same sense as we use euphemistically for our dead. Perhaps some more fossil species may be hereafter iden-

tified with living species when palæontologists work in union with naturalists, or when conchologists become acquainted with both kinds of species. This is a great desideratum; and for want of it several eminent palæontologists (Nyst, Hörnes, and others) made regrettable mistakes in such identification, having been misled by names and not things. We may observe that Gastropoden, instead of Gasteropoden, is the more correct and usual spelling of the word. The plates, sixteen altogether, are admirably executed; and the publication does great credit to the Imperial Institute of Geology at Vienna.

J. GWYN JEFFREYS

LETTERS TO THE EDITOR

[The Editor does not hold himself responsible for opinions expressed by his correspondents. Neither can he undertake to return, or to correspond with the writers of, rejected manuscripts. No notice is taken of anonymous communications.]

[The Editor urgently requests correspondents to keep their letters as short as possible. The pressure on his space is so great that it is impossible otherwise to ensure the appearance even of communications containing interesting and novel facts.]

The Winter of 1881-82

YOU have given some figures about the winter of 1881-82 in Great Britain. It was relatively much warmer here. The mean temperatures and its variation from average for November, 1881, to April, 1882, was:

	Nov.	Dec.	Jan.	Feb.	March.	April.
Mean	32°·0	23°·2	29°·5	25°·0	31°·5	38°·2
Diff. from average	+2°·7	+3°·1	+14°·5	+8°·4	+8°·0	+3°·1

The general character of the three months is thus a very decided high temperature. That of January was the warmest on record in the 130 years' observation. If we take the mean of the three months, January, February, and March, it is also the highest on record, viz., 28°·7; the other years in which these three months had the highest temperature were: 1822, 28°·1; 1863, 27°·4; 1843, 26°·9; 1794, 26°·6. The temperature of the five months, November to March, viz., 28°·2 in 1881-82, was surpassed only once, in 1821-22, 29°·3; the other years when these months were warmest are: 1842-43, 27°·6; 1761-69, 27°·1; and 1826-27, 26°·9.

The Neva was frozen less than four months, while on the average the ice lasts nearly five months (147 days), and in the winter of 1880-81 the river was frozen 184 days, the longest time on record since the observations began, that is, for about 175 years. The date of opening of the river this year, March 30, is the earliest, except that of 1822 (March 18).

The last winter is, besides, noticeable for its deficiency of snow, there being scarcely ten days of fair sleighing. The precipitation of the months from November to March was 1°·9 less than the average, that of December alone by 0°·8, that is, by nearly two-thirds. Besides, a large part of it fell as rain. On account of the want of snow, the rivers had not their ordinary spring floods, and great quantities of timber, prepared to be floated for the use of St. Petersburg, could not be moved.

On the middle and lower Wolga, the snowfall of last winter was excessive, and even Taschkent and the valley of Ferghana, in Central Asia (lat. 40°-42°), had an exceedingly cold winter, with permanent and deep snow. The winter was also very cold in Transcaucasia, the minimum temperature in November, 1881, being lower than ever observed before in Tiflis.

St. Petersburg, May 27

A. WOEIFOF

The Mean Temperature of the Atmosphere at the Surface of the Earth as Determined by Observations and by Theory

WHEN several people, not knowing each other, arrive at the same results, the one by compilation and computation of observations, the others by theory, these results present a good probability of correctness, and the theory involved ought to be of interest to science.

In NATURE, vol. xxv. p. 395, I read—"The temperature of the southern hemisphere has lately been investigated by Dr. Hann with the aid of recent observations of temperature in high

southern latitudes, especially those made during the Venus transit in 1874. For mean temperature of the whole atmosphere he obtains 15°·4 C., and as that of the northern hemisphere was estimated by Ferrel to be 15°·3 C., it is very probable that both hemispheres have the same mean temperature. Dr. Hann, however, also shows that between 40° and 45° south latitude, the southern hemisphere becomes warmer than the northern in the same latitude, and that a difference between the two persists at least to the confines of the hypothetical antarctic continent. . . ."

In "On some Properties of the Earth," 1880 (Wertheimer and Lea, publ.) occur the following passages, founded on and connected by theory alone (p. 95):—"We thus find the average temperature of the atmosphere at the surface of the earth to be 20° C., the isotherms of 20° C. having in their mean the parallels of 30° for basis; this figure, obtained by reasoning, is confirmed by isothermal maps. We will see why the 20° are lowered to 15°·22 C., the true mean temperature of the atmosphere at the surface of the earth."

And on pp. 123 to 126: "The line of greatest heat is in the mean moved $\frac{1}{29\cdot78} + \frac{1}{175}$ of the sphere, or 3° 58' + 4' latitude, north of the equator. Temperature is therefore in a compressed or higher state in the lower latitudes of the north." . . .

"Inside the isotherms with the parallels 38° 58' as basis, the temperature of the north is in excess over that of the south. This isotherm of the mean atmospheric temperature reaches over sea so far north as to embrace those seas which may be called the Mediterranean . . . it reaches on land to 47° 50'-3° 56', where the temperature of Genoa in 43° 51' N. lat. is 15°·7 C., and that of Alais 44° 10' N. lat. is 15°·4 C. Beyond this isotherm, or beyond the bases of 38° 58' lat., the difference between north and south decreases [which implies that the temperature at the south gets gradually warmer than at the north, chiefly in longitudes examined by Dr. Hann]. . . . At the isotherms of 1°·666 C., of which that at the south is quite maritime, and almost without curving, the equilibrium of temperature between south and north is re-established, the isotherms coincide, each in its mean, in both hemispheres, with their parallels or bases, they divide the hemispheres in proportion 1 : 4·78 . . ."

O. REICHENBACH

Sea-shore Alluvion—the "Chesil"

GREATER attention and speculation have been bestowed on this than any other of our marine littoral moles, the Transactions of various societies abounding in papers describing it, and as the westernmost of our south coast beaches, within the limits of the narrow seas, may well terminate a review thereof.

Leland, Camden, Lambarde, and Holinshed, all describe it, and how it fluctuates in quantity dependent on the wind. Leland used the word "Chesil" (which became a proper name as applied to this particular bank) as a general term, descriptive of shingle banks, throughout his work. Lilly, who wrote in 1715, describes it most accurately. Hutchins calls it "Steepstone," and derives its name from "Ceorl," the Saxon for gravel. Gough adopts the same derivation, calling it "a prodigious heap of pebbles thrown up by the sea, beginning at Chesilton, in Portland, and reaching beyond Swyre, 16½ miles."

The most remarkable feature is the top "full" about fifteen feet above the lower ones at the Portland end forming a huge seaward wall or mole, exceeding anything of the kind to be seen along our coasts, the land-slope of which is flat. At the east end it is thirty to forty feet above high water of springs, gradually lowering westward, and the stones decreasing in size. The land-locked tidal lake, the "Fleet," between it and the main, is another feature so common to these formations; it terminates opposite the valley to Abbotsbury, down which runs a small mill-stream. Between Lord Ilchester's castle and the Abbotsbury Coastguard Station the great beach ceases, the bight terminating in low tertiary cliffs, which intercept the top "full," the lower "fulls" continuing of an average height, as at Deal and elsewhere; two to three miles west of Abbotsbury the beach is thrown up into very sharp slopes, which, from the fineness of the material, become very solid, and continues to decrease in size and altitude, intercepted by the cliffs at Burton, and again formed into a moderate "full" on each side of Bridport harbour. The great elevation attained by the eastern end of this bank, where it abuts against the Island of Portland, exhibits an exceptional accumulation of water-driven material in the hollow of, and to the north-east of the Great West Bay,

which bears, with seamen, the ugly name of "Dead Man's Bay," from an embayed vessel caught in a south-west gale seldom escaping shipwreck. More than half a century back, Fleet was inundated from a breach in the beach, and the church washed down, and many houses in Chesilton destroyed.

It is said locally, that the material is so finely graduated, that a native boatman or fisherman can tell in the darkest night the exact locality his boat may come ashore or be beached on, by picking up a handful of the gravel. In a south-west gale it is next to impossible to stand on the eastern crest, from the rain of pebbles projected over its summit by the breaking waves.

The Chesil is shown with great accuracy in early manuscript maps, especially in a remarkable series of drawings collected by the great Cecil, well known at the British Museum as "Lord Burleigh's Book;" also in drawings by Collins and Lilly. From these it would appear, that two or three centuries back the "Fleet" was wider, leading to the inference that the beach had retreated landward; but a close inspection of the bank does not support this conclusion, but appears to show that the surplus material is driven in heavy weather right over the crest sloping towards the "Fleet," the area of which has been narrowed and reduced by this continued process.

The gradation of material here again shows the ultimate leeward movement from west to east, due to preponderance of winds from the first quarter; the altitude from three to four times that of the normal elevation of ordinary English beaches above high water; also the upper plateau above the usual neap and spring "fulls" are striking features, showing its abnormal character.

The largest shingle travelling to leeward and to the summit, is illustrative of the accumulative energy of the heavier projectiles, and their being less acted on by the recoil than the smaller materials.

It may be well to notice here the soundings taken in H.M.S. *Beagle*, between Santa Cruz and the Falkland Islands, referred to by the late Mr. Darwin in his work "Geological Observations," published in 1876, and which he truly describes as presenting the usual phenomena in such cases. The material quickly and regularly decreasing in size with increased depth and distance from shore, under two miles out large and small pebbles were found intermixed.

Miles.	Depth, fathoms.	Pebbles size of walnuts and smaller.
At 2 to 4 ...	11 to 12 ...	Do. size of hazel nuts.
4 to 7 ...	17 to 19 ...	$\frac{3}{8}$ " to $\frac{1}{2}$ " diameter.
10 to 11 ...	23 to 25 ...	$\frac{1}{8}$ " diameter.
12 ...	30 to 40 ...	$\frac{1}{16}$ " do. to fine sand.
22 to 150 ...	45 to 65 ...	

This is confirmatory of, or supported by, observations around our own coasts. J. B. REDMAN
6, Queen Anne's Gate, Westminster, S.W., June 10

Meteor

ON Wednesday, June 7, 9.45 p.m. G.M.T., at a station 396 yards north-west by west of the transit-circle of the observatory, Mr. W. H. Robinson's attention was attracted by the sudden appearance of a fine meteor about 3° below Mars, which passed through a point 5° below Regulus, and, continuing its course about 12° further, finally disappeared. Almost instantly after being first seen, it shone very brightly, then assumed a train of detached luminous beads, and towards the end of its path burst, presenting an appearance similar to the bursting of a rocket. Its greatest brilliancy was equal to Venus. The length of the whole track was about 25°, and the time of visibility of the train was about five seconds. E. J. STONE

Radcliffe Observatory, Oxford, June 8

Earthquakes in Naples

THE seismographs of the Vesuvian Observatory and of the Naples University have shown increased activity the last two days. This culminated this morning at 6.47 a.m. in a distinct shock seven seconds duration, direction north to south, chiefly undulatory, but elevatory towards the end. From these facts Prof. Palmieri considered it to come from a distance, and not of local origin. This was proved by telegrams from Isernia and Vinchiatiuro in the Apennines. All to-day the amount of vapour from Vesuvius is much more abundant, and this evening it is

brilliant; the quantity of lava flowing is increased. This is a good example on a small scale of seismic activity having its focus in a mountain chain affecting the neighbouring volcanoes. Naples, June 6 H. J. JOHNSTON-LAVIS

THE "POLYPHEMUS"

HER MAJESTY'S ship *Polyphemus*, which has been five years under construction, is now being prepared for her final trials. She contains so many peculiarities of design and novelties of various kinds in her machinery and fittings that much scientific interest attaches to her performances. Her form is different from that of any other ship ever built. The part above water has been described as resembling a cylinder floating on its side and deeply immersed, which is tapered at the ends to form a bow and stern. An idea of her appearance above water may be obtained by imagining such a cylinder to be flattened over a large portion of its area to form a deck, and to float at a height of 4 feet 6 inches out of water. The whole of the exposed part of this surface, which has great curvature near the water line, and enters the water at an angle of about 45 degrees, is plated over with steel armour, which is carried some distance below water. The curvature of the sides is continued to a depth of several feet below the water line, and from this point they turn sharply in and converge towards each other at the keel almost in straight lines. A cross section of the vessel is similar to a pegtop, which is floating in water at a depth below its greatest breadth, and the emersed part of which presents a convex surface only. Upon this form of hull an iron superstructure is mounted, which carries a hurricane deck from which the ship is worked, and to which the openings into the main body of the ship are carried up. Two protected coverings are fitted on this deck, one at each end, which are connected with the structure of the hull, and give means of communication with the interior. There are three revolving turrets on each side, which are each armed with one of the heaviest Nordenfelt guns. This superstructure may all be shot away without injuring the vessel or impairing her powers, except as regards the use of the Nordenfelt guns.

The lines of the ship are very fine, and have been determined chiefly with a view to great speed. The armour plating is very light; no heavy guns are carried; many devices have been adopted to reduce the weight of the machinery; and some of the main fighting qualities of most other men-of-war have been sacrificed, in order that a high speed may be realised. The speed she was designed for is 17 knots; although with the great amount of horse-power; for her size, she is intended to indicate, a higher speed might be expected if it is efficiently utilised. The offensive weapons of the *Polyphemus* consist of the ram and torpedo. She will carry no guns except six Nordenfelt machine-guns, which will each be carried in a projecting turret at the height of the flying deck. These will serve to repel boat attack; but for offensive operations against powerful vessels, she will only be able to employ the ram and torpedoes. The successful use of these weapons will depend primarily upon speed. High speed is essential, to prevent failure in ramming; and in using torpedoes under heavy gun-fire, it is very important to be able to approach an enemy quickly, and to get away again with all possible celerity, as the contingencies of this mode of fighting may require. The efficiency of the *Polyphemus* thus being a question of speed, it will be understood why so many sacrifices have been made in order to enhance this quality. The vessel has been constructed as light as possible throughout, and saving of weight has been carried to a great extent.

The hull is built of mild steel; the frames being of Bessemer, and the bottom plating of Landore-Siemens steel. There is a double bottom, and the hold of the ship is largely divided into separate watertight compart

ments by means of bulkheads. A longitudinal bulkhead is fitted at the middle line; the boilers are contained in four separate water-tight compartments; the engines in two; and the coal bunkers are also water-tight.

The engines and boilers are manufactured by Messrs. Humphreys and Co. There are two pairs of engines working twin screws. They are of the horizontal compound type, the cylinders of each pair being 38 inches and 64 inches in diameter, and the stroke 39 inches. They are intended to indicate an aggregate horse power of 5500. These engines are remarkable for their lightness and the comparatively small space they occupy. Most of their novel features have been adopted for the purpose of economising weight and space. They are almost entirely of wrought iron, Whitworth steel, and gun-metal; very little cast iron being used in their construction. The screws are three-bladed, and are 14 feet in diameter, with 15 feet to 17 feet pitch. The shafts are left bare where they come outside the hull of the ship, and are not surrounded by tubes, as is usual in ships of the Navy. These tubes have been dispensed with for the purpose of diminishing the resistance. The boilers are of the locomotive type; and these also were adopted in preference to the ordinary marine boiler, for the purpose of saving weight and space. They are 5 feet 3 inches in diameter, and 14 feet 4 inches in length, and work with a steam pressure of 120 tons per square inch. The shells are of steel, the fire-boxes of iron, and tubes of brass; and they are similar to ordinary locomotive boilers, except that the tubes are shorter and the fire wells less deep. The stoke-holds are closed in, and forced draught is worked with, as in the fast torpedo boats. This is supplied by four fans, two of which are 4 feet and the other two 3 feet 6 inches in diameter. The fan engines have 9-inch cylinders, and $4\frac{1}{2}$ inches stroke, and run at the rate of 900 to 1000 revolutions per minute when working at full speed.

The trials of the machinery have, so far, not been successful, chiefly on account of difficulties with the boilers. During the first series of trials, on March 2, 4, and 6 last, nothing could be done on account of priming. The greatest speed realised was 10 to 12 knots, when the boilers primed so badly that a stop had to be come to. On March 31 there was another trial, the last down to the present time, when the difficulties of priming were mainly got over. The indicated horse-power on that occasion was about 5000, and the speed a little over 17 knots. The air-pressure in the stoke-holds, which gave the forced draught, was equivalent to 5 inches of water. On this occasion the boiler-tubes leaked very badly, so that the full power could not be realised. The priming was due to oil from the engines getting into the boilers, and this now appears to be remedied. In the torpedo boats that are fitted with locomotive boilers, the same difficulty arises, and oil is not used at all in the cylinders, or only very sparingly. The leaking of the tubes is a more serious difficulty to get over, although in the *Polyphemus* the arrangements appear to admit of improvement. For instance, solid iron stays were fitted in the midst of the brass tubes; and it must be obvious that the unequal rate of expansion of the stays and tubes when heated to a high temperature must have considerably strained the tube plates. These stays are now being removed, and new tubes are being fitted throughout, the ends of which are to be screwed into the tube plates.

This difficulty of leaky tubes is not peculiar to the *Polyphemus*. Messrs. Thornycroft are in the same position with a large number of torpedo boats they have completed for the British Government, and which are undergoing a similar ordeal of testing by the Admiralty engineers. These boilers cannot be got to stand satisfactorily, and a number of experiments have just been carried out at Portsmouth upon tubes fitted in various ways in a torpedo boat boiler, which, it is hoped, will show how the present defects can be remedied. Loco-

motive boilers are not adapted for working continuously at a high rate, and for steaming at full speed over long distances. The strain put upon the boiler, and the work attempted to be got out of it, is too great under these circumstances. What is being done in the *Polyphemus* and in the torpedo boats, is to get the advantage of the lightness of this type of boilers; and only to press them up to their full power for comparatively short times when required in an emergency.

The armour plating is of steel; and here again we find an attempt to combine great defensive power with extreme lightness. It extends over the whole of the above water-portion of the hull, and for a short distance below the water-line. There are first two half-inch thicknesses of Landore-Siemens steel, upon which are placed plates of Whitworth fluid-compressed steel, one inch thick. Outside of this is another layer of hard Whitworth steel, one inch thick, which is tested to a strain of sixty-eight tons per square inch. This outer layer is fitted in small plates or scales ten inches square, secured with coned steel screw bolts, one at the centre of each of the plates, and one at each of the corners. Along the middle of the turtle-back deck these scales are omitted, and the armour is there only 2 inches thick. The bases of the trunks from the hatchways to the flying deck are protected by a glacis of 6-inch steel armour to a height of 3 feet 6 inches above the deck; and the front of the foremost trunk is plated to a height of about 5 feet above the flying deck, with 8 inches of steel-faced armour, which gives protection to the pilot tower.

The armament, as has been stated, merely consists of six Nordenfelt machine-guns, which are each mounted in a revolving turret that projects from the side of the flying deck. The fighting weapons she possesses are the ram and torpedoes. The former is very long and strongly constructed. It is, however, interfered with by a tube for ejecting torpedoes right ahead, which is fixed in the centre of the ram. This seems a doubtful expedient to adopt, and to endanger to some extent both the ram and the torpedo-tube. The bow has been made so as to protect this tube as much as possible. The torpedo armament consists of the tube referred to for ejecting torpedoes right ahead, and of two tubes on each side, also placed under water, in a compartment at the fore side of the boiler-rooms. In this torpedo compartment one tube on each side is fixed right abeam, and the other in the direction of about 20 degrees at the fore side of the beam. There is only means of firing one torpedo end on, the other four tubes being on the broadside. It is questionable as to the merits of this arrangement, considering that the end-on position will be the one for attacking from in the *Polyphemus*, for the purpose of using the ram, and also to enable the greatest possible resistance to be got out of her thin armour. Independent air-compressing machinery for the torpedoes is carried in each of the torpedo-chambers, in which also a number of torpedoes will be carried ready for use.

The height of the hull proper above the water line is, as we have said, 4 feet 6 inches. It is kept low to reduce the chances of penetration; but to furnish more buoyancy than this small freeboard gives, a strange device has been adopted. At the keel of the ship a deep rectangular recess is made in which about 300 tons of iron ballast is carried. This ballast is so fixed that it can be let go at pleasure, and the ship lightened accordingly. The draught and trim may thus be regulated to some extent should the ship be injured in action. If the whole of the ballast is let go it will lighten her about 14 inches.

As manœuvring power is of great importance to such a vessel as the *Polyphemus*, an attempt is made to increase it by means of bow rudders. Two of the rudders, of the balanced form, are placed forward, one on each side of the bow torpedo tube. They can be drawn up into apertures inside the hull when not required for use; and when

working they may be coupled up with the engine working the stern rudder, and all three rudders worked together. The dead wood has been cut away aft to a large extent in order to reduce the resistance to turning.

DOUBLE STARS

SOME stars when looked at in a telescope are seen really to consist of two stars so near together that the naked eye is not able to distinguish them, but sees them as a single star.¹ The knowledge of some of these objects may be presumed to be almost as old as the telescope. In fact Hevel remarked some of them in the middle of the seventeenth century, but no attention was paid to them, as it was thought that they were really far asunder in space, and merely appeared close together in the heavens, because they were nearly in the same visual ray. It thus escaped notice that one star frequently moves round the other, and Lambert, as late as 1761, founded his opinion that those fixed stars that appear near others, were in no physical connection with them, upon this absence of relative motion, because, as he says in his "Cosmologische Briefe," if they do not move round each other, and still gravitate towards each other, they must long ago have collapsed. But a few years after the Rev. John Michell applied the rules of the calculation of probabilities to the stars in the Pleiades, and showed that it was exceedingly improbable that these stars could appear so near together, if their proximity was the result of a random scattering of the stars over the heavens, and he showed that among 40,000 stars, one could expect to find only one pair within twelve seconds of arc of each other, and none nearer. These speculations were, however wholly conjectural, as long as no proper observations were available, and it was therefore to the purpose when the highly merited Jesuit, Christian Mayer, of the observatory at Mannheim, founded by the Elector of Pfalz, commenced to search for, and systematically to observe, double stars. But he met with no support from his contemporaries, and had to defend his opinions in several polemical pamphlets. His instrument, a mural quadrant by Bird, was scarcely sufficient for the purpose, and his opinion, that, "satellites" of the brighter fixed stars were found at a distance of as much as three degrees, was certainly wrong in the instances he adduced, though Mädler has shown that stars as far asunder may possibly be physically connected.² We must, therefore, consider William Herschel to be the first who proved the existence of double stars. This he did by aid of micrometric measures,³ which he originally had made with the view of

¹ Mizar and Alcor, the "test-star," in the great bear, present to the naked eye very much the same appearance as a double star does, when seen in a telescope. Their distance is about a lunar radius. It is sometimes said that distances less than five minutes are not visible to the eye, but when wearing glasses I see ϵ Lyrae, the distance of whose components is less than four minutes, double.

² It was evidently Chr. Mayer's opinion that the smaller star shone in reflected light. The term "double star" had been applied by previous observers, who little dreamt that these stars would become so interesting.

³ It may be as well to explain in a few words the instrument with which such minute quantities are measured. It is called a micrometer, and forms the eyepiece of a large telescope. It is well known that in the focus of the object-glass of a telescope, the image of the object contemplated appears inverted. Now in this focus are stretched two parallel spider lines, at least one of which is moveable by an extremely fine screw. The magnitude of the object or the distance between the two components of the double star are thus measured in revolutions or fractions of a revolution of this screw; for which purpose the head of the screw is divided into hundredths, the tenths of which are estimated by the eye (see Fig. 1). The value in seconds of arc of each revolution of the screw is either ascertained by measuring some known distance or by measuring the length of a revolution in parts of an inch (a very small quantity) and dividing this by the focal length of the object-glass expressed in inches. The value of a revolution is generally found to vary a little with the temperature, as the steel of which the screw is made expands or contracts with the heat, but this is counteracted by changes in the focal length of the object-glass. It is of more importance to examine the irregularities of the screw, the different turns of which might not exactly be of the same size. Even parts of each turn might be slightly different. However modern engineers have carried the making of screws on the lathe to so high a perfection, that there are screws made in which no errors can with certainty be ascertained. It also deserves to be remarked that it is more easy to make a screw accurate the finer it is.—But the screw gives us only the distance of one star from the

finding the parallax of fixed stars, similar observations having previously been attempted by the Rev. Roger Long, of Pembroke College, Cambridge, who, however, had not been very successful.

Herschel commenced micrometric measures in 1776, when he observed θ Orionis. In 1779 he began systematically to search for and measure double stars, and as early as 1782 he laid his first "Catalogue of Double Stars" before the Royal Society. It contained 269 objects, but few of which had been observed by Chr. Mayer. Subsequently he published other catalogues, which, however, contain many stars more than 32" asunder, which are not now considered as double stars proper; but of the latter Herschel discovered between four and five hundred. He measured double stars micrometrically up to 1785, and again for some years after 1790. The measures showed some discrepancies, but it was impossible to decide whether the relative motion of the components—for changed their position some of them evidently had—was rectilinear or otherwise, and whether it in some cases perhaps arose from the proper motion of one star. However, already in 1794 Herschel explained how they must move in curved paths on account of their mutual gravitation, and in 1803 appeared that famous "account of the changes that have happened during the last twenty-five years in the relative situation of double stars," in which he, from actual measures, proved this to be a fact. But Continental astronomers were nevertheless slow to give in to so

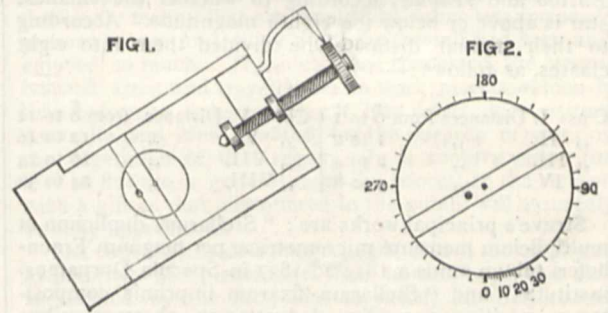

novel and startling a revelation. In France even Lalande openly expressed his want of faith in these disclosures, notwithstanding his high regard for Herschel's merits in other respects.—At the end of his active career Herschel had the pleasure to see his son John Herschel take up this subject with fervour. South, the friend of this illustrious astronomer, joined him in this work, and obtained thus a place in the scientific world, to which his own merits, only for this connection would scarcely have entitled him. J. Herschel went in 1834 to the Cape of Good Hope, where he discovered and made some measures of above two thousand double stars on the southern sky with his 20-feet reflecting telescope. He continued to take an active interest in these stars till his death in 1871, when he left behind unfinished manuscripts that showed that he had been engaged on a general catalogue of double stars and the observations made of them. It contained about 10,000 entries.

Meantime Struve in Russia had commenced a series of double-star measures, which is even now unsurpassed, as well with regard to extent as to consistency. In 1824 he received a 10-inch refractor, mounted equatorially, from Fraunhofer of Munich, and with this magnificent instru-

ment. We require to know also in what direction it is situated. For this purpose the plate on which the micrometric screw and the wires are fixed can be revolved, and the wires placed parallel to the line joining the centres of the two stars. The angle is read off on a circle in firm connection with the tube. This, the so-called angle of position is counted from the line connecting the principal star with the pole. From north 0° round through east 90°, south 180°, and west 270° (see Fig. 2). This circle is adjusted by allowing the stars in their daily motion to run from east to west along the wires. The index should then point to 00° or 270°. But it must be kept in view that the images are inverted, so that e.g. when looking southwards, north appears down.

ment he worked indefatigably for thirteen years, making above 10,000 measures; and it may be said that by this telescope the genius of its maker carried the palm on behalf of refractors in measuring minute quantities in the sky, while the reflectors stepped into the background, and were subsequently preferred only in cases where the definition is of less consequence than light-grasping power.¹ Struve not only made measures—thanks to Fraunhofer's excellent micrometer and his skill in handling it—more accurate than had been possible up to that time, but he also catalogued about 3000 double stars between the pole and fifteen degrees southern declination. He had their places exactly determined with Ertel's meridian-circle, and these observations, compared with those of later date, have in many cases established the fact that the proper motion was common for two stars, that revolved so slowly that no change in their relative position had been discovered by aid of the micrometer. Thus their physical connection is then established, but indeed "optical double stars" are so uncommon within the limits here considered, that the discovery of an optical couple is almost a greater curiosity. In such a case the micrometric measures serve to accurately fix the amount of the proper motion of one star, the other being generally so distant that it appears stationary, as well as to ascertain the parallax of the nearer star if perceptible. Struve also every night carefully noted the magnitude and colour of the stars he observed, and divided them into *Lucida* and *reliqua*, according to whether the smallest star is above or below the eighth magnitude. According to their mutual distance, he divided them into eight classes, as follows:—

Class I. Distances from 0 to 1	Class V. Distances from 8 to 12
„ II. „ 1 to 2	„ VI. „ 12 to 16
„ III. „ 2 to 4	„ VII. „ 16 to 24
„ IV. „ 4 to 8	„ VIII. „ 24 to 32

Struve's principal works are: "Stellarum duplicium et multiplicium mensuræ micrometricæ per magnum Fraunhoferi tubum annis a 1824 ad 1837 in Specula Dorpatensi institutæ," and "Stellarum fixarum imprimis compositarum positiones mediæ deductæ ex observationibus meridianis a 1822 ad 1843 in Specula Dorpatensi institutis."

Though Struve achieved his main results after the arrival of Fraunhofer's refractor, he had made double-star observations as early as 1814, but his apparatus were then so deficient, that he had to try to make use of differences of right ascension observed with a small transit instrument, an attempt that, in spite of his experience as an observer, could not but prove a failure. His observations were subsequently continued, under his direction, by his son, who, with the 14½-inch refractor at Pulkowa, discovered about 500 additional objects. He has made about 7000 measures during the last forty years, and thus we are in possession of observations continued during about seventy years by the Struves, after the same methods.

Meantime, similar investigations had made considerable progress elsewhere. In England, the subject was taken up by the Rev. W. R. Dawes, who, taking into consideration the smallness of his means, achieved more than any contemporary observer. He is justly considered one of the most distinguished of those amateur astronomers, to whom British science is so much indebted. He made about 2000 measures in all. Subsequently, Baron Dembowski, in Italy, commenced micrometric observations of double stars, and though the means originally at

his disposal would have been wholly inadequate in other hands, the accuracy of his measures was about as great as that attained at more richly-furnished observatories. Pushed on by his success, he acquired larger and better instruments from Fraunhofer's successor at Munich, and entered upon a series of observations, in which he greatly surpassed the accuracy of other observers. It is therefore to be regretted that the mass of observations he accumulated during a quarter of a century, has not yet been more than partly laid before the public. Investigators were, however, expecting a volume that would completely embody Dembowski's work, when the mournful news of his death in January, 1881, spread over Europe. Compared to his observations, those made by Sir W. Herschel appear to be as rude as observations made before the invention of the telescope, compared to those of the nineteenth century.

It was in the course of the researches carried on by the latter observers, that circumstances came to light which have proved to be of the utmost importance. I allude to the existence of systematic errors. Already Struve found that he measured angles of position differently, when he inclined his head to either side, and he found that in any case, his distances were different from those given by other observers. He did not, however, follow up this remark, but merely kept his head straight while observing, and with regard to the distances he did not see how his own results could deviate from the truth; but his son, though he is in possession of such a great refractor, has been found to measure double stars altogether erroneously. This he has remedied by observing artificial double stars (white ivory disks on a black ground), and after applying the corrections thus ascertained to his measures on the sky, the accuracy of his results has been sensibly increased, though of course the circumstances attendant on such operations are very different from those under which astronomical observations are made during the night, *e.g.* the artificial double stars are always seen near the horizon and are stationary, while the stars are ever moving, and have to be followed by aid of a more or less deficient clockwork driving the telescope. Dawes also, found systematic errors in his measures. He tried to do away with them by slightly inclining his head when the stars were nearly in a vertical, and by the use of a prism, fixed before the eyepiece, to make them appear vertical, when the line joining their centres formed a great angle with the vertical. He says, in the introduction to his observations, that no one about to draw a straight line with a ruler would lay this crooked on the table; one prefers to lay it parallel to the line joining the two eyes. It is in fact most agreeable to measure a double star when the components are either nearly vertical or nearly horizontal. Dembowski's observations seem free from systematic errors, but with praiseworthy diligence he has thought fit to subject this circumstance to a minute scrutiny. To this end he was observing circumpolar double stars of different classes in every hour angle round the pole, as these errors have been found to depend upon not only the angle the line joining the stars makes with the line joining the eyes of the observer, but also on their mutual distance, and as the error diminishes quickly as this increases, it is recommended to use always the highest magnifying power which the state of the atmosphere and the quality of the object-glass will allow.

Space would not allow me to refer to all the astronomers, who at one time or another have paid attention to the subject, or to discuss the relative value of their work. Father Secchi made some good measures in Italy, Duner, in Sweden, has published about 3000 valuable observations, and Gledhill, in Halifax, has also successfully taken up this work. In spite of the skies of Connaught, that clear so seldom and so irregularly, I have tried to do my best, but I have not succeeded in getting

¹ The definition of an image seen in a large reflector is inferior to that in a smaller refractor, both on account of the greater influence of any defect in grinding the surface of a mirror, and because, when the aperture is larger, the rays of light from the object have to pass through so much larger a portion of the atmosphere, the irregularities and motions in which render the image unsteady and badly defined.

more than 1000 observations up to this. Latterly, this branch of science has made distinct advances in America, where Burnham has made excellent use of the gigantic refractors, which are made by Alvan Clark of Boston. He has discovered a number of important double stars, the components of which cannot be separated at all in older telescopes.¹

In 1878 the French astronomer Flammarion, who is so favourably known from his excellent popular treatises, published his "Catalogue des Étoiles doubles et multiples en Mouvement relatif certain, comprenant toutes les Observations faites sur chaque couple depuis sa découverte, et les résultats conclus de l'Étude des mouvements," a work that is highly valued by double-star investigators, but private observers will do well in consulting also Messrs. Crossley, Gledhill, and Wilson's "Handbook of double-Stars," with its "Supplement."

As remarked above Herschel found that changes had taken place in several systems of double-stars, and in 1836 Struve was able to give a list of a hundred systems, where the components appeared to revolve; but on account of the difficulty of the measures, it was not easy to decide whether this was owing to actual motion of the star or in some cases to divergences of the observations. But he proved beyond dispute in about half the cases that the companion had revolved, and Mädler, who was one of the most indefatigable double-star observers, as well as the most prominent calculator, raised this number to several hundreds. His work, "Tabula generalis stellarum duplicium indicationem motus gyrorum exhibentium," was published in 1849, and contains 650 entries, but many of these were mere surmises, and have not been corroborated by subsequent research.

If the observations were absolutely free from errors, it would be an easy task to investigate the path of the companion, but in addition to the imperfection of every observed position, we have as explained above to guard against systematic differences between the different observers. In long series of observations of quickly revolving stars, this gives occasion to endless discussion. We draw, for instance, a powerful aid in discerning systematic errors, from Kepler's law, that the areas described by the radius vector are proportional to the intervals of time; but he would be a bold man, who in the present state of our knowledge, would affirm that all binary stars have been proved to revolve according to this law in elliptic orbits, in the focus of which the main star is situated,² or would condemn all observations that could not be made to fit into such a hypothesis. But though this assumption is a mere hypothesis, and may remain so for a long time to come, we have nothing else to guide us. In fact we cannot calculate an orbit at all except by aid of these laws.³

W. DOBERCK

(To be continued.)

¹ The difficulty of separating close double stars renders them fit tests for the performance of a telescope. Some idea of the quality of a telescope may be gained, when it is stated that it is able to separate objects of a certain class, be it *lucida* or *religua*, but withal, it is preferable to try its performance on terrestrial test objects. A third sub-class "delicate" double stars, or those in which the companion is so minute compared to the main star, as to require a high degree of optical power to perceive it, has been added by Sir John Herschel, but it deserves to be remarked that the appearance of such objects depends quite as much upon the state of the atmosphere. The companion of Sirius, for instance, has been repeatedly seen in 4-inch refractors under exceptionally favourable circumstances, though in a great latitude. A large aperture is therefore not always an advantage. The situation of the observatory is of much greater importance. Piazzi Smyth has the merit of having for years insisted upon this point. The Lick Observatory, about to be founded on Mount Hamilton, California, will offer unusual advantages. Mr. Burnham has there already discovered some difficult double stars with a minor telescope.

² Both stars revolve, of course, round their common centre of gravity, but it is easy to see that the *relative* position of the two stars is all the same then as if only one revolved. If the changes in the absolute place of one of the stars were known, we would have the means of computing the relative masses; but this has only been possible in a few cases at most.

³ In case of certain triple stars, whose movements do not fit into Keplerian ellipses, we have to represent the motions by aid of epicycles, just in the same way as Ptolemy represented the motion of the planets in the system named after him.

THE MARIANNE NORTH GALLERY OF PAINTINGS OF "PLANTS AND THEIR HOMES," ROYAL GARDENS, KEW

MANY readers of NATURE are doubtless aware that the large collection of beautiful and instructive pictures of flowers painted in various countries by Miss Marianne North, is now, through the noble generosity of this lady, the property of the nation. The collection is in a handsome building specially erected in Kew Gardens for the purpose, at Miss North's expense, and from designs given by Mr. James Ferguson, F.R.S. Last week the gallery was opened without any ceremony whatever, and henceforward it will be open and free to the public at the same times and hours as the museums and other buildings in the Gardens.

Now that this is an accomplished fact, a few words respecting the history and the principal features of the collection may be useful. Impelled by a love of nature, Miss North has spent many years travelling from country to country, and painting the most striking scenes and objects that came under her observation; and from time to time some of these paintings have been exhibited in London. The more Miss North travelled and painted, the more the desire to travel and paint seems to have grown; the result being a large collection of pictures. Then arose the question, what should be done with them? and happily in this Miss North was influenced by the kindly feeling that she would like other less fortunate persons to see and enjoy what she herself had seen and enjoyed so much. This idea once conceived, the warm-hearted artist and traveller set to work more assiduously than before, in order to carry it into effect, even visiting Australia and New Zealand, for the purpose of painting the vegetation of that region. In a country where the love of flowers is general from the poorest to the richest, such a gift as that now offered to the public will assuredly be fully appreciated.

The collection is designated in the title of the catalogue as paintings of "plants and their homes," and this title is justified by the fact, that in nearly all the pictures, plants have supplied the motive, the other objects represented being accessories. Altogether there are upwards of six hundred pictures, representing vegetation in nearly all temperate and tropical parts of the world except Europe and Africa, unless we regard Teneriffe as belonging to the latter country. A descriptive catalogue, compiled by the writer of this notice, and published at Miss North's expense, contains not only the titles of the pictures, but also short notes concerning the life-history, products, &c., of the plants painted, inserted with the intention of making it as instructive as possible to those who know least of such things. There are representations probably of not less than a thousand species, and these include members of nearly every natural order in the vegetable kingdom. The fruit and other useful plants of the different countries are numerous; and associated with them are many of the most ornamental and most striking wild and cultivated plants. In dealing with trees and shrubs, the artist has usually painted a flower-bearing or fruit-bearing branch, or both, in front, and given the habit of the tree or shrub in a landscape behind. Without being botanical, the paintings of the plants are so thoroughly naturalistic, that a botanist has little difficulty in determining such as are not known to him by sight. In so far as regards its prominent features and peculiar types, the Australian flora is more completely portrayed than any other, about seventy-five pictures being devoted to this region. Miss North visited Queensland, New South Wales, Victoria, Tasmania, South Australia, and West Australia; and from each of these colonies she brought home paintings of a large number of the most striking and characteristic plants. Thus of Eucalyptus there are portraits of E-

amygdalina, calophylla, colossea, cordata, ficifolia, globulus, tetraptera, and several others; of other characteristic Myrtaceæ, the genera *Callistemon*, *Syncarpia*, *Agonis*, *Melaleuca*, *Beaufortia*, and *Leptospermum*; of Leguminosæ, *Acacia*, *Gompholobium*, *Kennedy*, *Clianthus*, *Platylobium*, &c.; of Epacrideæ, *Leucopogon*, *Richea*, *Epacris*, *Lissanthe*, and *Styphelia*; of Proteaceæ, *Banksia*, *Grevillea*, *Xylomelum*, *Telopea*, *Hakea*, *Lambertia*, *Macadamia*, *Petrophila*, &c.; of genera belonging to other natural orders, taking them in the order they occur in the pictures: *Phyllocladus*, *Doryphora*, *Casuarina*, *Pimelea*, *Prostanthera*, *Billardiera*, *Exocarpus*, *Anigozanthus*, *Xanthorrhæa*, *Kingia*, *Cephalotus*, *Cheiranthra*, *Xanthosia*, *Leschenaultia*, *Stylidium*, *Johnsonia*, *Trichinium*, *Isotoma*, *Byblis*, *Actinotus*, *Nuytsia*, *Doryanthes*, *Fusanus*, *Come-spermum*, &c., &c. In conclusion I may state that there is a complete index to the catalogue, so that it is possible to ascertain what plants are figured by reference thereto.

W. BOTTING HEMSLEY

AN ELECTRIC RAILWAY

THE following account of the electric railway of Breuil-en-Auge is taken from an article by M. Gaston Tissandier in our contemporary, *La Nature*. The subject of electric railways, which has recently claimed public attention; and the recent construction on a commercial scale of a practical electric railway in the department of

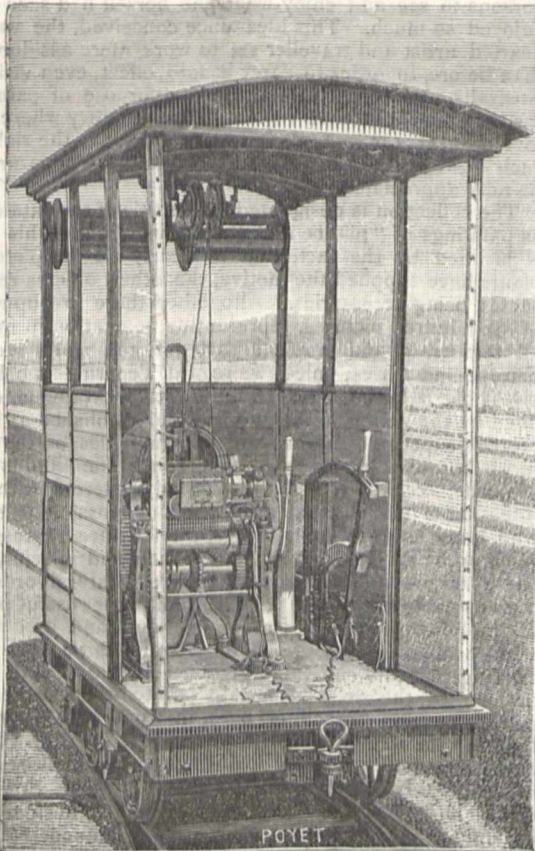

FIG. 1.—The locomotive, with dynamo-electric motor and driving-gear.

Calvados in France derives additional interest from the fact that the motive power is, in this instance, furnished by electric accumulators. We propose to give a general description of the railway, but will first briefly state the object for which the line has been constructed.

The linen-bleaching establishment of M. Paul Duchesne-Fournet is situated at Le Breuil-en-Auge, and is a large concern to which most of the linen fabrics manufactured at Lisieux are sent to be bleached. The complete process of bleaching consists in successively exposing the linen pieces first to the action of chlorine, then to alkaline baths, lastly to the sun's rays. The last operation is of course conducted out of doors by laying out the linen in the open meadows. Each length of linen measures about 100 metres, and the establishment boasts a bleaching ground of 15 hectares (37 acres). The operation of taking up the pieces is laborious, necessitating several workmen.

M. Clovis Dupuy, engineer-in-chief of the works, proposed a mechanical device for picking up the linen pieces by the aid of a railway which carried the requisite

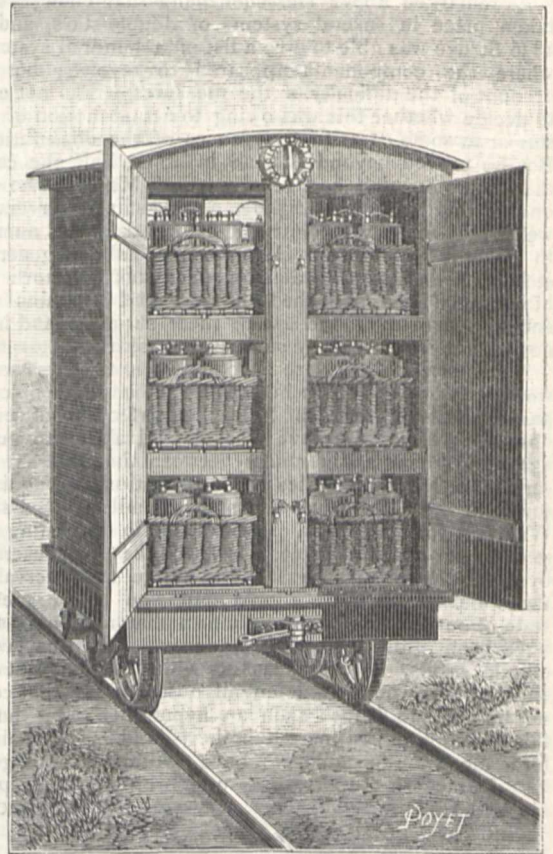

FIG. 2.—The Faure accumulators in the tender.

mechanism. But a railway worked by a steam-engine could not be tolerated in the bleaching field, as the smoke produced by the burning fuel and the ashes projected from the funnel would play havoc with the linen laid out beside the line. M. Dupuy therefore determined to build an electric railway, the construction of which is now finished, and which works very satisfactorily.

The electric railway of Le Breuil-en-Auge passes the end of each of the many plots upon which the linen is laid out, there being a piece of straight line 500 metres in length, and twenty-one branch lines. The total length is 2040 metres. The rails are of the narrow gauge of 0.8 metre (2 feet 7½ inches).

The train is driven by a locomotive shown in Fig. 1, the driving machinery being a Siemens' dynamo-electric machine working as a motor. The currents to drive the motor are supplied from a battery of Faure accumulators

contained in a separate tender, depicted in Fig. 2. The train starts from the factory with the wagons empty. Arrived at the bleach-field, it stops. By the movement of a handle, the motor is thrown into gear with a set of

windlass rollers employed to wind up the linen. Passing between these rollers the linen ascends to another roller in the top of the car, which covers the machinery, where it passes to a workmen, who packs it in folds in a little

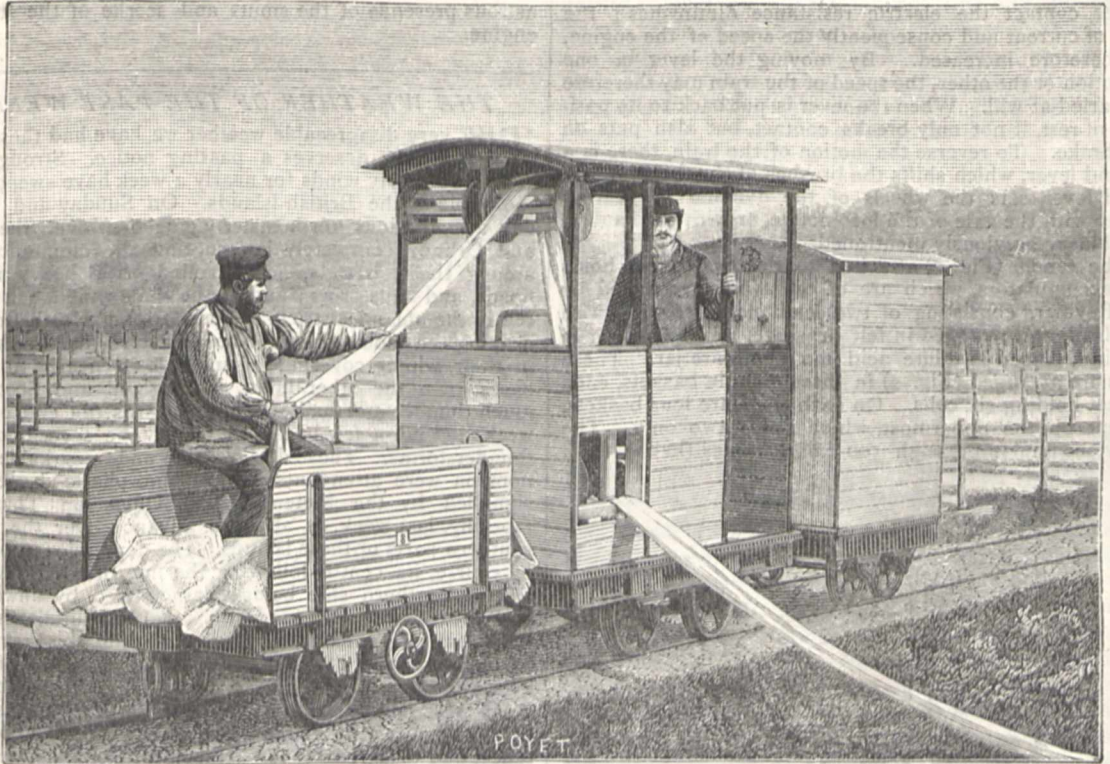

FIG. 3.—Hauling in the bleached linen.

truck (Fig. 3). Preferably all the linen pieces laid out upon the plot of neighbouring ground, are united to one another by their ends, so that a single workman can pick up 5000 metres of linen in thirty minutes, an operation

usually requiring eleven hours to perform. Fig. 4 shows the train of little trucks returning loaded with 10,000 metres of linen. Having thus described the general system, it will be convenient to examine the details.

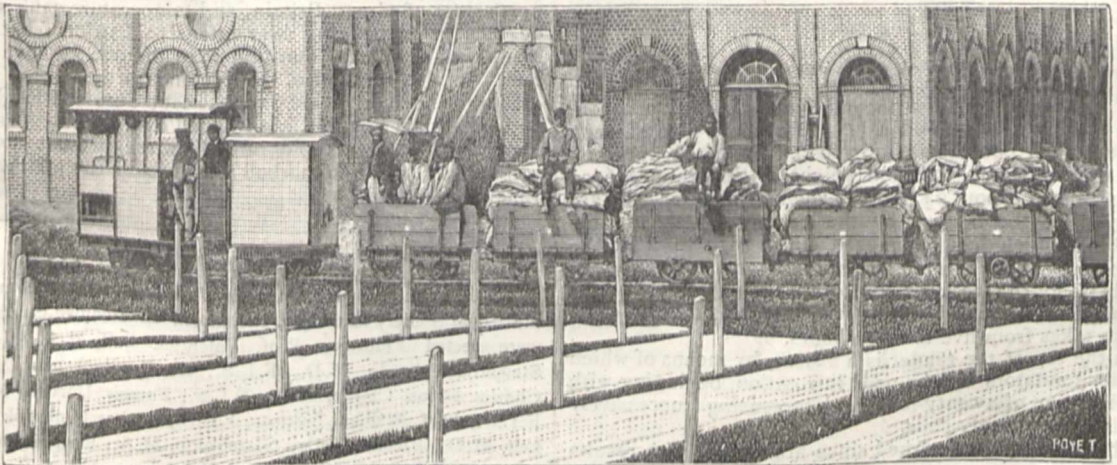

FIG. 4.—The return of the electric train from the bleaching ground.

The motor, or locomotive (Fig. 1) consists, as we have said, of a Siemens' dynamo capable of being reversed at will. The armature rotates very rapidly, the motion being reduced by a chain-gearing in the proportion of 1

to 9. A lever handle (see Figs. 1 and 5) controls the machine. As shown in Fig. 5, in a vertical position the brake is on, and no electrical action is taking place. By lowering the lever, contact is made, enabling the electric

current to flow. A "rheostat-chain," the invention of M. Reynier, who in 1881 applied a similar device to a sewing machine driven by electricity at the Paris Exposition, is thereby stretched. As its tension increases, there is better contact electrically between its links, and with this better contact the electric resistance diminishes; the flow of current and consequently the speed of the engine, is therefore increased. By moving the lever in one direction or the other, the speed of the train may therefore be varied at will. When the lever is put back to its position of rest, it not only breaks contact, but also puts on the brake. To reverse the motion of the train, there is a second lever, which shifts the brushes of the dynamo. A third lever sets the wheels of the dynamo in gearing either with the axle of the locomotive, or with the hauling machinery previously mentioned.

The tender (Fig. 2) attached to the locomotive holds the accumulators, which are of the type constructed by M. Reynier, consisting of two lead plates covered with red lead, and wrapped in felt or serge, rolled together in a spiral, placed in dilute acid in a stoneware jar. These cells are arranged (Fig. 2) in three tiers in baskets, each basket holding six cells. On each shelf are four baskets, except on the uppermost, which holds two only. The sixty accumulators weigh 500 kilogrammes (half a ton).

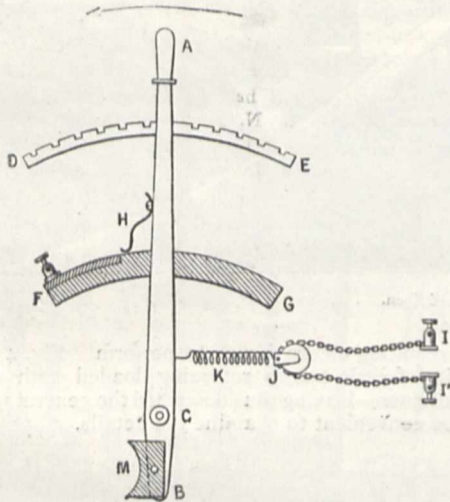

Fig. 5.—The starting-gear, with chain rheostat.

The total weight of the locomotive is less than a ton, that of the tender 700 kilos. (1543 lbs.), and that of each loaded truck 800 kilos. (1763 lbs.). With the workmen and six passengers, the total weight of the train is 6400 kilogrammes (about 6½ tons). The accumulator cells are charged at the factory by the current of a Gramme machine, which has been used since 1879 to light the establishment by eleven Reynier lamps. The power available in the works is 60-horse. Only 3 horse-power is, however, required during the charging of the cells, which takes from five to eight hours.

In the top of the tender is a switch, by means of which the accumulators can be used in rotation, beginning with a minimum of twenty-four, and increasing successively by sixes up to sixty cells.

This railway has worked since March last with results advantageous in every way. The speed of the train attains 12 kilometres (about 7½ miles) per hour; but in this special case, great speed is not desired. According to the information furnished by M. Dupuy, the train can work for three hours; being limited only by the charge that can be imparted to the accumulators.

This application of electricity to a purpose for which a steam-engine would be out of the question, is not only

novel, but suggestive. We feel disposed to query how long it will be before that great section of the public of London who travel by the Metropolitan Railway, insist that their lungs and eyes have as much claim as the linen of M. Duchesne-Fournet to be protected from the disastrous presence of the smuts and scoræ of the steam-engine.

THE WEATHER OF THE PAST WEEK

THE very disagreeable weather we have had these last few days deserves a passing notice. Strong persistent northerly winds for nearly a week have swept over the whole of the British islands. On Sunday and Monday a continuous north-easterly gale blew over Shetland and Orkney, completely interrupting all communication among these islands, accompanied with heavy rains, floods, and hailstorms; and at the same time much snow fell in the upland districts of the interior of North Britain, draping the mountains of Aberdeenshire and Perthshire in their winter covering of snow down nearly to their bases. On the other hand, in England and Scotland, much thunder and hail occurred towards the end of last week, and not a few lives were lost by the severity of the thunderstorms. These disagreeable and remarkable phenomena were attendants on an atmospheric depression signalled by the Meteorological Office on Thursday morning, last week, as about to advance over the more southern parts of these islands. The depression appeared in course, its centre following the line of the Cheviots; and its northern side being characterised by unwonted high pressures, it proceeded with singular leisureliness over the North Sea, and only reached Christiania by the morning of Monday. The slow onward rate of motion of this cyclone, the steep gradients formed on its north and north-west sides, and its southerly route across the North Sea readily explain the extent, strength, persistence, and disagreeably low temperature of the gale, and the unseasonable snowfalls which accompanied it. It is to such low depression-centres brooding over or slowly crossing the North Sea, that we owe our coldest summer weather; and it is a continued repetition of these in the critical months of June, July, and August that brings disaster to the farming interests. In the middle of June, 1869, a similar storm occurred when equally strong winds prevailed, when even more snow fell, particularly in the north-west of Great Britain, and temperature sank some degrees below freezing over extensive districts; but the storm was of shorter duration than the one we have just had. In this case, also, the cyclone formed steep gradients for northerly winds, and its centre crossed England and the North Sea, but it advanced over North-Western Europe at a more rapid rate than the present storm, which has formed so marked a feature of the weather of June, 1882.

NOTES

WE take the following from the *Times*:—At the meeting of the Royal Society last week, the fifteen undernamed candidates were elected Fellows:—Prof. Valentine Ball, M.A., George Stewardson Brady, M.D., F.L.S., George Buchanan, M.D., Charles Baron Clarke, M.A., F.L.S., Francis Darwin, M.A., F.L.S., Prof. William Dittmar, F.C.S., Walter Holbrook Gaskell, M.D., Richard Tetley Glazebrook, M.A., Frederic Ducane Godman, F.L.S., Prof. Jonathan Hutchinson, F.R.C.S., Prof. Archibald Liversidge, F.G.S., Prof. John C. Malet, M.A., William Davidson Niven, M.A., Robert Henry Inglis Palgrave, F.S.S., Walter Weldon, F.C.S.

It is interesting to notice, that in connection with the vote of sympathy of the Common Council on the death of Garibaldi, the Lord Mayor stated that "on the death of the great philo-

sopher and man of science, Mr. Darwin, he received over twenty telegrams from cities in Italy, expressive of Italian sympathy with the loss this country had sustained."

WE have received from Bucharest a little *brochure* of the greatest interest, in the shape of a translation into Roumanian of Sir John Lubbock's British Association address, "Fifty Years of Science," by Prof. J. P. Licheropol. The translation, we learn from the title page, is made from the report in *NATURE*. Prefixed is a brief address to Sir John Lubbock, which is written in vigorous and almost perfect English. "Your 'Fifty Years of Science,'" the translator writes, "has impregnated itself in the heart of the people who populate the plains and mountains of the Lower Danube. The scientific truths and literary beauties of such a work of genius cannot remain unknown to the Roumanians; I therefore took upon myself the pleasing duty of making it more known among them. I beg of you, therefore, to glance at it, and to receive it as your own; you will recognise it, perhaps, by its forms, which are impossible to be changed." As the translator styles himself Professor of Natural History and Physical Science, ex-Assistant Naturalist to the Museum of Natural History, and preparator in the Chemical Laboratory; and as a list of other scientific works, original and translated, is prefixed, it is evident that science has a hopeful place in Roumanian education and literature.

A COMMITTEE of members of the Academy of Sciences, the Academy of Medicine, the Society of Agriculture, and the faculty of science in the Superior Normal School of Paris, has been formed for the purpose of presenting to M. Pasteur a medal in commemoration of his fruitful researches.

WE regret to announce the death of Mr. Scott Russell, the eminent engineer, which took place on Thursday morning last, in the seventy-fifth year of his age. John Scott Russell, according to *Engineering*, was the eldest son of the Rev. David Russell, a Scotch clergyman. His great predilection for mechanics and other natural sciences induced his father to allow him to enter a work-shop, to learn the handicraft of the profession of an engineer. He subsequently studied at the Universities of Edinburgh, St. Andrews, and Glasgow, and graduated at the last at the early age of sixteen. He had attained to such proficiency in the knowledge of the natural sciences, that on the death of Sir John Leslie, Professor of Natural Philosophy in Edinburgh, in 1832, the young Scott Russell, though then only twenty-four years of age, was elected to fill the vacancy temporarily, pending the election of a permanent professor. About this time he commenced his famous researches into the nature of waves, with the view to improving the forms of vessels. His first paper on this subject was read before the British Association in 1835. The interest created by this paper was so great that a committee was appointed by the Association to carry on the experiments at their expense. Mr. Scott Russell discovered during these researches the existence of the wave of translation, and developed the wave-line system of construction of ships in connection with which his name is so widely known. In 1837 he read a paper before the Royal Society of Edinburgh, "On the Laws by which water opposes resistance to the motion of floating bodies." For this paper he received the large gold medal of the Society. In 1844 Mr. Scott Russell removed to London. In 1847 he was elected a Fellow of the Royal Society. He for a short time occupied the post of the secretary of the Society of Arts, which place he resigned to become joint secretary with Sir Stafford Northcote of the Great Exhibition of 1851. He was, in fact, one of the three original promoters of the Exhibition, and under the direction of the late Prince Consort, took a leading part in organising it. Mr. Scott Russell was for many years known as a shipbuilder on the Thames. The most important work he ever constructed was the *Great Eastern* steam-

ship. Mr. Scott Russell was one of the earliest and most active advocates of ironclad men-of-war, and he has the merit of having been the joint designer of our first sea-going armoured frigate the *Warrior*. In early life he took a great interest in steam locomotion on ordinary roads, and while at Greenock he constructed a steam coach which ran for some time successfully between Greenock and Paisley. His greatest engineering work was without doubt the vast dome of the Vienna Exhibition of 1873. The last engineering work which Mr. Scott Russell ever designed was a high level bridge to cross the Thames below London-bridge. It was intended to cross the river with a span of 1000 feet, and to allow of a passage beneath it for the largest ships.

THE death is announced of Mr. James Spence, Professor of Surgery in Edinburgh University, in the 70th year of his age.

WE regret to announce the death of Dr. P. A. Bergsma, late director of the Batavia Observatory. He died on May 1, during his passage through the Red Sea, on the way home from India. We quite recently announced the retirement of Dr. Bergsma from his post in Batavia Observatory, where he has done so much good work.

IN anticipation of the jubilee meeting this year the *British Medical Journal* devotes most of its last number to a Historical Sketch of the British Medical Association.

As a result of the action taken by the Essex Field Club with reference to the preservation of Epping Forest in its natural condition, a conference was held on Friday evening, June 9, at the residence of Mr. E. N. Buxton at Woodford. Of the veriders there were present besides Mr. Buxton, Sir T. Fowell Buxton, and Mr. Andrew Johnston. The scientific claims of those to whom the preservation of the forest as such is a matter of importance, were ably advocated by many well-known naturalists who had been invited to take part in the discussion. Among the speakers were Dr. Henry Woodward, Dr. M. C. Cooke, Mr. J. E. Harting, Mr. Charters White, the President of the Quekett Club, Mr. G. S. Boulger, and Messrs. R. Meldola and Wm. Cole, the President and Secretary of the Essex Field Club. The results of the conference were, as we learn, satisfactory with respect to the future of the forest.

THOSE entomologists who study fossil insects, and palæontologists generally, should feel grateful to Mr. S. H. Scudder for having compiled "A Bibliography of Fossil Insects," forming No. 13 of the "Bibliographical Contributions" appearing in the *Bulletin* of Harvard University. It extends (including an appendix) to 47 pages in double columns, and must include nearly 1000 references, to each of which, as a rule, are appended a few lines of explanatory notes. The subject is made to include spiders and myriopods, in addition to true insects. No trouble appears to have been spared in order to render it as complete as possible; on this point Mr. Scudder laments that the enormous increase of popular literature that has taken place latterly, containing hosts of minor papers wholly popular in character, has vastly increased the labour of compilation without corresponding advantage. He doubts if as much activity is now shown in the department of fossil entomology as when the labours of Heer gave a sudden impetus to its study. Possibly the often eminently unsatisfactory and speculative nature of the subject has something to do with this.

WITH reference to Prof. Riley's extracts from Dr. Macgowan's papers on the utilisation of Ants in Horticulture, in China, a correspondent calls our attention to a long article in the *Ceylon Observer* for April 26, in which is reprinted the following extract from Tennent's Natural History of that island:—"To check the ravages of the coffee bug (*Lecanium coffea*, Walker), which for

some years past has devastated some of the plantations in Ceylon, the experiment was made of introducing the red ants, who feed greedily on the coccus. But the remedy threatened to be attended with some inconvenience, for the Malabar coolies, with bare and oiled skins, were so frequently and fiercely assaulted by the ants as to endanger their stay on the estates."

The *Revue Scientifique*, one of the most influential scientific periodicals in France, has been purchased by a company for the purpose of extending its publication and improving its programme.

ON Tuesday evening Mr. Keane exhibited at the Anthropological Institute, on behalf of the finder, Mr. M. S. Valentine, of Richmond, Virginia, some very remarkable stone objects recently discovered by that archaeologist in the neighbourhood of Mount Pisgah, North Carolina. In the course of his remarks Mr. Keane explained that these were merely a few typical specimens selected from an extensive collection of over 2000 articles, partly in stone and partly in micaceous clay found in this upland region, between the Alleghany and Blue Mountains, during the years 1879-82. The material of the stone objects is almost exclusively steatite, or soap-stone, which abounds in the district, and which might almost seem to have been sculptured with metal instruments, so perfect is the workmanship. The objects themselves are absolutely of a unique type, consisting partly of human and animal figures, either in the round or in various degrees of relief, partly of household utensils, such as cups, mugs, basins, dishes, and the like, partly of purely fancy, and other miscellaneous articles, illustrating the tastes, usages, and culture of the unknown people by whom they have been executed. Collectively they present, Mr. Keane maintains, a unique school of art developed at some remote period in a region where the presence of civilised men had not hitherto been even suspected. The human type, which presents great uniformity, while still by no means conventional, is distinctly non-Indian, according to Mr. Keane, but whether Mongolic or Caucasian it would at present be premature to decide. All are represented as fully clothed, not in the hairy blanket of the Red Man, but in a close-fitting well-made dress somewhat after the modern "united garment" fashion. Some are seated in armchairs exactly resembling those known as "Ingestre Chairs," while others are mounted on the animals, which they had domesticated. These animals themselves are stated to be marvellously executed. Some of them represent the bear, the prairie dog, and other quadrupeds, as well as birds of North America. But others seem to represent types of the Old World, such as the two-humped Baktrian camel, the rhinoceros, hippopotamus, and European dog. There are also some specimens obviously executed since the appearance of the white man, as shown by the horse with his rider, firearms, shoes, &c. The material of all these has a much fresher look than the others, and is of much ruder workmanship, as if they were the work of the present race of Indians. These races are undoubtedly of the pure Indian type, Mr. Keane stated, and recognised themselves as intruders in this region, where they had certainly been preceded by more civilised peoples, such as the Mound-builders and others, of whom they had traditions, and whom they had extirpated long before the arrival of the Europeans. Amongst these extinct peoples were the Allegs or Alleghewis, whose name survives in the "Alleghany Mountains." These Alleghewis are said to have been a different race from the Indian, and it is possible, Mr. Keane thought, that in their new homes in the Alleghany uplands they may have continued or developed the culture of which we have met remarkable evidence in these stone objects. It is evident, however, that before any conclusions can be built on this interesting find, the con-

ditions under which it was found must be carefully sifted by archaeological specialists.

THE Municipal Council of Paris has voted the funds for executing six aeronautical ascents on the occasion of the festivities of July 14 next. Two of these balloons will be connected by a telephone wire in order to keep up constant verbal communications. These two connected balloons will ascend from the Place du Trone. It is hoped that by sending up balloons so connected many interesting observations can be made for the velocity of sounds at different altitudes, the differences of temperature of velocity of wind and of direction, &c., as well as differences of electrical tension.

DURING the progress of some excavations on Lord Normanston's estate, near Crowland, Peterborough, the workmen have exposed about three acres of a subterranean forest 10 feet below the surface. Some of the trees are in an admirable state of preservation, and one gigantic oak measures 18 yards in length. The trees are in such a condition that oak can be distinguished from elm, while a kind of fir tree seems to be most abundant, the wood of which is so hard that the trees can be drawn out of the clay in their entirety. The surrounding clay contains large quantities of the remains of lower animal life.

THE working of subterranean telegraphic lines is stated to be unsatisfactory in France and in Germany as well, and it is doubted whether the process shall be continued in France, although credits have been voted by the French Parliament for a sum of several millions of francs. These circumstances ought to be carefully investigated, as it is contemplated, we understand, to introduce the continental subterranean method into this country.

M. COCHERY, the French Minister of Postal Telegraphy, has decided that the electrical laboratory established with the proceeds of the late Electrical Exhibition will be placed in the Bois de Boulogne. The reason alleged is the necessity of avoiding the shaking of the ground by the passing of carriages so frequent in Paris. The establishment will be open to the public under certain limitations and regulations, which will be printed in the *Journal Officiel*. The development of the institution will be only gradual, the profits realised amounting to only 300,000 francs, and the total sum required to 1,000,000 francs.

THE works of the French Company for the Channel Tunnel are progressing favourably. A number of workmen are engaged in mounting the engine designed by Col. Beaumont, which is placed in the lower gallery, and will be in working order in a few weeks. The boring will be executed under the supervision of an English foreman, who conducted the excavation of the first 500 metres on the English side.

FROM the Report of the Mitchell Library, Glasgow, it seems evident that it is in a fair way of becoming one of the first libraries in the kingdom; the avowed aim of its trustees is to make it for Glasgow what the British Museum Library is for London. It contains already 40,000 volumes, a large proportion of which are scientific. The number of works taken out during the year in "Art, Science, and Natural History" (a curious classification), bore a large proportion to those on other subjects.

MR. JOSEPH SIMMONS, the balloonist, made a journey on Saturday in his balloon the *Colonel* from Maldon in Essex, across the Channel to beyond Arras in France, a distance of 170 miles, in one hour and three-quarters.

A PECULIAR and interesting auroral phenomenon, witnessed from the steamship *Atlantic* off the Newfoundland coast, on

September 12 last year, has been described by Mr. Engler to the St. Louis Academy. While an aurora of normal type was clearly seen in the northern sky, there appeared in the south-east, about 30 to 35 deg. above the horizon two horizontal streaks of light, about 5 deg. apart, and 15 or 20 deg. in length. Their pale hazy light resembled moonlight. From the upper streak were suspended, by small cords of light, a number of balls, brighter than either of the streaks, which were continually jumping up and down in vertical lines, much like pith-balls when charged with electricity. Above the upper streak was a bright gauze space with convergent sides, seemingly composed of streamers of light, the brightness diminishing from the streak outwards. From the lower streak extended a similar mass, differing only in a greater inclination of the streamers. The balls and cords gradually disappeared first, then the streamers, then the streaks; and the whole phenomenon lasted about half an hour. No explanation is offered. It is noteworthy that on the same evening and at the same hour, a most remarkable band of white light was seen at Albany, N.Y., Utica, N.Y., Hanover, N.H., Boston, Mass., and elsewhere in the North Atlantic States, spanning the heavens from east to west near the zenith.

THE sixth part of the *Transactions* of the Cumberland Association for the Advancement of Literature and Science, is a volume of 180 pp., and comprises the annual reports of the different local societies, amalgamated under the title, with a selection of papers read before the Association and the local societies. We have already given full details of the formation and working of the Association. The report of the secretary, Mr. J. D. Kendall, F.G.S., is encouraging, showing, that though there is a slight falling off in the number of members, due to the cause already noticed, there are now 1811 on the books. The present volume of *Transactions* is one of the most valuable the Association has yet published. It is divided into two parts, the first containing the President's address and the papers read at the annual meeting, and the second consisting of papers communicated to the different societies, and recommended by the Council for publication. Among the papers are—Public water-supplies of West Cumberland, by Mr. A. Kitchin, F.C.S.; Grasses of Mid-Cumberland, by Mr. W. Hodgson; Observations on the flowering-plants of West Cumberland, by Mr. J. Adair; the lichens of Cumberland, by Rev. W. Johnston; Notes on the occurrence of the Iceland falcon in Edenside, by Mr. J. G. Goodchild, accompanied by an excellent drawing of the bird; and Physical geography of North-West Cumberland, by Mr. T. V. Holmes. The second part includes an historical sketch, "The Chaloners Lords of the Manor of St. Bees," by Mr. W. Jackson, F.S.A., and an exceedingly interesting paper on bird-life, by Dr. Chas. A. Parker. Mr. Holmes contributes notes on a submerged forest off Cardurnock, on the Solway, and on the destruction of Skinburness by the sea about the year 1305. A valuable list of West Cumberland flowering-plants and ferns, by members of the Botanical Section of the Whitehaven Society, records the observed plants of the district. This appears to be the most complete list that has yet been published, though a few errors have crept in. The concluding paper is on the distribution of the Diatomaceae, by Mr. B. Taylor, and consists of a list of the species obtained by him in the locality.

IN reference to Mr. S. M. Baird Gemmill's letter on the Aurora (*antea*, p. 105), the writer asks us to state that the aurora was observed on May 15th (not the 18th).

THE additions to the Zoological Society's Gardens during the past week include a Sykes's Monkey (*Cercopithecus albogularis* ♂) from West Africa, presented by Mr. Ballantine Dykes; a Common Marmoset (*Hapale jacchus*) from Brazil, presented by Mrs. Wingfield; a Yellow-bellied Liothrix (*Liothrix luteus*) from India, presented by Miss Mabel Crosbie; two Common Night-

ingales (*Daulias lusciniæ*), a Blackcap Warbler (*Sylvia atricapilla*), British, presented by Mr. H. Grant; a Horned Lizard (*Phrynosoma cornutum*) from Texas, presented by Mr. David Rowell; a Common Nightingale (*Daulias lusciniæ*), British, two Yellow-bellied Liothrix (*Liothrix luteus*) from India, deposited; two Wood Larks (*Alauda arboræ*), European, received in exchange; two Japanese Deer (*Cervus sika* ♂ ♂), two Mouflons (*Ovis musimon* ♂ ♂), a Cape Buffalo (*Bubalus caffer* ♂), born in the Gardens. The following insects have emerged during the past week:—Silk Moths: *Samia cecropia*, *Attacus mylitta*, *Attacus Cynthia*, *Actias selene*; Butterflies: *Lycana iolas*, *Limenitis silybia*, *Argynnis paphia*, *Vanessa urtica*, *Papilio podalirius*; Moths: *Sphinx pinastri*, *Cherocampa elpenor*, *Sesia formiciformis*, *Sesia conopiformis*, *Sesia musceformis*, *Trochilium apiforme*, *Trochilium melanocephalum*, *Sciapteron tabaniforme*, *Callimorpha dominula*, *Odonestis potatoria*.

OUR ASTRONOMICAL COLUMN

MASKELYNE'S VALUE OF THE SOLAR PARALLAX.—Several inquiries have been lately made with regard to the authenticity of a value of the sun's parallax, attributed in many works to Maskelyne, the former Astronomer-Royal.

This value (8"723) was deduced by Maskelyne in an application of what he calls a new method of determining the effect of parallax on transits of the inferior planets, and is given in an article which he appears to have communicated to Vince, Plumian Professor of Astronomy at Cambridge, who published it both in his large work, "A Complete System of Astronomy," and in his elementary treatise intended for the use of students in the University. We have not been able to consult the earlier editions of these works, to ascertain whether, as is probably the case, the article was published in Maskelyne's life-time, but it is found in Vol. I. of the "System of Astronomy," which appeared in 1814, and is dedicated to Maskelyne, and also in the fourth edition of the "Elements of Astronomy," Cambridge, 1816. The article is entitled "A new method of computing the effect of parallax, in accelerating or retarding the time of the beginning or end of a transit of Venus or Mercury over the sun's disc, by Nevil Maskelyne, D.D., F.R.S., and Astronomer-Royal." After explaining his method and how an approximate value may be corrected, as a numerical example he compares the duration of the transit of Venus in 1769 as observed at Wardhus and Otaheite, assuming as an approximate value of the mean horizontal parallax 8"83 (nearly that found by Du Séjour), and concludes: "Hence the mean horizontal parallax of the sun = 8"83 × (1 - 0'0121) = 8"72316." In the "Elements of Astronomy" there is the additional sentence: "we assume, therefore, the mean horizontal parallax of the sun = 8"723"; but this does not appear in Vince's larger work, nor is it quite clear whether it is an addition of Maskelyne's or his own."

Lalande says the first edition of Vince's "Elements of Astronomy" was published in 1790, and Vol. I. of the large work in 1797. Probably some of our readers may be able to refer to the earlier editions.

COMET 1882a (WELLS, MARCH 17).—The following ephemeris of this comet is deduced from the elements last given in this column:—

	R.A.		Decl.		Log. distance from	
	h.	m. s.	+	-	Earth.	Sun.
July 1 ...	9 35	58 ...	+11	57'0 ...	0'0501 ...	9'8925
3 ...	9 50	49 ...	11	23'2 ...	0'0673 ...	9'9205
5 ...	10 4	21 ...	10	50'2 ...	0'0850 ...	9'9461
7 ...	10 16	43 ...	10	18'2 ...	0'1027 ...	9'9697
9 ...	10 28	2 ...	9	47'4 ...	0'1202 ...	9'9916
11 ...	10 38	26 ...	9	17'9 ...	0'1375 ...	0'0120
13 ...	10 48	1 ...	8	49'6 ...	0'1545 ...	0'0310
15 ...	10 56	54 ...	+ 8	22'4 ...	0'1711 ...	0'0489

On July 1, the comet sets 1h. 44m. after the sun at Greenwich, and the theoretical intensity of light is equal to that on May 16; on July 15, it sets 1h. 50m. after the sun, with a brightness equal to that on April 19.

On June 7, Mr. Barber of Spondon, Derby, observed the comet with his 8-inch refractor, at 8h. 30m., or less than ten minutes after sunset: there was a large white disc, but no tail was visible at this time.

† A SUSPECTED VARIABLE STAR.—Mr. S. M. B. Gemmill writes from Glasgow, expressing the opinion that ϕ Draconis will prove to be a variable star. For some time past he has observed it to be almost equal to χ in the same constellation, whereas Groombridge and others had given a difference of one magnitude. The "Durchmusterung" has 4.7 and 3.8 for these stars respectively, and the first Radcliffe catalogue, for which the magnitudes were very carefully estimated, has 4.4 and 3.7. Heis assigns a difference of half a magnitude. Mr. Gemmill states he has found a very slight fluctuation in ψ^1 Draconis, which seems to be periodic. Baily, in his notes to the *British Catalogue*, says: "This star is marked as of the 7th magnitude in the *British Catalogue*; but in the original entries it is designated once as 4 $\frac{1}{2}$, once as 3 $\frac{1}{2}$, and once as the 5th."

THE UNIVERSITY OBSERVATORY, OXFORD.—The Savilian Professor of Astronomy, director of the University Observatory, has issued his annual report, which was presented to the Board of Visitors on the 1st inst. It is mentioned that a somewhat elaborate memoir is now printed in the *Transactions* of the Royal Astronomical Society on the application of photography to delicate celestial measurement. The inquiry into the relative motions of some forty stars in the Pleiades has been brought to a successful conclusion, the results agreeing generally with those recently deduced by M. Wolf, of the Observatory at Paris, who employed a very different instrument and method. A complete survey of the relative brightness or magnitudes of all the stars in the northern hemisphere reputed to be visible to the naked eye has been commenced, and it is hoped that before the date of the next report, all the stars brighter than the fifth magnitude, some five hundred in number, will have been measured. The report touches also upon the discordances between the observed degree of brightness of Comet 1882 *a*, with the results deduced from theory. The expenditure for the purposes of the Observatory, has, it is stated been under the amount provided by Convocation; a sum of 600*l.* per annum is available for three years from December last, and this the Savilian Professor considers will probably suffice for the future efficient maintenance of the Observatory, the only difficulty that might arise relating to necessary repairs, &c., of the present instruments, or the addition of new ones that may be needed.

GEOGRAPHICAL NOTES

M. LESSAR's paper on his excursion from Askabad to Saraks (*Izvestia*, vol. xviii, fasc. 2) will be read with pleasure by those who are interested in the topography, inhabitants, and social conditions of this country. With regard to natural science, we notice the result of the levelling which was made along the line of the Transcaspien railway; it proved, that contrary to what was presumed, the country does not have a general slope from east to west. At the Aidin wells there are several places situated below the present level of the Caspian, and all the tract between this place and the present shore of the Caspian—M. Lessar states—cannot be regarded as the former bed of a river; it was probably the bottom of a very large gulf of the Caspian, which extended towards the east. It is most probable—he adds—that a levelling between the Tekke oasis and Khiva or Bokhara, will also show in the sand-steppes many tracts situated below the level of the Caspian, as has been found in the Sara-kamysh depression; and it will prove that the Murghal and Tejent could not flow into the Oxus, but flowed into the Caspian, much extended at that time towards the east. We notice in the same paper a remark with regard to termites; their hemispherical mounds, one to two feet in diameter, are very numerous in certain localities; numberless galleries are discovered under these mounds, which galleries are peopled with ants and with termites, about half an inch long, of an amber-colour; they cover the brushes and pieces of wood with numberless pipes in clay, and totally destroy them. The buildings of the Transcaspien railway have much to suffer from the attacks of the termites.

We have received from Mr. Fisher Unwin several of his useful "Half-Holiday Handbooks." They are all for the districts around, and easily accessible from London. They are really handy, in paper covers, easily carried in the pocket, and well printed. Considering their low price, they contain a great deal of varied information and many useful and well-executed

illustrations. Besides the objects which attract the ordinary tourist, they give a fair amount of information concerning the natural history of the districts to which they refer, and illustrations of the principal flowering plants, and occasional geological curiosities. We have no doubt these "Handbooks" will meet with a wide sale; and we trust they will be the means of encouraging hard-worked Londoners to explore the beauties and natural productions of the interesting district around the metropolis. The districts so far included in the series are Richmond, Bromley and Keston, Kingston-on-Thames, Tunbridge Wells, Greenwich and Blackheath, Reigate, Croydon to the North Downs, Dorking. With the exception of Kingston, they have all maps and bicycle routes. As a general accompaniment to these, there is one volume devoted to geological rambles and tours, with twenty-five illustrations and sketch-maps.

"DIE Afrika-Literatur in der Zeit von 1500 bis 1750 N.Ch." is the title of a small volume by Prof. Philipp Paulitschke, published by Brockhausen and Bräuer of Vienna. It consists of the titles, with other bibliographical information, of 1212 works and papers and maps on Africa, published during the period embraced. These are arranged under five headings—General, North, West, South, and East Africa. Prefixed is a short, scholarly, and useful introduction on the growth of our knowledge of Africa from 1500 to the time of the great map reformer, D'Anville. The great utility of such a work must be obvious to all, and geographers owe a debt of gratitude to Dr. Paulitschke for the great trouble he has been at in compiling the list, involving, as it must have done, extensive research and correspondence. No doubt omissions will be found that can be supplied in subsequent editions, but the work could scarcely have been better done. We should be glad to know on what authority Dr. Paulitschke states that Lobo's "History de Ethiopia" was published at Coimbra in 1859. In the great Portuguese Bibliography there is no mention of its publication, except as embodied in Tellez's "Historia Geral" of 1660. The translation into French by Legrand was made from MS. Under North Africa is given Sir Peter Wyche's "Short Relation of the River Nile," which should have been under East Africa, as it is really only a translation of part of Lobo's narrative published by the Royal Society in 1669. But these are comparatively small matters.

DR. FRIEDRICH EMBACHER'S "Lexikon der Reisen und Entdeckungen" is a little work that will be welcome to all interested in the history of geographical discovery; it is published at Leipzig at the "Verlag des Bibliographischen Instituts." It seems to be one of a long series of reference-books ("Meyer's Fach-Lexika") relating to different subjects. Dr. Embacher's volume is neat and well printed; contains brief notices of the leading geographical explorers, from the earliest times down to the present day, including even those now living; for example, there is a long notice of Stanley, and another of Prjevalsky. The first part is followed by a sketch of the progress of exploration in each of the great divisions of the world. The work seems to us to be done with great care, and the bibliographical references will prove very useful. The only omission of importance is the name of Mr. Darwin, which, since the work includes the names of Sir J. D. Hooker, the late Mr. Belt, and even the late Dr. Leared, surely ought to have found a place.

FROM Ferdinand Hirt of Breslau, we have received a volume of "Geographische Bildertafeln," edited by Dr. Oettel of Bremen, and Dr. Ludwig of Leipzig, with the co-operation of several specialists. This is only the first part, and is devoted to general geography. It consists of a series of carefully selected and arranged pictures, illustrating everything that ought to come under the general subject, which, in the German acceptance, seems to be a very wide one. There are in all, twenty-four sheets, containing a varied selection of illustrations of such subjects as the general surface of the earth and instruments of measurement, the geological periods, geological faults, mountain types, glaciers, volcanoes and hot springs, hills and plains, islands and coasts, oceans and seas, harbours natural and artificial, rivers, navigation, charts and meteorology, woods and forests, ethnography, scenes and means of travel, the chase, and so on. The utility of such a collection of pictures is evident. The selection seems to us to be carefully made, many of the illustrations being from well-known books of travel. As a supplement to any text-book of geography, it would be of great service, and would be sure to be welcome to the pupil.

A NEW THERMOGRAPH¹

THE instrument under consideration is a thermograph for recording the atmospheric temperature, the fluctuations of which are much less regular and more frequent than one who has not made a study of it would suppose. It records the temperature directly from the column of mercury in the tube of a thermometer by dots or perforations upon a sheet of paper previously ruled with degrees and hours.

Its principal parts are, as shown in Fig. 1 of plate:

1. A thermometer in the form of an ordinary mercury thermometer, but open at the top of the tube, and having a wire entering the bulb and connected to one pole of a battery, the other pole of which is connected to the mechanism of the instrument.

2. An upright cylinder revolving by clockwork, covered with a paper which is divided vertically into twenty-four parts by lines representing the hours, and horizontally by lines representing the degrees.

3. A bar raised and lowered by mechanism driven by clockwork, furnished below with a needle entering the tube of the thermometer, and carrying a pencil—or preferably a point—driven forward by a small electro-magnet when the circuit is closed by the needle entering the mercury, and then making a mark at the proper place upon the paper and indicating the temperature.

The bar carrying the needle rises about half an inch from the point at which the needle leaves the mercury, and then descends until the needle touches the mercury, whether that in the meantime shall have risen or fallen, when the point makes its mark upon the paper and the bar again commences to rise.

This movement is accomplished by the mechanism shown in the drawing, of which only the wheel E, gearing into the rack upon the needle-bar, is shown in Fig. 1, but which is shown in full and upon an enlarged scale in Fig. 2, which is a top view. The two wheels A and B are moved by clockwork (not shown), and are constantly revolving in opposite directions, as indicated by the arrows. These wheels are not attached to the shaft upon which the wheel E is fixed, but are attached to sleeves which move without affecting that wheel except when they are joined to it by the clutches C or D. They are so geared that when the wheel E is joined to them, its rim moves at the rate of half an inch per minute. Upon the shaft with the wheel F is also a loose sleeve F, which is free when the clutch C is not in action, but which moves with that wheel when that clutch is on.

The levers actuating the two clutches unite and move upon a common pivot, from which point they extend as an arm, which is capable of a lateral movement between two stops, bringing one or the other of the clutches into action.

Opposite to the wheel E, the needle-bar passes through a guide, which is furnished on the back with a small wheel taking the thrust of the gear and reducing friction. For a lower guide, the needle-bar is furnished on each side with a rod parallel to the needle, and of nearly the same length. These rods are at such distance apart that they pass clear of the thermometer tube. They are not shown in the drawing, as they would lie directly in front of and behind the needle and tube.

The teeth of the clutches are partly V-shaped and partly square, or nearly so, as shown in Fig. 3; that is, they have slightly tapered sides but V-shaped points and bases, so that they enter freely, as entirely V-shaped teeth would do, and when in action they have no outward thrust. The V-shaped base strengthens the tooth and admits the point of the opposite tooth.

A very small spring on each side of the sleeve F holds it out of gear while the clutch C is off.

Beneath the clutch arm is a pressure spring, one end of which presses against the end of the arm, and the other against a plate moving upon the same pivot with the arm, which plate also is capable of a lateral movement between its stops.

If this spring-plate is moved in either direction to its stop, carrying with it the base of the spring, the clutch-arm will be moved in the other direction, and the clutch on that side will be brought into action; and if the position of the spring-plate with the base of the spring be reversed, the position of the clutch-arm will be reversed—that clutch will be disengaged, and the other one will be engaged—the wheel E being moved, and the needle-bar raised or lowered accordingly.

To the sleeve F is attached an arm which is connected by a draft-rod to the spring-plate.

¹ A paper by G. Morgan Eldridge, read at the stated meeting of the Franklin Institute, April 26, 1882. Contributed by the Author.

When the clutch C is in action—as shown in the drawing—connecting the wheel A with the wheel E and the sleeve F, raising the needle-bar, the arm of the sleeve F draws upon the spring-plate—moving to that side the base of the reversing-spring, which, when its base has passed the line between the pivot and the end of the clutch-arm, presses that arm to the other side, disengaging that clutch, loosing the sleeve F, engaging the other clutch, and reversing the motion of the needle-bar, which now descends.

The length of the arm on the sleeve F is such that when the needle-bar has risen half an inch the spring-plate is moved over, and the clutch-action is reversed.

When, by descending, the needle is brought in contact with the mercury and a circuit is made, the large electro-magnet, thus utilised, attracts its armature, which is attached to a lever con-

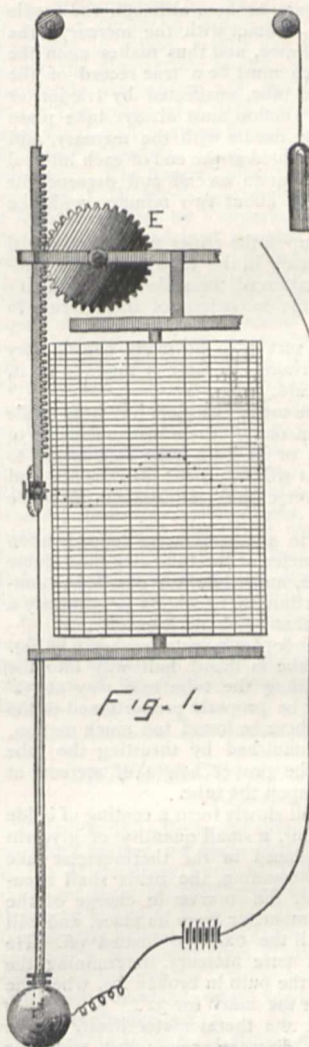

Fig. 1.

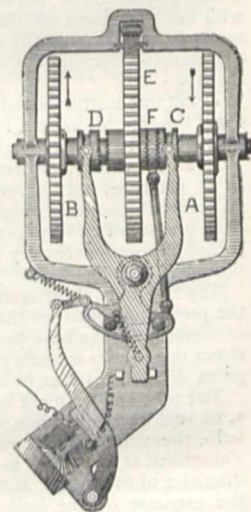

Fig. 2.

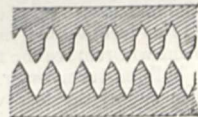

Fig. 3.

nected with and drawing upon the spring-plate, and moves the base of the reversing spring to that side, changing the position of the clutch-arm, and reversing the action of the clutches and the movement of the needle-bar, while at the same time the recording-point upon the needle bar is, by its electro-magnet, driven into the paper, and the temperature is recorded upon the scale.

The sleeve F, being loose, yields to the movement of the spring-plate, and is afterwards held by its clutch, and acts as before.

The action of the large electro-magnet is supplemented by that of a spring drawing upon the same side of the spring-plate, whose strength is such that it is not quite sufficient of itself to overcome the thrust of the reversing spring, but whose force is greatest when that of the electro-magnet, by reason of

its distance from its armature, is least, the greatest possible portion of the work being thus put upon the clockwork, and the least upon the battery.

This spring aids the electro-magnet, but does not in anywise reduce the effect of the reversing spring in holding the clutch to its work; so long as the base of that spring is unmoved, its action is unimpaired. The resistance of these springs occurs only during the ascent of the needle-bar, which is, therefore, counterpoised to excess, and the resistance and the motion are thus rendered uniform. By reason of the form of the clutch-teeth before described, there is no outward thrust upon the clutches while in action, and hence the reversing spring requires only to be strong enough to throw the arm over and to shift the clutches. The stop of the clutch-arm next the electro-magnet is an insulated plate, to which the battery-wire leading from the magnet is connected, so that as soon as the arm has left the stop the circuit is again broken, although the needle may for a short time remain in contact with the mercury; the recording-point is at once withdrawn, and thus makes upon the paper a single perforation which must be a true record of the position of the mercury in the tube, unaffected by friction or other disturbing cause, since this action must always take place at the moment of contact of the needle with the mercury, and these dots or perforations are repeated at the end of each interval of time required for the needle-bar to ascend and descend the required distance, which will be about two minutes with the wheel-motion designated.

The graduation of the scale upon the paper must correspond with the movement of the mercury in the tube of the thermometer as accurately as the graduation of the scale of an ordinary thermometer corresponds with the movement of the mercury in its tube.

If but one instrument of this sort is to be made this is very easy, the rate of motion is ascertained, a scale is made to fit it, and the paper is ruled to that scale.

In all thermometers heretofore made the scale has been made to fit the tube, but if more than one of these instruments is to be made, it becomes necessary, or at least very convenient, to have one set of ruled papers that will fit all the instruments, and it then becomes necessary to reverse the practice and to make the tubes to fit the scale.

The rise and fall of mercury in a thermometer depends upon the proportion between the diameter of the tube and the volume of mercury in the tube and bulb, and while it is possible to construct these parts in such proportion as to obtain approximately a given motion, it is not possible thus to obtain it exactly.

The tube and bulb are made in separate parts, as shown in Fig. 1, of such size that when the tube is thrust half way into the bulb, the volume of mercury filling the tube half way at 32° Fahrenheit is as nearly as may be properly proportioned to the diameter of the tube. If now there be found too much motion, the capacity of the bulb is diminished by thrusting the tube further in, and *vice versa*, and the proper height of mercury at 32° for that purpose is marked upon the tube.

Mercury exposed to the air will slowly form a coating of oxide upon its surface. To prevent this, a small quantity of glycerin or of oil free from oxygen is placed in the thermometer tube above the mercury. If, notwithstanding, the oxide shall accumulate to an inconvenient extent, the observer in charge of the instrument will remove the thermometer from its place, and will put the bulb in warm water until the oxide is floated off. He will then supply the loss with pure mercury, determining the proper quantity by immersing the bulb in broken ice, when the mercury column should stand at the mark for 32°.

The whole apparatus, except the thermometer itself, can be inclosed, and so protected from the weather and dust, while the thermometer is exposed to the air below.

The system is equally applicable to a barometric record, in which case, on account of the small range of motion, the needle-bar is connected to a lever, thus increasing the range of the record.

SCIENCE IN BOHEMIA¹

THE Bohemian Society of Science continues its useful career, which has already lasted for eighty-four years, and its latest publications (the *Memoirs*, the *Proceedings*, and the annual

¹ *Abhandlungen der Mathematisch-Wissenschaftlichen Classe der K. Böhmischen Gesellschaft der Wissenschaften, vom Jahre 1879-1880, vi Folge, Band x. (Prag, 1881).* "Sitzungsberichte" of the same Society, for 1879 and for 1880. "Jahresberichte" of the same, for 1879 and 1880.

Reports) contain many valuable papers, devoted partly to science in general, but mostly to the exploration of Bohemia itself in its various aspects. The last volume of its *Memoirs* ("Abhandlungen" for 1879-1880, series vi. vol. x.) contains a series of very interesting papers, each of them being the result of careful and extensive research. Prof. Franz Farsky gives the results of varied experiments which were undertaken at the experimental agricultural station at Tabor, on the growth of food-plants in water containing solutions of those salts which constitute the ash of the plant. The influence of alkaline and acid solutions, and especially that of chlorine, which proved to be a most important element of vegetation, were submitted to varied experiments, all the results of which are published in full. The general reader will notice with interest the beautiful results obtained by the culture of oats and barley in glasses of water, which contained the necessary salts, the plant being simply planted in a bit of cotton. Dr. F. J. Studnicka publishes in the same volume the complete tables of observations on the amount of rain in Bohemia during the years 1879 and 1880, at no less than 312 stations in 1879 and at 289 stations in 1880. If we remember that besides these stations there are very many others established by the Bohemian Foresters' Society, and that the whole number of stations where the amount of rain is accurately measured day by day, amounts to 800, we can see that Bohemia has probably the widest network of ombrological observations in Europe. We notice that the most rainy places in Bohemia are Maader, Rehberg, and Neuwelt (1744, 1572, and 1505 millimetres per year respectively), all these situated at great heights (985, 848, and 683 metres), whilst the less rainy places are Ropic, Slaten, and Kladno (431, 438, and 456 millimetres), situated respectively at altitudes of 322, 246, and 380 metres.

Dr. F. Ullik contributes a paper on the matter suspended and dissolved in the water of the Elbe, at Tetschen. Samples of water were taken three times every day, and the samples of each day were analysed separately with regard to the matter suspended, as well as to the quantity of chlorine, ammonia, nitric acid, and organic substances. Besides, 22 complete analyses of different types of water, and 12 of ooze, were made. The water passing through the Elbe at Tetschen proved to be 9,903,510,660 cubic metres during the year October 15, 1876, to October 15, 1877, which contained 776,309,959 kilograms of suspended or dissolved matter. During the year 1877, the amount of water run was 9,456,939,810 cubic metres, which contained 36,557 metrical tons of K_2O , 69,631 tons of Na_2O , 266,081 tons of CaO , 48,915 tons of MgO , 120,553 tons of SO_3 , 83,336 tons of chlorine, 778 tons of ammonia, and 11,196 of nitric acid. As to the sources of these immense quantities of mineral substances, Dr. Ullik points out that the amount which is supplied by waste water of manufactures and sewage is usually over-rated. Thus, if the well-known sulphuric acid manufacture at Aussig would pour all the acid it produces into the Elbe, it would give only 5000 tons of SO_3 per year, that is, only the 24th part of sulphuric acid anhydride contained in the waters of the river. The amount of mineral substance poured into the river by all the breweries of Bohemia would give only 401 tons per year, that is, the 1562nd part of all the minerals contained in the Elbe water. And, if all mineral substance contained in the sewage from the 5,000,000 inhabitants of Bohemia would reach the Elbe, it would yield only 33,250 tons, that is, 1-20th of what is really contained in the water of the river. Therefore, it is obvious that the chief source of these substances in the river-water must be sought for in the supply brought in by springs.—Dr. Siegmund Günther contributes to the same volume an interesting notice on the "Algorithmus Linealis," by Heinrich Strömer, which appeared in 1512, being one of the products of the revival of taste for mathematics which characterises, in Germany, the beginning of the sixteenth century. The same volume contains an elaborate paper on the Christian Calendar and on the methods of improving it, by Dr. W. Matzka; and a notice on the electrical clock of Rebeck, by Dr. A. Waltenhofen. It is worthy of notice that all papers that appear in the *Abhandlungen* are written in German, and are sold by the Society as separate pamphlets.

The *Sitzungsberichte*, or Proceedings, contain such a mass of valuable papers that we can notice only the more important of them. They are especially rich in mathematics, and we find (in the volume for the year 1879) papers by Dr. S. Günther, on the application of orthogonal co-ordinates to one problem of the potential theory; on the normals to parabole, by Dr. K.

Zahradnik; a very interesting paper by Prof. Carl Pelz, on the construction of radii of curvature of conic sections, all considered as mere corollaries of one theorem of Steiner; and several papers, by Dr. Franz Studnicka, concerning the theory of determinants and polynomials; and by Prof. J. Solin, on graphical integration; and Prof. A. Safarik contributes a paper giving the results of his observations on the Transit of Mercury on May 6, 1878. After having compared the photographs of the sun during the years 1875 to 1878, with observations on storms at Greenwich, Prague, and Vienna, Prof. Zenger arrived, as is known, at the conclusion that the 12.6 days' periodicity of "storms" on the surface of the sun had the effect of producing the same periodicity in the appearance of tornadoes in the West Indian and of typhoons in the Indo-Chinese Seas. Now, he discusses the storms noticed at Windsor (Australia) during the years 1863-75, and discovers in their appearance the same periodicity; the average deviations from it for the 29 duodecades of each year, being mostly but fractions of one day. But it must be observed that, for calculating the average error of these deviations, Prof. Zenger not only does not make use of the methods of least squares, but takes into account the signs, positive or negative, of the deviations, which method considerably diminishes the errors. Discussing Quetelet's tables of falls of meteorites, he arrives at the conclusion that these last also show the same periodicity. An elaborate paper, by Prof. Augustin, gives the results of thirty-eight year's observations of temperature at Prag, the averages being: winter, $-0^{\circ}.56$ Cels.; spring, $8^{\circ}.77$; summer, $19^{\circ}.01$; autumn, $9^{\circ}.60$; year, $9^{\circ}.18$.

Several communications are devoted to mineralogy, and we notice among them the papers of Prof. Krejci on the crystallisation of quartz, and on the homœomorphism of Sphalerite, Wurtzite, and Greenokit; on transformation-symbols, by Dr. N. Daubrawa; and on minerals from the Kuchelbad diabase, by MM. Preis and Urba. The papers on palæontology, geology, zoology, and botany, mostly deal with the fauna and flora, fossil or existing, of Bohemia itself. Dr. Ant. Fric gives a list of all fossil animals found in the coal and limestone of the Permian formation in Bohemia; whilst only two species were known from this formation in 1868, M. Fric's list includes no less than 87 species, mostly labyrinthodonts and fishes. Dr. O. Novak publishes his researches on hypostoms of trilobites; and Dr. O. Freismantel contributes three papers: on Nöggerathias of the Bohemian coal-fields; notices on the *Nöggerathia*, Stbg., *Nöggerathiopsis*, Fstm., and *Rhiptonanistes*, Schmalh., and the description of a new Calamaria, *Discinities bohemicus*. M. K. Taranek gives a description of Diatomaceæ from Bohemian marshes; Dr. J. Schöbl publishes the results of his researches on the reproduction of Isopod crustaceans; and Dr. Ullik, the results of several analyses of Bohemian waters. In the Ethnographical Department we notice a paper by Dr. Jirecek, on Walachians and Mauro-Walachians, according to documents found at Ragusa.

The next volume of the *Sitzungsberichte*, for the year 1880, is as rich as the preceding one. Dr. F. Studnicka continues his researches on the theory of determinants, and describes a new property of them, already observed by M. Catalan; and M. F. Mertens gives a new geometrical application of the rule of multiplication of determinants. Dr. A. Seydler studies the movement of a point on a given curves and superficies. In the domain of physics we notice but one paper, by Dr. K. Domalip, on the alternating discharges of electricity in rarefied space, in which paper the author deals especially with luminous back-currents. The researches of Prof. W. Zenger on the 12.6 days' periodicity, are continued in this volume. He remarks that this period is equal to one-half of the duration of each rotation of the sun, and tries to prove that the earthquakes in Southern Italy, from 1349 to 1873, as given by Prof. Suess, also fell on such days as closely coincide with the 12.6 days' period. He discovers the influence of the same periodicity in the dates of the passage of comets, from A.D. 371 to 1864, through their perihelium, as well as in the dates of meteoric showers. In further papers he tries to establish that the same periodicity might be discovered as to the maxima and minima of atmospheric pressure, of temperature, &c., and of magnetic disturbances. Finally, he shows that the sidereal durations of the revolutions of all planets are but multiples of the half rotation of the sun, and he finds that the same number appears also in the lengths of the months of the moon and of the satellites of Jupiter, Saturn, and Uranus. He concludes that "the cause of the movements in our solar system must be sought for in the

rotation of the sun," and that all phenomena of gravitation, magnetism, and electricity are but modifications of the same cause which occasions the rotation of the sun. Dr. F. Augustin contributes a paper on the climate of Prag, being a *résumé* of the meteorological observations made since 1840, and another paper on the influence of clouds on the diurnal march of temperature at Prag. Among geological papers we notice: the communication by Dr. Fric on the discovery of fossil remains of a bird, *Cretornis Hlavaci*, in the chalk of Bohemia ("Iser-schichten"); the description of a new Tertiary Batrachian, *Palæobatrachus bohemicus* (H. v. Meyer), from the brown coal at Böhmisch-Kamnitz, very similar to the *Palæobatrachus Goldfussi*, but different from it in the structure of several parts of the skeleton. M. Carl Heilmantel contributes two papers on the fossil flora of the Hangend-ridge of the Kladno-Rakonitz coal-basin, characterised by the abundance of *Filices*, *Aldopteris Serii*, and *Cyatheites arborescens*, being most common, and appearing in masses, whilst the *Sphenopteris* is scarcely represented, the *Neuropteris*, so characteristic of the lower deposits, completely disappears, and the *Lepidodendrons* become very rare. The group of *Leiodermaria* becomes, on the contrary, most usual, and acquires a new representative in the Permian *Sigillaria denudata*, Göpp., whilst Conifers become more numerous. The flora acquires thus a decidedly Permian character. Mr. J. Woldrich contributes a paper on the diluvial fauna at Sudslavic, close by Vimperk; it bears a decidedly northern character, as it contained remains of *Myodes torquatus*, *Nyctea nivea*, *Leucocyon lagopus*, *Felicius Erminea*, *Lepus variabilis*, *Arvicola nivalis*, *A. gregalis*, *Lagopus alpinus*, &c. Prof. A. Belohoubek gives an interesting sketch of the influence of geological structure on the chemical composition of water in very many springs and wells from different geological formations: old gneisses, Huron, Silurian, Carboniferous, Permian, Chalk, Tertiary, and Diluvium in Bohemia. The best water, as far as can be concluded from M. Belohoubek's researches, which he considers himself as only preliminary—is given by the Gneiss, Permian, and partly also by the Chalk; the worst, by the Carboniferous and Silurian. Dr. Vajdovsky gives a list of Rhizopods inhabiting the wells at Prag, several species of *Amaba*, *Centropyxix*, *Euglypha*, *Trinema*, &c., being characteristic for special wells. M. Taranek gives a description of Diatomaceæ at Warnsdorf. Prof. J. Dedecek gives a sketch of Bohemian Polytrichaceæ, and deals in another paper with the distribution of Hepatic mosses in Bohemia.

In the *Annual Reports* we notice, besides the public lectures read at the annual meetings, a most useful, complete bibliographical indexes of works and papers published by different members of the Society since the beginning of their scientific careers.

UNIVERSITY AND EDUCATIONAL INTELLIGENCE

CAMBRIDGE.—From the annual report on the local lectures in populous centres, we learn that 12 out of 23 courses of lectures in the Michaelmas Term of 1881, and 10 out of 20 courses in the Lent term of 1882, were on scientific subjects, and were delivered to audiences amounting in all to 1042 persons in the former term and 645 in the latter. This refers only to the work exclusively conducted from Cambridge, without including the courses of lectures in London and in the counties of Durham and Northumberland, which are also largely under the influence of the Cambridge system.

University College, Nottingham, has applied to be affiliated to Cambridge.

A further report of no progress has been made by the Sedgwick Museum Syndicate. It is estimated that 14,716l. is the present value of the investments and balances of the Memorial Fund. All that can be said as to the prospects of building is that further acquisitions of sites near the new museums make satisfactory proposals more possible. Prof. Hughes has addressed a letter to the Vice-Chancellor showing that a considerable proportion of the funds for building the present Woodwardian Museum and Library was sought and given expressly for a geological museum, so that the University may fairly be expected to find 15,000l. as the value of the present museum if it takes possession of it for the use of the Library.

The first part of the Natural Sciences Tripos has placed 24 men in the first class, 20 in the second, and 10 in the third, while

7 receive an ordinary degree, and 5 are excused the general examination. Six lady students are formally classed, the three in the first class being Girton students. Thus we have the unprecedented total of 72 names in one tripos list in natural science at Cambridge. Of those in the first class, Trinity and Christ's Colleges furnish 6 each, St. John's 5, Caius and King's 2 each, and Emmanuel and Clare and the non-collegiate students one each.

UNIVERSITY COLLEGE, LONDON.—Mr. L. F. Vernon-Harcourt, M.Inst.C.E., has been appointed Professor of Civil Engineering and Surveying. Mr. Kennedy retains the Professorship of Engineering and Mechanical Technology.

SCIENTIFIC SERIALS

Annalen der Physik und Chemie, No. 5.—On the relations between galvanic polarisation and the surface-tension of mercury, by A. Koenig.—On the work of external forces furnished in a closed circuit, by R. Colley.—On galvanic polarisation, and on the Smee element, by W. Hallock.—Theory of circulatory and elliptically-polarising media, by E. Ketteler.—On the change of the colour-tone of spectral colours and pigments with decreasing intensity of light, by E. Albert.—On the influence of deformation on electric conductivity, by A. Witkowski.—Researches on the height of the atmosphere and the constitution of gaseous heavenly bodies, by A. Ritter.

Journal de Physique, May.—Electro-chemical figuration of equipotential lines on any portions of a plane, by A. Guébbard.—Note on the tangent-compass, by M. Mascart.—Variation of the coefficient of viscosity with the velocity, by B. Elie.—Apparatus for showing and measuring in projection, and simultaneously, the plane of polarisation of the analyser and of the crystalline plate, by L. Laurent.—Register of the duration of rain, by M. Schmeltz.

Bulletin de l'Académie des Sciences de St. Pétersbourg (vol. xxviii. fasc. 1).—Analysis of samples of water from lakes and sources in Tibet, by Dr. C. Schmidt.—Measurements of crystals of Datolith, Amphibol, and Vanguelin, by B. Koksharov.—On the necessary degree of sensibility of magnetic variation instruments, by H. Wild.—Galvanic phenomena in the cerebro-spinal axis of the frog, by J. Setschenow.—Remarks on the Amphishænidæ, by Dr. A. Strauch.—New researches on the hypothesis of a resisting medium, by O. Backlund.—Effects of the tension on the electrical resistance of copper-wires, by O. Chwolson.

WE notice in the last number of the "Journal of the Russian Chemical Society" (vol. xiv. fasc. 4), an interesting paper by M. Radoulowitch, on the formation of peroxide of hydrogen during the oxidation of the terpenes, in which he tries to establish, contrary to the opinions of MM. Berthelot and Pappasogli, that the oxidation processes manifested by the turpentine oil are not due to the presence of oxygenated compounds of nitrogen, but to the presence of peroxide of hydrogen. In the same number of the "Journal" Prof. Menshutkin gives a summary of his extensive work on the formation of ethers. M. Schwedoff contributes a paper in which he refutes the opinions as to the tails of comets being the result of the repulsive force of the sun on the matter of the comets, and especially the conclusions arrived at by Prof. Bredikhin on the subject; and M. Jouk publishes numerical results as to the temperatures of boiling of methyl alcohol and amylene.

SOCIETIES AND ACADEMIES

LONDON

Mathematical Society, June 8.—S. Roberts, F.R.S., president, in the chair.—Messrs. J. W. Berry, A. R. Forsyth, and J. Wood were elected Members, and Mr. R. A. Roberts was admitted into the Society.—The following communications were made:—On the extension of certain theories relating to plane cubics to curves of any deficiency, A. Buchheim [the object of the paper was the extension, by the use of Abelian functions, of certain theories which, in the case of plane cubics, are immediate consequences of the representation of the co-ordinates of a point of the curve as elliptic functions of a parameter. The theories considered were: (1) the theory of Steiner's polygons, and (2) Prof. Sylvester's theory of derived points (cf. Clifford's "Classification of Loci")].—On the differentiation with respect

to the modulus of the amplitude of elliptic functions, Rev. M. M. U. Wilkinson.—Two notes: (1) a definite integral; (2) equation of the director circle of a conic, Prof. Wolstenholme [(2) got, in the case of oblique cartesian co-ordinates, in the form $\frac{d^2u^2}{dx^2} + \frac{d^2u^2}{dy^2} = 2 \frac{d^2u^2}{du^2} \cos \omega$].—Theory of orthoptic loci, Rev. Dr. Taylor [the orthoptic locus of any curve is the locus of intersection of tangents at right angles].

Linnean Society, June 1.—Frank Crisp, LL.B., treasurer, in the chair.—Mr. H. C. Burdett was elected a Fellow of the Society.—Mr. H. N. Ridley drew attention to an *Equisetum maximum* from Swanage, having a spike of fructification surmounted by a branch-bearing portion, and remarkable on account of the transition of the sporophores along with the brown acuminate leaves.—The Rev. G. Henslow exhibited malformed specimens of wallflower, of rhododendron, and of the Garden Ranunculus.—Mr. Marshall Ward read a paper on his researches on the life history of *Hemileia vastatrix*, the fungus of the coffee-leaf disease. The phenomena attendant thereon shows great analogy to those of the Uredine fungi. The spores, under favourable conditions, viz., moisture, a due supply of oxygen, and a temperature of 75° F., usually germinate in from twelve to twenty-four hours.—Complete infection or establishment of the mycelium in the intercellular passages of the leaf occurs about the third day after the formation of the germinal tubes. The so-called yellow spot or ordinary outward visible appearance of the disease manifests itself about the fourteenth or fifteenth day, but may be delayed; its development and course being dependent on secondary causes, such as atmospheric conditions, monsoons, age of the coffee-leaf, &c. By watching the progress of the spots it has been ascertained that the spores therefrom may be continuously produced for from seven to eleven weeks or even more. Some 150,000 spores have been estimated as present in one yellow cluster spot, and as 127 disease spots have been counted in one pair of leaves, the quantity of spores thus regularly produced must be enormous. According to the amount of diseased spots, the sooner the leaf falls; and though young leaves arise, the fruit-bearing qualities of the plant necessarily are seriously interfered with. The various sorts of coffee plant are all liable to infection; the only possible remedy is the difficult one of destruction of the spores, and these are supposed originally to have been introduced from the native jungle, and rapidly spread under the favourable conditions of artificial cultivation.—Dr. Hoggan read a paper on some cutaneous nerve-terminations in mammals. He related observations on the habits of the mole (*Talpa*), with reference to its nasal organ, as a special sense of touch, and of the tail as a tactile organ. The so-called "Organ of Eimer" in the mole's nose, its fibres and cells, are similar in character to the ordinary sub-epidermic nerve-cells and their intradermic fibrillar prolongations. There is a probability that the inner circle of fibrils possesses the power of touch, and that the centre ones and those of the outer circle provide the sense of temperature, pain, and other sympathetic functions. The Paccinian bodies at the root of the organ probably register pressure.—Mr. C. B. Clarke read a paper on two Himalayan ferns erroneously described in the ferns of British India.—A communication was made on the Ascidiæ collected in the cruise of the yacht *Glimpse* in 1881, by Mr. H. C. Sorby and Prof. W. A. Herdman. Twelve species were noted, one *Molgula capiformis*, from near Poole, being new.—Mr. P. H. Carpenter followed by descriptions of new or little-known Comatulæ, being material derived from the *Challenger* expedition and Hamburg Museum. The author institutes the new genus *Eudiorcinus* for Semper's *Ophiocrinus*.—Two other papers read were:—Notes on recent additions to the New Zealand flora, by Mr. Thos. Kirk, and descriptions of four new species of *Donax*, by Mr. Sylvanus Hanley.

Physical Society, June 10.—Prof. Clifton, pre-ident, in the chair.—New member, Major-General Martin, R.E.—Mr. W. F. Stanley read a paper on sonorous vibrations, especially those of the tuning-fork. The larger and more visible movements of a sounding-body do not appear to be best fitted to propagate musical-sounds as was shown by placing disks on the prongs of a powerful fork, which, when vibrating, could then only be heard a short distance, whereas, by its smaller longitudinal motions, when placed on its resonator, it produced a penetrating sound. The vibration down the stem of the fork was shown not to depend upon a vibrating ventroid, as suggested by Chladni, for a fork cut in the end of a solid steel bar communicated sonorous vibrations equally well to the resonator. To set a fork in vibration it was necessary to

bow one prong only, therefore, in this case, the vibration must proceed along the prongs. A light fork 1 metre long was fixed in a heavy vice, and it was shown by it that vibrations passed down one prong and up the other alternately. By means of dust, ripples were shown to run down an ordinary fork in vibration. Light pieces of metal were fitted to the ends of a powerful fork, and these immersed in mercury, the reflected surface of which was shown on a screen, where it was seen that the whole mercury surface was broken into fine ripples. It was suggested that such small waves are also perceived by the ear. By these, certain conditions of harmonics could be better accounted for, as, for example, by division in smaller waves, the rarefaction of a note in space would not suffer interference by the condensation of its octave falling in the same space and time.—Lord Rayleigh explained several of Mr. Stanley's experiments on the known theory of sound.—Mr. Walter Bailey then exhibited a model of a new "integrating anemometer." This apparatus contains a horizontal plane, in which are two slits forming a cross with arms towards the cardinal points. Each slit is fitted with a sliding-piece, and the two slides are connected by a bar; the arrangement being that of the well-known instrument for drawing ellipses. The slides carry beneath them wheels with their planes perpendicular to the slits, and passing through the pivots of the bar. The wheels rest on a horizontal disk, whose centre is beneath the centre of the cross. The centre of the bar is to be connected to a weathercock which will keep it in the direction of the wind when looked at from the centre of the instrument. The disk is to be revolved by Robinson's cups. The number of revolutions of the wheels then give the integral of the resolved parts of the wind in the direction of the cardinal points. In the working model of the instrument exhibited there was an electrical arrangement connected with four indicators, one for each of the cardinal points. At each turn of a wheel a circuit was completed, and the corresponding indicator moved. Recording instruments are to be substituted for indicators, and the amount recorded on each in a given time will be proportional to the total motion of the wind towards the corresponding cardinal point.—Mr. Lecky pointed out that a good anemometer was a great desideratum at present.—The Society meets at Oxford on the 17th, and South Kensington on the 24th of this month.

Anthropological Institute, May 23.—General Pitt-Rivers, F.R.S., president, in the chair.—A paper was read by the Right Hon. Sir H. Bartle Frere, Bart., on systems of land tenure among aboriginal tribes of South Africa." The author indicated the points regarding which further inquiry is needed, and urged the importance of recording observations whilst it is still possible to obtain information from sources which in the course of another generation may be closed for ever by the extinction of races. The Zulu title to the lands in South Africa rests simply on force, the land being his property only so long as the occupant can hold it by himself, or with the assistance of the chief who protects him. The tenure cannot be transmitted by inheritance without being constantly sapped by the influence of two institutions universal among the Zulus, viz., polygamy and slavery. Christianity has a special bearing on the subject of land tenure, because it is mainly through its agency, indirect as well as direct, that we may look for such changes in the customs of the races of South Africa as may civilise and settle them, and put an end to the ceaseless wanderings which have tended so powerfully to keep them in a state of ever-recurring barbarism. The author's impression was that the advancement and civilisation of the native tribes of South Africa depend greatly upon the extent to which individual tenure of property can be extended, whilst some patriarchal authority such as seems inherent in the head of a family or kraal is recognised, and invested with some sort of magisterial and judicial functions, sufficient to meet the everyday exigencies of village life. The President opened the discussion with some remarks on the peculiarities of land tenure in various parts of the world, and was followed by Dr. Rae, Mr. Hyde Clarke, and Miss Buckland.—On the motion of Prof. Flower, a cordial vote of thanks was given to the president and Mrs. Pitt-Rivers for their kindness in allowing the meeting to be held at their house.

EDINBURGH

Royal Society, June 5.—The Right Hon. Lord Moncrieff, president, in the chair.—Obituary notices of Dr. Lauder Lindsay, Mr. David Smith, and Prof. Peirce of Harvard, were read.—The Council announced the award of the Keith Prize for the

Biennial Period 1879-81, to Prof. Chrystal, for his paper on the differential telephone, which is published in the Society's *Transactions* (1879-80), and gives a new, simple, and accurate method of measuring capacities and co-efficients of mutual and self-induction (see *NATURE*, vol. xxii. p. 331); and of the Neill prize, for the triennial period 1877-80, to Mr. John Murray, for his paper on the structure and origin of coral reefs and islands, communicated to the Society on April 5, 1880, and printed (in abstract) in the *Proceedings* of that date (see *NATURE*, vol. xxii. p. 351).—Prof. Tait communicated Part II. of his paper on mirage. Having formerly shown that the observed phenomena could be explained in a general way by assuming a certain relation to exist between the refractive index of the air at any point, and its situation between two planes of approximately stationary density; the author, in his second paper, proceeded to investigate the conditions more carefully, so as to find, if possible, a distribution of atmospheric density which should be at once probable, and produce mirage phenomena the same in all important particulars as those observed by Scoresby, Vince, and others, and at the same time be capable of easy mathematical treatment. Two horizontal strata of uniform but different densities, separated by a stratum whose density varies continuously from the one to the other, were found to give results in close agreement with observation. That a stratum of air should remain of practically uniform density through even a comparatively small height requires a lowering of temperature to compensate for the diminution of pressure as the height increases; but this rate of change of temperature Prof. Tait showed was not greater than had been observed in balloon ascents. With given thicknesses of strata, there was a critical minimum distance at which mirage could be obtained. For greater distances there were three images, two direct and one inverted. The inverted one was always larger than the lower direct one, but only appreciably so when the distance of the object approached this critical minimum value, for which the phenomenon known as "looming" became evident. The second direct image is usually much the smallest, being, except at distances near this same critical distance, so small as to be practically invisible. This seems fully to account for the comparatively few instances in which the three images have been observed. Multiple inverted images, as observed by Scoresby, were explained as due to thin successive layers of varying density at different heights. It was shown that Wollaston's illustrative experiment, in which three images are produced, is *not* quite analogous to the state of affairs which produce them naturally. In order to make it so, the tank must be greatly increased in length, and the difference of density of the inter-diffusing fluids greatly diminished; so that the rays may enter and leave the transition stratum by its lower side, and *not* by its ends. The rest of the paper showed how Wollaston's arrangement could be simply and accurately applied to measurement of rates of diffusion.—Mr. Milne Home communicated the Eighth Report of the Boulder Committee. This dealt mainly with the boulders around Ben Nevis, which had been examined by Prof. Heddle, Prof. Duns, and Mr. Livingston of Fort William.

BERLIN

Physical Society, May 26.—Prof. du Bois-Reymond in the chair.—Prof. Landolt showed a new polarisation-apparatus, whose polarising part is formed according to the method of M. Cornu, modified by Herr Lippich, and which has this advantage over others, especially, that it is not mounted on a foot, but on a solid base, whereby bending and torsion of the tube which holds the liquid are avoided. This tube is inclosed in a cylindrical envelope, in which water of any desired temperature can circulate. By a simple lever movement, the tube filled with the experimental liquid can at any time be directly replaced by an empty tube, and conversely; so that the zero point can be controlled as often as desired. In its present form, the apparatus is pretty perfect for scientific researches; further improvement must be directed principally to the production of a good light-source. Some proposed alterations of the apparatus, now in hand, will afford the opportunity of examining vapours in reference to their rotatory power.—Dr. Hagen reported on experiments for measuring the vapour-tension of mercury at different temperatures. He first indicated briefly the apparatus Regnault used, and the results obtained with it, by that physicist. The values given by Regnault are met with in all text-books of physics; yet they differ very considerably from the amounts found by Regnault in his experiments, and these do not agree together. The author, therefore, undertook a new determina-

tion of these values. The apparatus consisted of a U-shaped tube, having at the lower part a long straight tube, united to it by fusion, while above, either branch terminated in a tube twice bent at a right angle, and closed at the lower end. By means of a Hagen air-pump this tube-system was gradually evacuated to a pressure of 1-12,000,000 mm. mercury, and the long straight tube opened under mercury at the lower end. The mercury rose in both branches of the U-tube to barometric height. One of the lateral ends of the apparatus was now kept constant at 0°; while the other was first cooled to -42°, and then heated to various temperatures; each time the position of the mercury in the two branches was observed with a cathetometer, and the difference of their heights gave the vapour-tension. The values so obtained for the vapour-tension of mercury were less for all temperatures than those given by Regnault. Thus, e.g. Herr Hagen found the tension at 0° = 0.015 mm., Regnault 0.02; at 20°, Hagen 0.021, Regnault 0.037; at 100°, Hagen 0.61, Regnault 0.75; at 200°, Hagen 16, Regnault 19.9 mm. Though the values now found have no claim to absolute accuracy (owing to the difficulty of taking readings with the cathetometer, through round glass), these experiments at least make certain that the Regnault values for the vapour-tension of mercury, which have passed into all text-books, are considerably too large.

PARIS

Academy of Sciences, June 5.—M. Jamin in the chair.—The following papers were read:—On double salts prepared by fusion, by MM. Berthelot and Ilosvay.—Report on the expedition to Cape Horn, by H. Milne-Edwards. This meteorological mission, to start soon, for a year's sojourn at Cape Horn, will have two medical men, Drs. Hyades and Han, who have undertaken to collect and make observations as the Academy may indicate. A Committee of the Academy has urged the Government to add a preparer of collections, and nominated M. Sauvinet for this post; total additional cost 3625 fr. The wish is expressed that specialists in zoology, botany, and geology could have been appointed; but the resources did not allow of this.—Zoological instructions drawn up for the members of the Cape Horn Mission by M. Alph. Milne-Edwards. Special attention should be given to the large mammalia—seals, sea-elephants, otaries, cachalots, &c., some of which are rapidly disappearing. Various penguins and other sea-birds call for study; the fishes are imperfectly known, and a good harvest from dredging operations may be looked for.—The true puceron of the vine (*Aphis vitis*, Scopoli), by M. Lichtenstein.—History of standards of the metre, by M. Wolf.—On the waves produced by the emersion of a solid at the surface of a quiet wave, when there is occasion to take account of two horizontal co-ordinates, by M. Boussinesq.—On the boiling-temperature of selenium, by M. Troost. Employing a method described March 29, 1880, he arrives at the figure 665° C. for pressure near 760 mm. It is shown that glasses of small fusibility, such as Bohemian and certain French glasses, may be kept at that temperature without deformation, and so used for long chemical reactions.—On a calorimeter dependent on cooling, by M. Violle. This is for use where the initial temperature is between 100° and 400° or 500°. It consists of a small, narrow-necked bottle of thin glass, with double envelope, and a vacuum produced in the interval before closure. Through the neck is introduced a thermometer and a stirrer.—Determination of the specific heats of small quantities of substances, by MM. Thonlet and Lagarde. The method is designed for pure mineral species (0.1 gr. to 0.5 gr.). Its principle is this: If two thermoelectric junctions be put in tubes holding a liquid of known specific heat (e.g. water, or oil of turpentine), one may measure, by the deflection in a galvanometer, the rise of temperature resulting from immersion in one of the tubes of a body raised to a known temperature, and compare it with that in a second experiment made with a typical body (e.g. copper). The method (which is illustrated by a figure) is shown to be exact.—On a new condensation-hygrometer, by M. Crova. A small tube of nickel-plated brass, carefully polished within, is closed at one end with ground glass, and at the other with a lens of long focus, through which one looks along the tube towards a light-source. Through two terminal tubulures, the air to be examined is drawn through the tube, which is cooled by means of sulphide of carbon traversed by an air current in a metallic envelope round the tube. The changes of aspect in the tube at the temperature of saturation, enable one to estimate the dew-point to one-tenth of a degree.—Law of freezing of

aqueous solutions of organic matters, by M. Raoult. The molecules of different organic matters, dissolved in the same quantity of water, cause sensibly the same retardation in its freezing-point.—Method for determination of the ohm, by M. Joubert.—Influence of the positive electrode of the battery on its chemical work, by M. Tommasi.—On oxychlorides of zinc, by M. André.—Action of sulphide of carbon on silicium, by M. Colson.—Preliminary note on didymium, by M. Clève. This points to the existence of a new element accompanying didymium. The author proposes to designate it provisionally by the symbol Diβ; it is characterised by the strong line $\lambda = 4335.5$.—On a new monochlorinated camphor, by M. Cazeneuve.—On spontaneous fermentations of animal matters, by M. Béchamp. He reviews past researches, and indicates a number of deductions from them.—MM. Cazeneuve and Daremburg called attention to the fact of proof having been given by them in 1874, that in general all the substances called *colloid* by Virchow and his school, strongly decompose oxygenated water.—On the nervetissue of the spinal cord, by M. Ranvier.—Experimental attempt at anatomical localisation of symptoms of toxic delirium in the dog, by M. Danillo.—Essence of absinthe was injected into dogs. The integrity of the optic thalami is not necessary for production of toxic delirium. The cortical region throughout is exclusively concerned.—M. Larroque furnished some data regarding the thunderstorm of May 30. In some regions there was torrential rain, in others hail.—On a new combination of the lenses of the microscope, by M. Zenger. With a great focal distance he obtains a magnification equal to 2000.

VIENNA

Imperial Academy of Sciences, May 11.—L. I. Fitzinger in the chair.—H. Hammerl, contributions to the knowledge of the formation of hydrates of salts.—P. Wesselsky and R. Benedikt, on some nitro-products from the pyrocatechin series.—F. Exner, determination of the ratio-electrostatic and electromagnetic absolute unit.—A. Tschinkel, communication on experiments relating to the action of electricity on the growth of plants.—F. Heger, continuation of the fifth report of the Pre-historic Commission on two excavations near Chotzen (Boh.) and near Hallein (Salzburg).—G. Bruder, contributions to a knowledge of the Jurassic deposits in Northern Bohemia.—E. Stefan, on the lines of force of a field symmetrical round an axis. May 25.—Anniversary Meeting.—E. v. Bruecke was elected vice-president in room of V. Burg.—In the Mathematical class, Theodor v. Oppolzer (Vienna), Julius Wiesner, and Emil Weyr Vienna, were elected Members.—Fr. E. Schultze (Gratz), V. v. Ebner (Gratz), M. Neumayr Vienna, L. v. Pebal (Gratz), H. Dürge (Prague) Correspondents, Friedrich Wohler (Göttingen) Honorary Member, L. Pasteur (Paris) G. G. Stokes (Cambridge) and T. Lovén (Stockholm) foreign correspondents.—The meeting was opened by the curator of the Academy, Archduke Rainer. The reports for the past year were read by the general secretary, Prof. Siegel and the secretary of the Mathematical Class, Prof. Stefan.—Then Prof. E. Much (Prague) gave an address on the economic nature of physical research.

CONTENTS

	PAGE
CHARLES DARWIN, IV.	145
MASCART AND JOUBERT'S "ELECTRICITY AND MAGNETISM"	147
OUR BOOK SHELF:—	
Hörnes and Auinger's "Fossil Gasteropods."—J. GWYN JEFFREYS, F.R.S.	149
LETTERS TO THE EDITOR:—	
The Winter of 1881-82.—Dr. A. WOEIKOF	150
The Mean Temperature of the Atmosphere at the Surface of the Earth as Determined by Observations and by Theory.—O. REICHENBACH	150
Sea-shore Alluvion—The "Chesil."—J. B. REDMAN	151
Meteor.—E. J. STONE, F.R.S.	151
Earthquakes in Naples.—H. J. JOHNSTON-LAVIS	151
THE "POLYPHEMUS"	151
DOUBLE STARS. By Dr. W. DOBERCK (<i>With Diagrams</i>)	153
THE MARIANNE NORTH GALLERY OF PAINTINGS OF "PLANTS AND THEIR HOMES," ROYAL GARDENS, KEW. By W. BOTTING HEMSLEY	155
AN ELECTRIC RAILWAY (<i>With Illustrations</i>)	156
THE WEATHER OF THE PAST WEEK	158
NOTES	158
OUR ASTRONOMICAL COLUMN:—	
Maskelyne's Value of the Solar Parallax	161
Meteor 1882a (Wells, March 17)	161
A Suspected Variable Star	162
The University Observatory, Oxford	162
GEOGRAPHICAL NOTES	162
A NEW THERMOGRAPH. By G. MORGAN ELDRIDGE (<i>With Diagrams</i>)	163
SCIENCE IN BOHEMIA	164
UNIVERSITY AND EDUCATIONAL INTELLIGENCE	165
SCIENTIFIC SERIALS	166
SOCIETIES AND ACADEMIES	166