

Biblioteka Główna i OINT
Politechniki Wrocławskiej

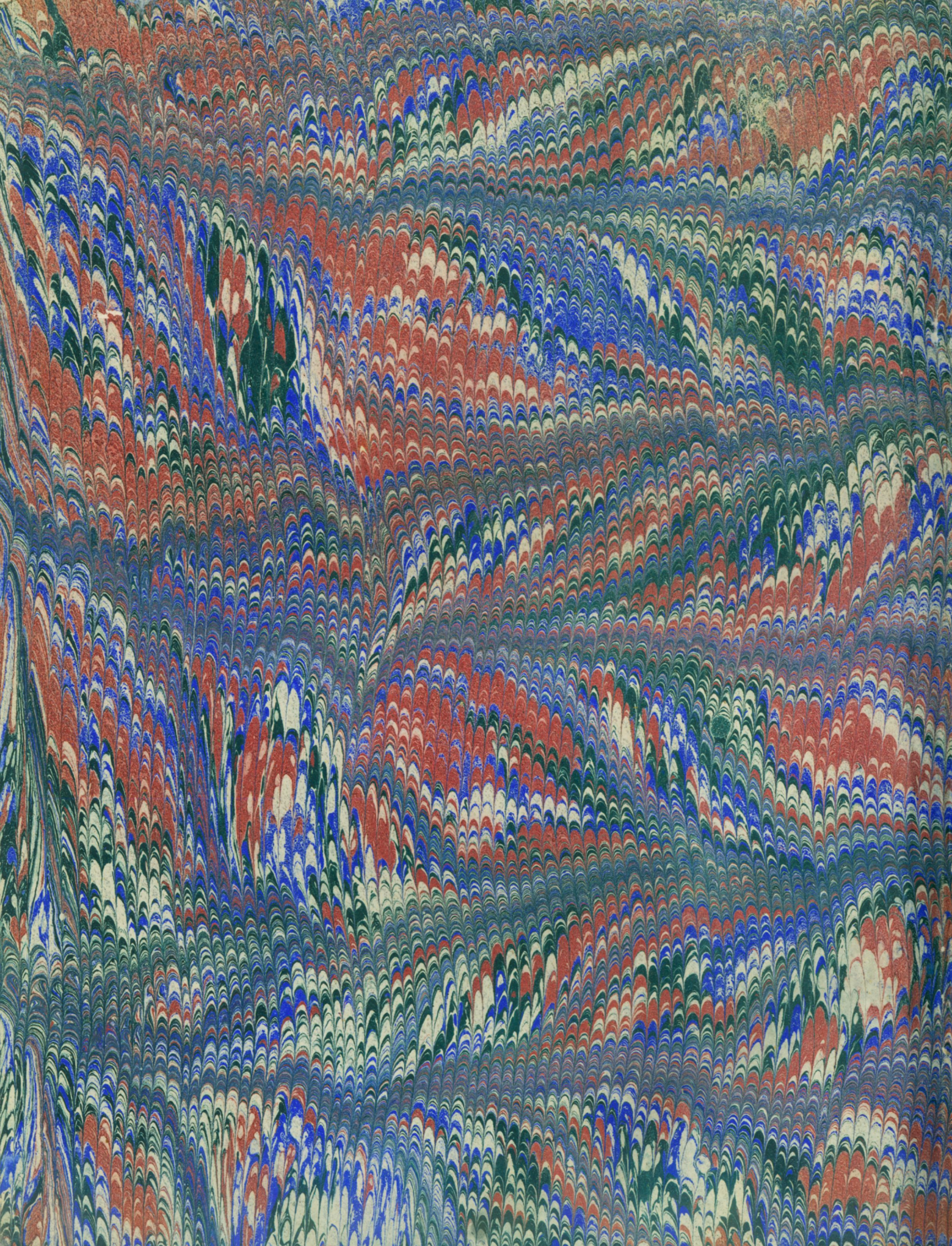

100100085958

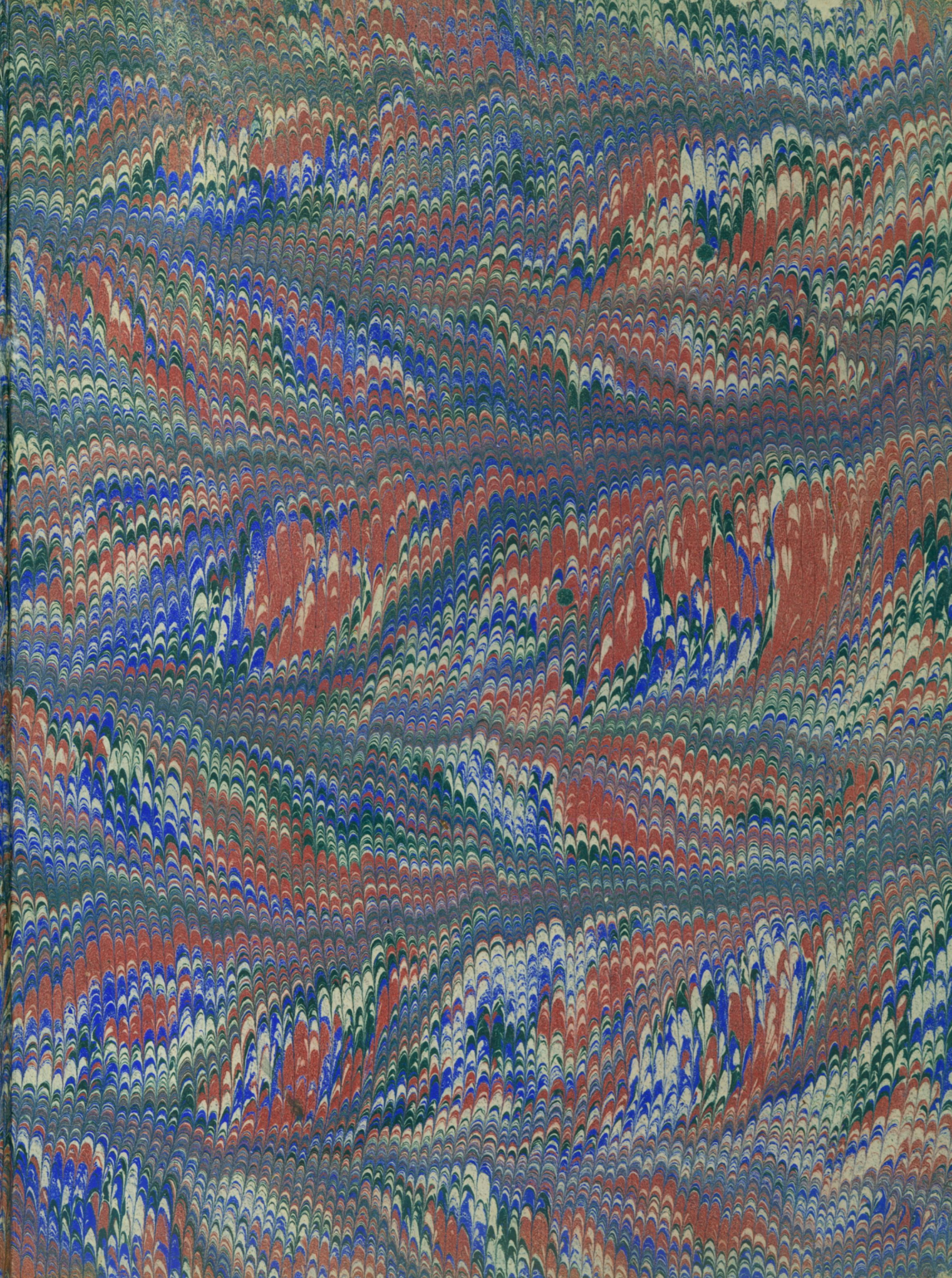



R96

m



PUBLICATION INDUSTRIELLE
DES
MACHINES, OUTILS ET APPAREILS

LES PLUS PERFECTIONNÉS ET LES PLUS RÉCENTS

EMPLOYÉS

DANS LES DIFFÉRENTES BRANCHES DE L'INDUSTRIE FRANÇAISE ET ÉTRANGÈRE

PAR

ARMENGAUD AINÉ

INGÉNIEUR, PROFESSEUR AU CONSERVATOIRE NATIONAL DES ARTS ET MÉTIERS
MEMBRE DE LA SOCIÉTÉ D'ENCOURAGEMENT ET DE LA SOCIÉTÉ INDUSTRIELLE DE MULHOUSE

TOME DEUXIÈME

TROISIÈME ÉDITION, REVUE ET CORRIGÉE.

—❦—
PLANCHES
—❦—

1912. 499.

PARIS

CHEZ L'AUTEUR, 45 RUE RUE SAINT-SÉBASTIEN

BOULEVART DES FILLES-DU-CALVAIRE

A LA LIBRAIRIE SCIENTIFIQUE-INDUSTRIELLE DE L. MATHIAS, 15, QUAI MALAQUAIS

—
1851

TABLE DES PLANCHES

DU TOME DEUXIÈME DE LA PUBLICATION INDUSTRIELLE

PLANCHES.	1 ^{re} LIVRAISON.	PAGES.	PLANCHES.	6 ^e LIVRAISON.	PAGES.		
1	Grande plate-forme pour tailler les engrenages, par M. CARTIER.	3	21	Machine à cinq cylindres pour écraser les cannes à sucre, par M. NILIUS, du Havre.	259		
2		61	22		Hache-paille et coupe-racines, par MM. MOTHEs.	275	
3		68	23			Machine à moirer et à gaufrer le papier, par M. KURTZ . . .	283
4		32	24				Pompes à eau pour bateaux à vapeur, par M. PAUWELS. . . .
2^e LIVRAISON.							
5	Machine à graver les cylindres d'impression, par M. HUGUENIN.	96	25	Tour à vitesses variables, avec support à chariot, par M. CARLIER	309		
6	Presse horizontale chauffée par la vapeur, par M. SAULNIER. . .	112	26				
7	Applications de la chaleur perdue des hauts-fourneaux, par MM. LAURENS et THOMAS, et par M. E. FLACHAT	123	27	Vis pneumatique, ventilateurs à ailes droites et à ailes courbes.	328		
8		134	28			Machine à mortaiser, aléser et raboter les métaux, par M. CAVÉ.	341
3^e LIVRAISON.							
9	Nouveau tour à chariot et à fileter, par M. WHITWORTH.	143	29	Suite de la machine à mortaiser, aléser et raboter les métaux, de M. CAVÉ.	343		
10	Machine à broyer les matières dures et sèches, par MM. BARATTE et BOUVET.	158	30				
11		169	31	Machines à faire les briques de MM. CARVILLE et CAPOUILLET.	356		
12	Appareil du navire à vapeur <i>le Vautour</i> , par M. GENGEMBRE. .	169	32	Petit martinet avec sa machine à vapeur, par M. MARIOTTE. . .	372		
4^e LIVRAISON.							
13	Suite de l'appareil du <i>Vautour</i> , par M. GENGEMBRE.	171	33	Machine à percer verticale, à plateau mobile, avec poulies à rotule, par M. DECOSTER.	385		
14	Appareil d'exhaustion appliqué audit, par le même	191	34				
15	Système de désembrayage, par M. MANGEON.	195	35	Nouvelles turbines hydrauliques, par MM. CALLON et CADIAT. . .	394		
16	Chaudière du navire à vapeur <i>le Tancredé</i>	199	36	Machine à fabriquer les clous d'épingle et les béquets, par M. FIANTZ.	410		
16	Machinè à vapeur pour bateau, par M. MAUDSLEY.	207					
5^e LIVRAISON.							
17	Machine à triturer les bois de teinture, par M. BERENDORF. . . .	229	37	Roues hydrauliques à augets, en fonte, et en fer.	425		
18	Machine à relever les molettes, par M. HUGUENIN.	237	38				
19	Machine à diviser les molettes, par M. HUGUENIN.	241	39	Pont en fonte, à direction biaise, établi sur le le canal de la Brusche, par M. CADIAT.	469		
20	Petite machine à raboter les métaux, par MM. MEYER.	247	40				
6^e LIVRAISON.							
7^e LIVRAISON.							
8^e LIVRAISON.							
9^e LIVRAISON.							
10^e LIVRAISON.							

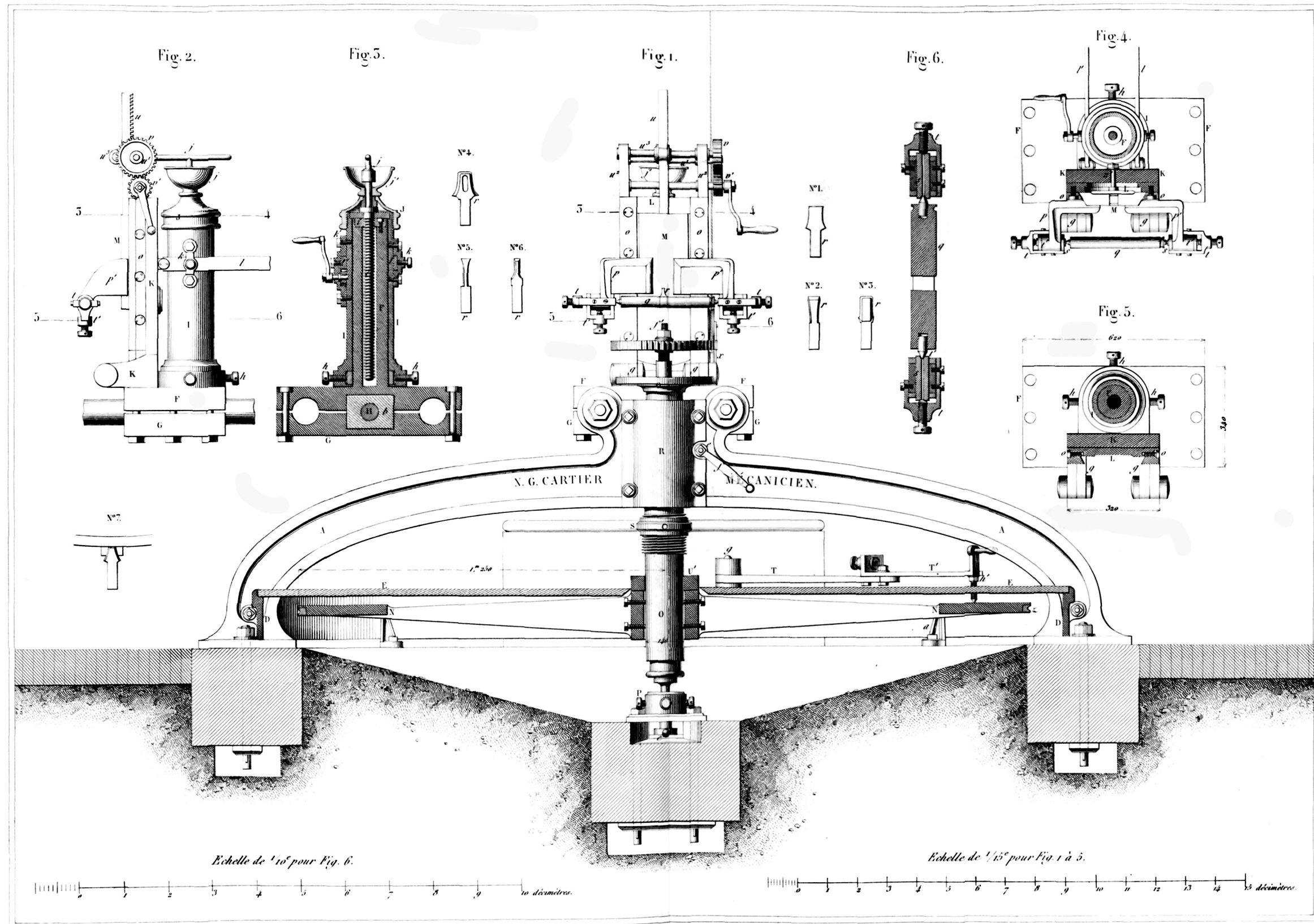

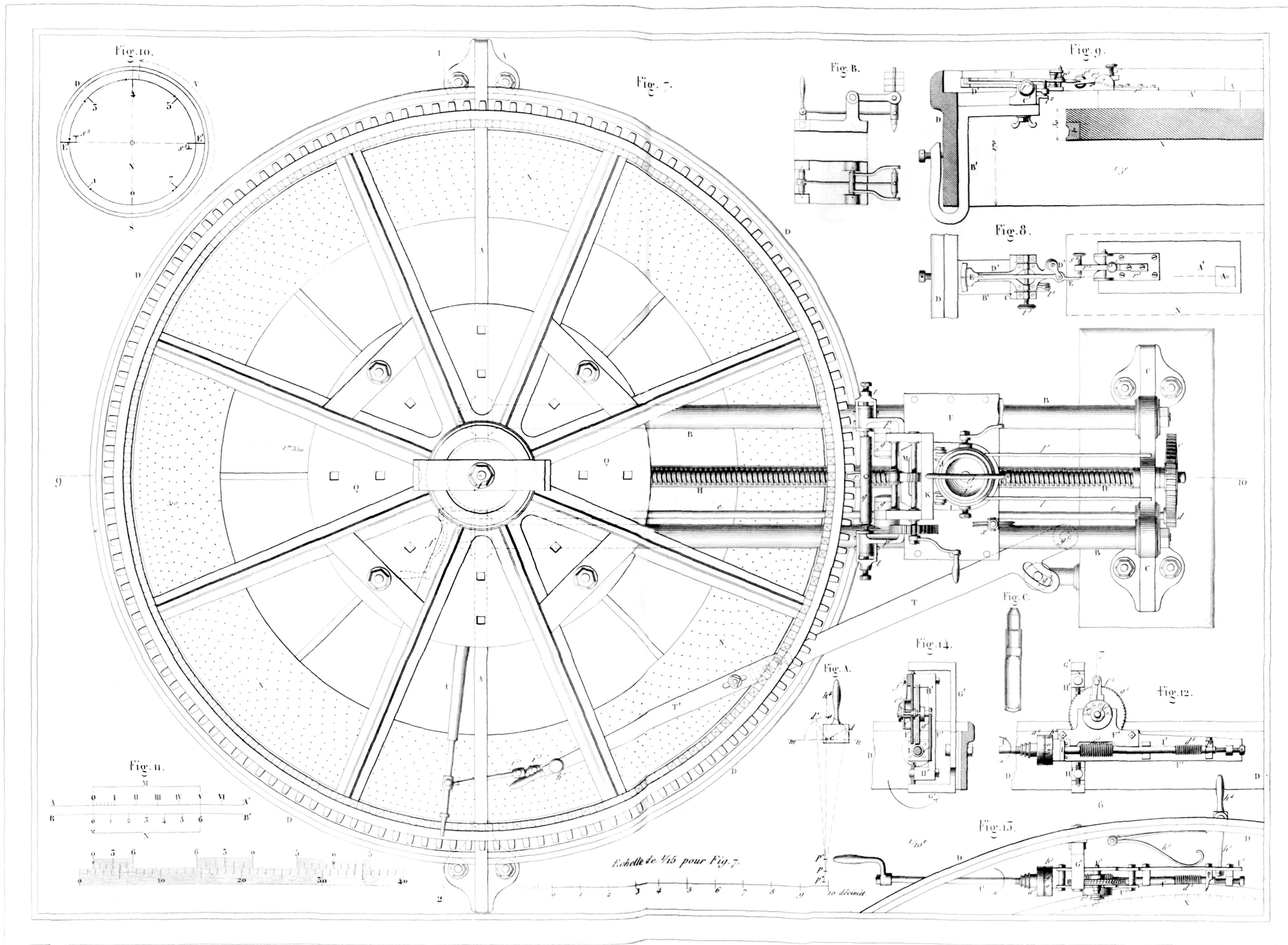

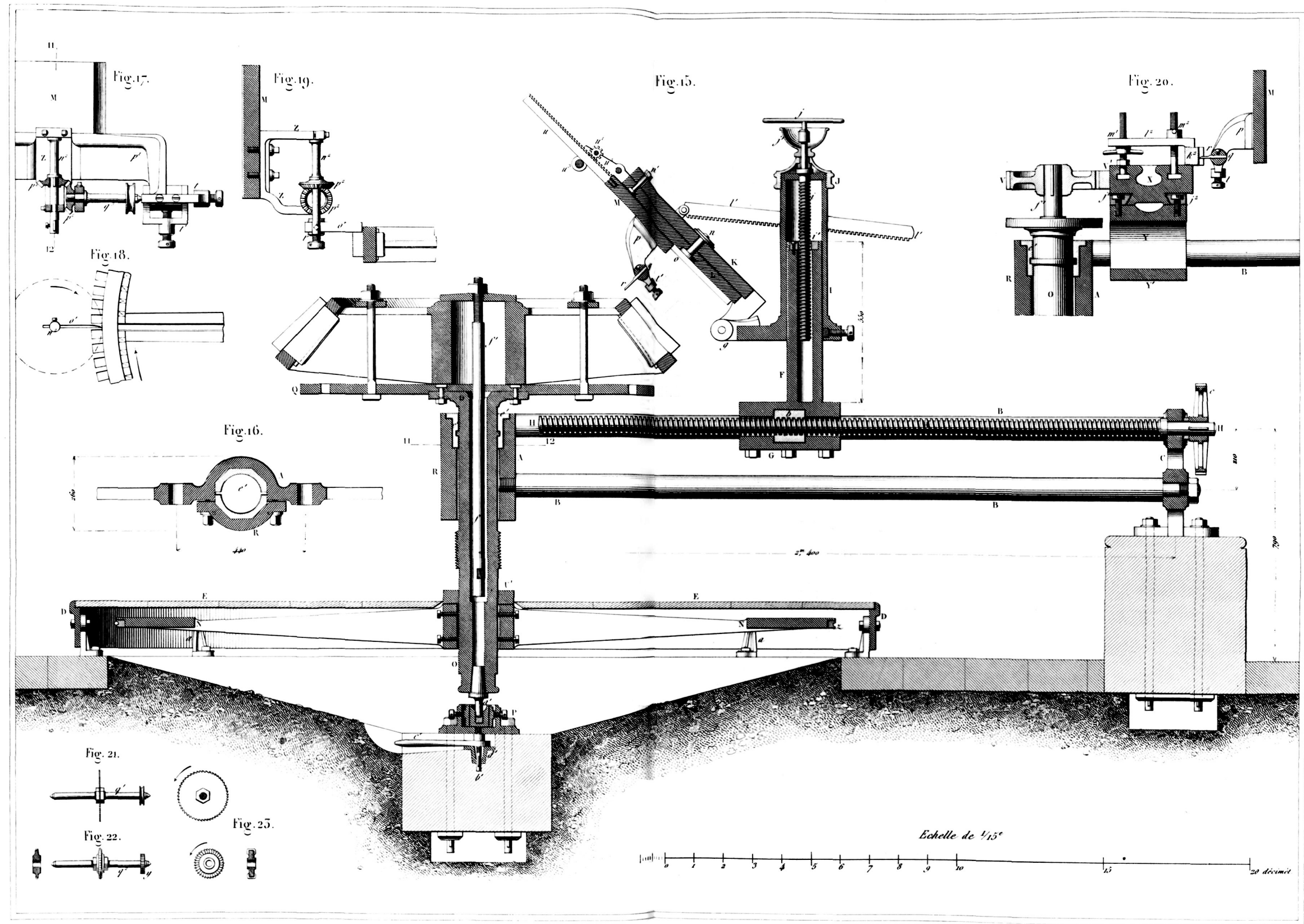

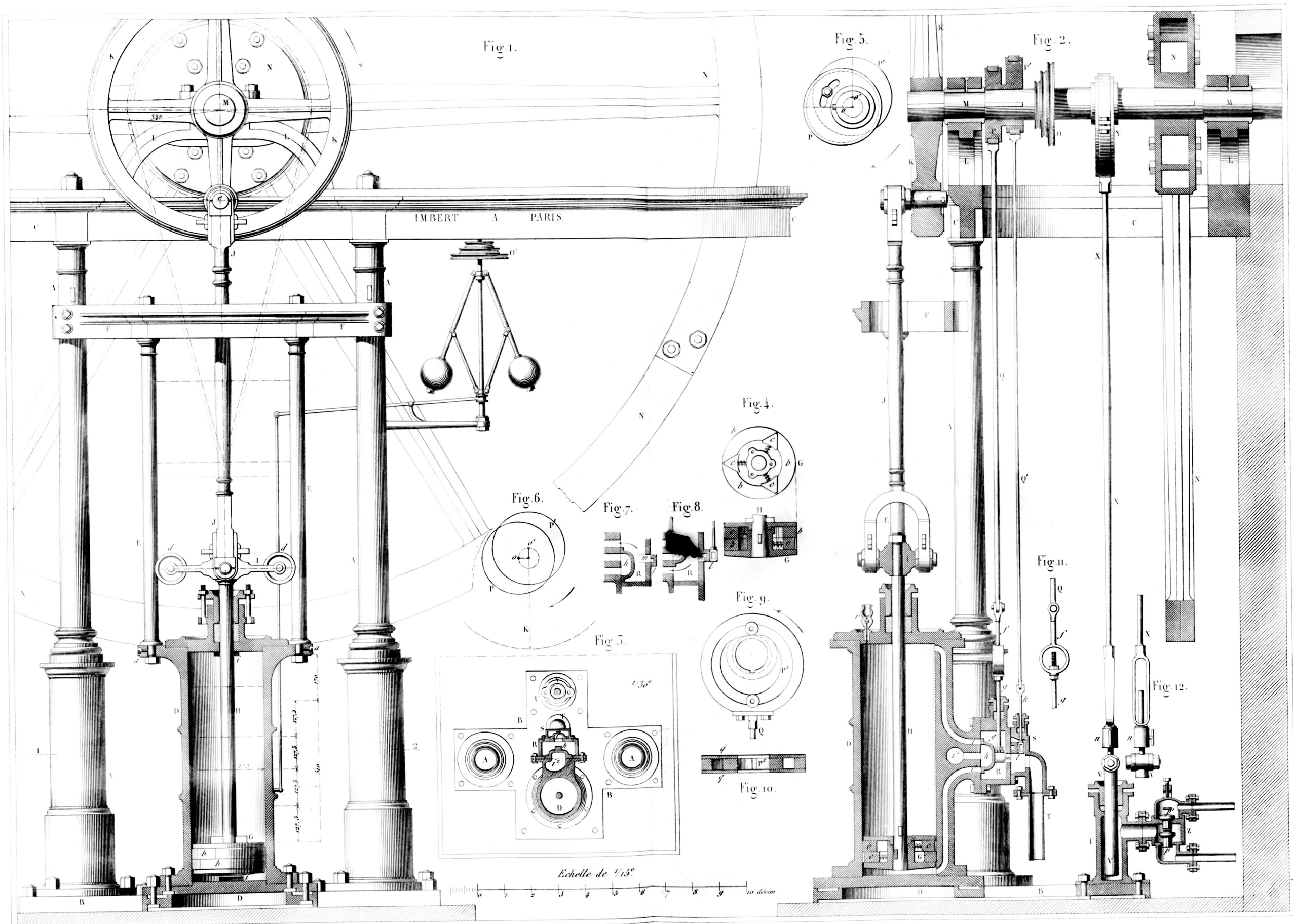

Fig. 1.

Fig. 5.

Fig. 2.

IMBERT A PARIS

Fig. 4.

Fig. 6.

Fig. 7.

Fig. 8.

Fig. 9.

Fig. 5.

Fig. 11.

Fig. 12.

Echelle de 1/15

Fig. 10.

10 decim

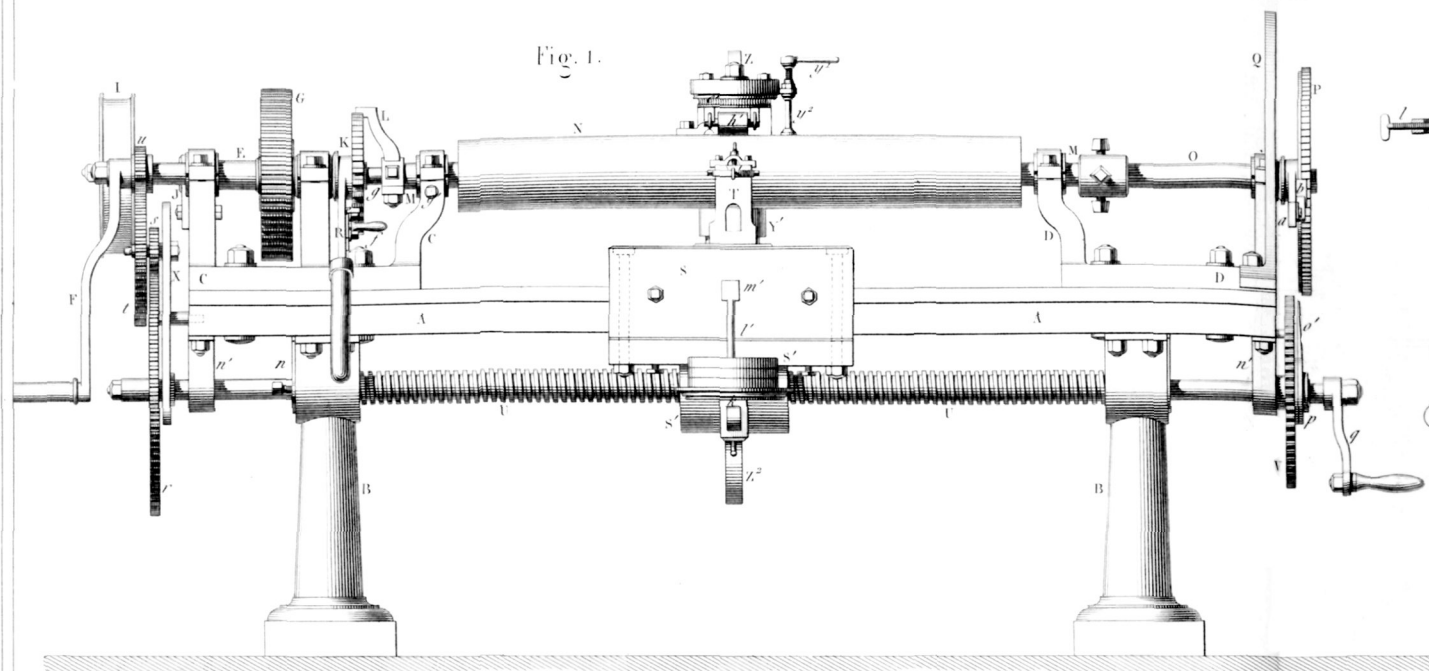

Fig. 1.

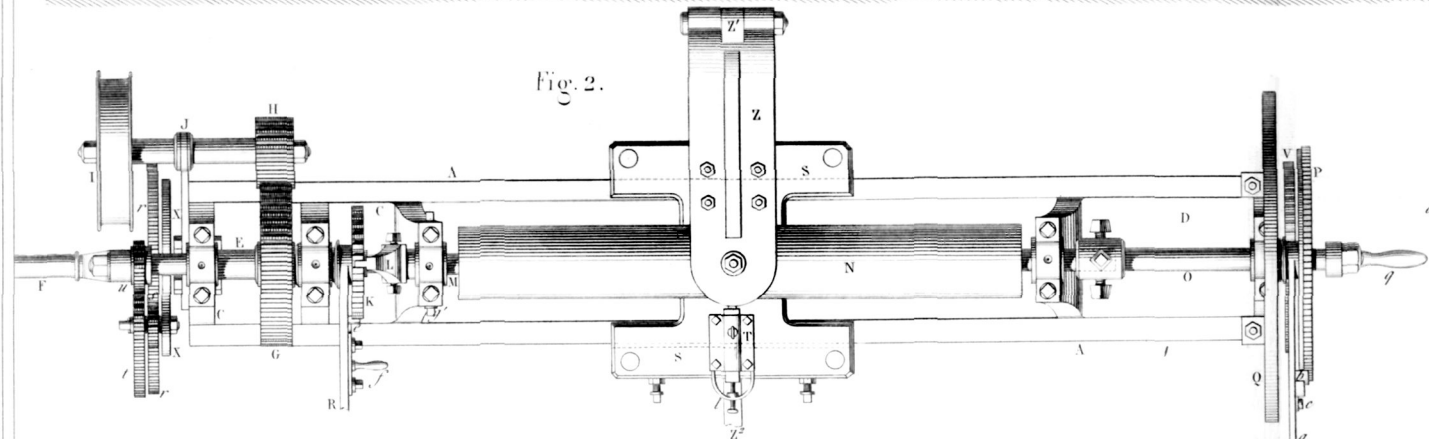

Fig. 2.

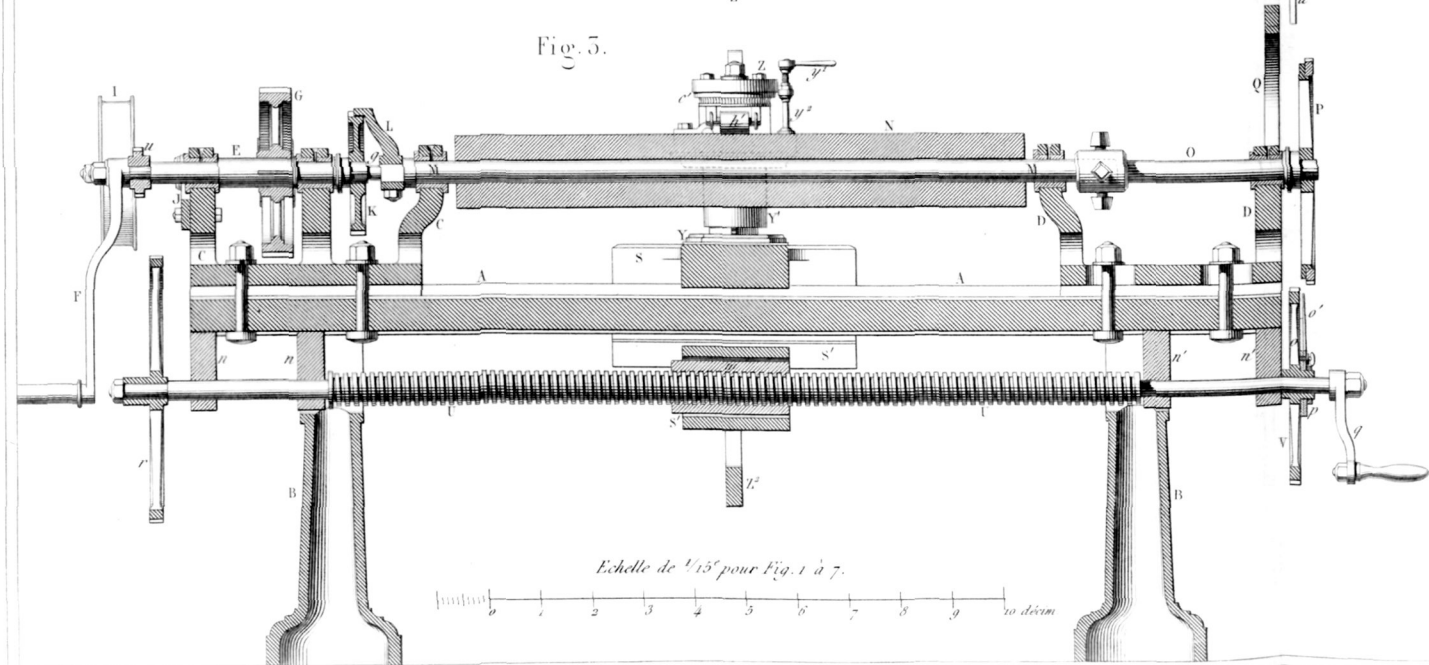

Fig. 5.

Echelle de 1/15^e pour Fig. 1 à 7.
 0 1 2 3 4 5 6 7 8 9 10 décim.

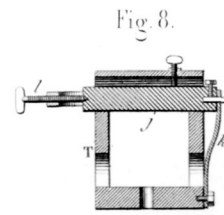

Fig. 8.

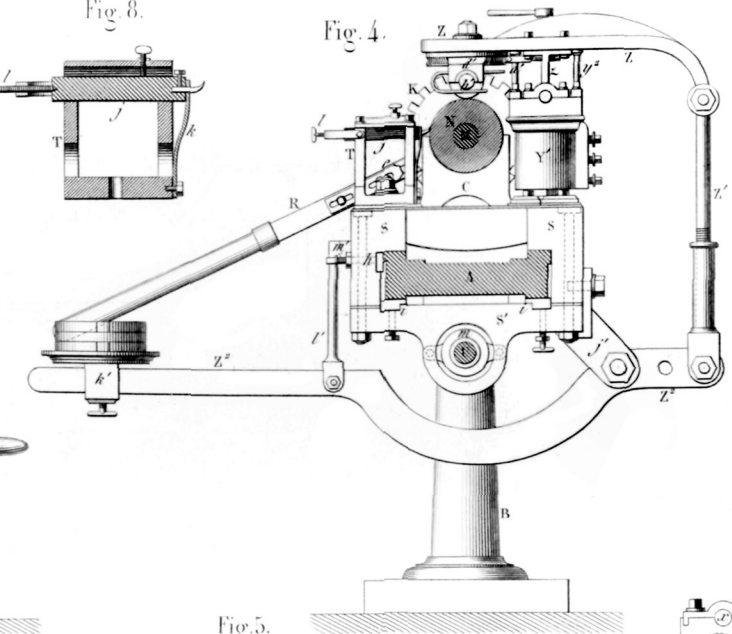

Fig. 4.

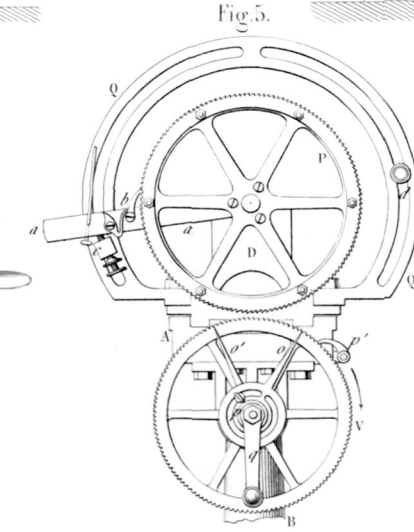

Fig. 5.

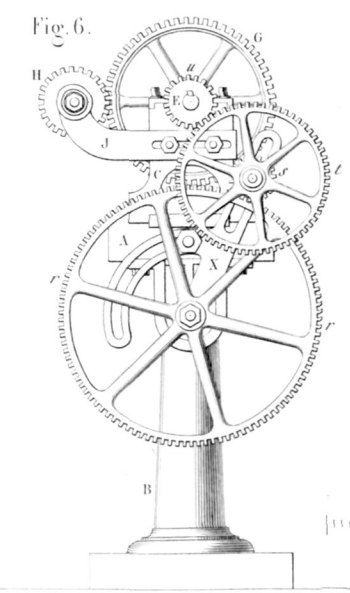

Fig. 6.

Echelle de 1/10^e pour Fig. 8 à 23.
 0 1 2 3 4 5 6 7 8 décim.

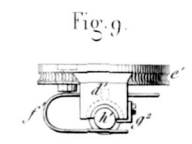

Fig. 9.

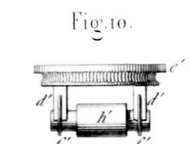

Fig. 10.

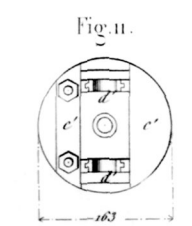

Fig. 11.

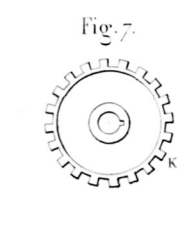

Fig. 7.

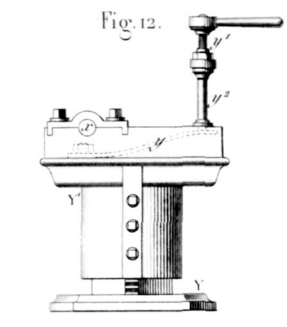

Fig. 12.

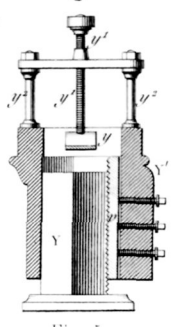

Fig. 14.

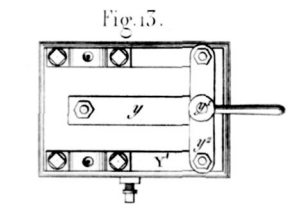

Fig. 15.

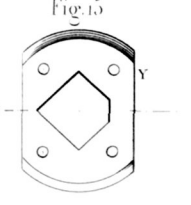

Fig. 15.

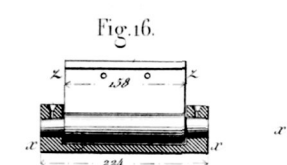

Fig. 16.

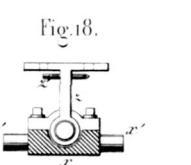

Fig. 18.

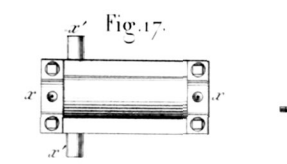

Fig. 17.



Fig. 19.

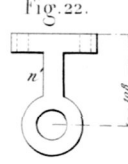

Fig. 21.

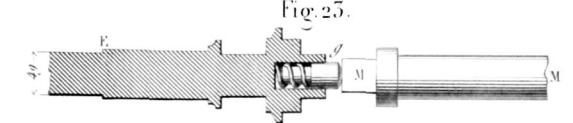
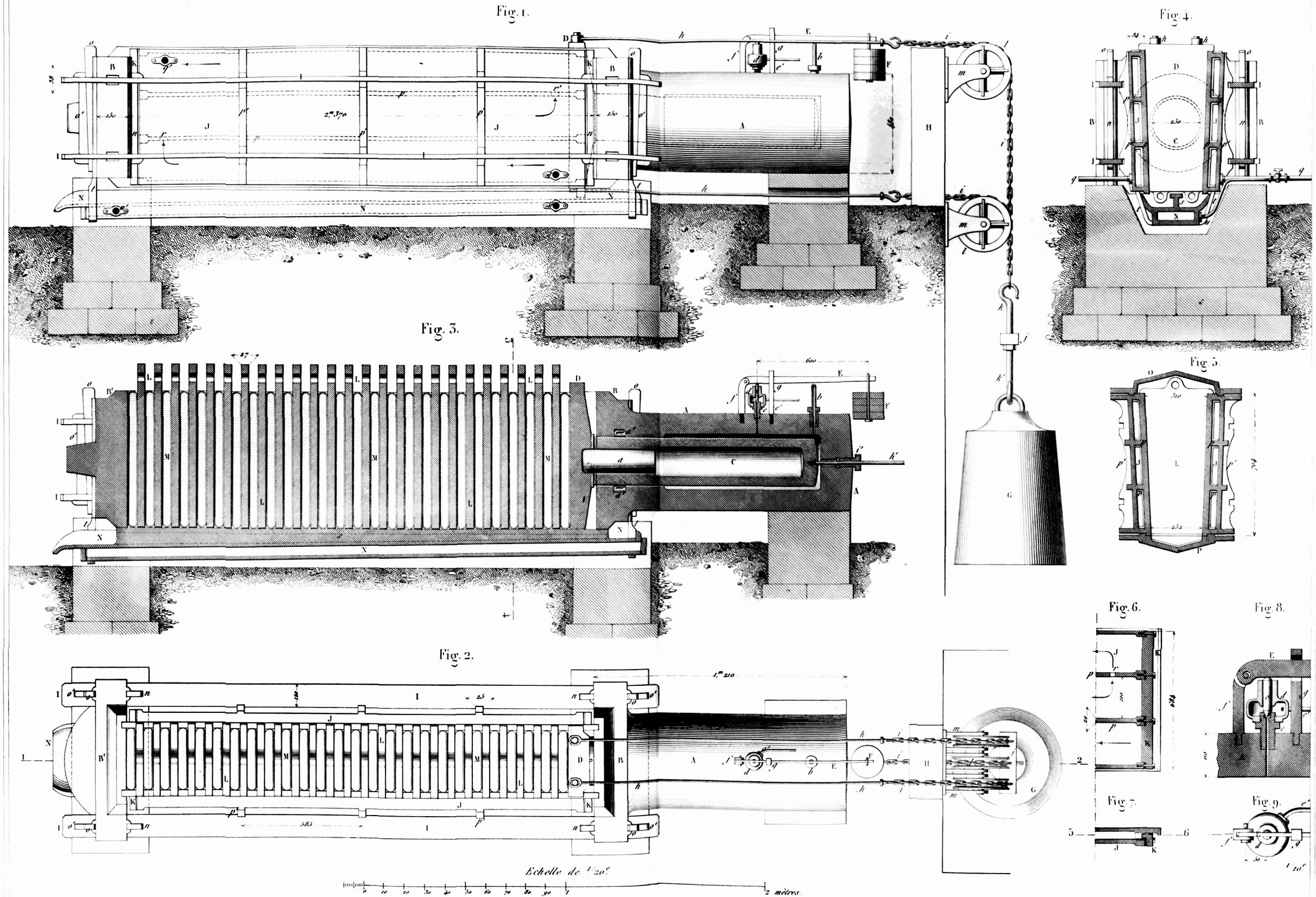
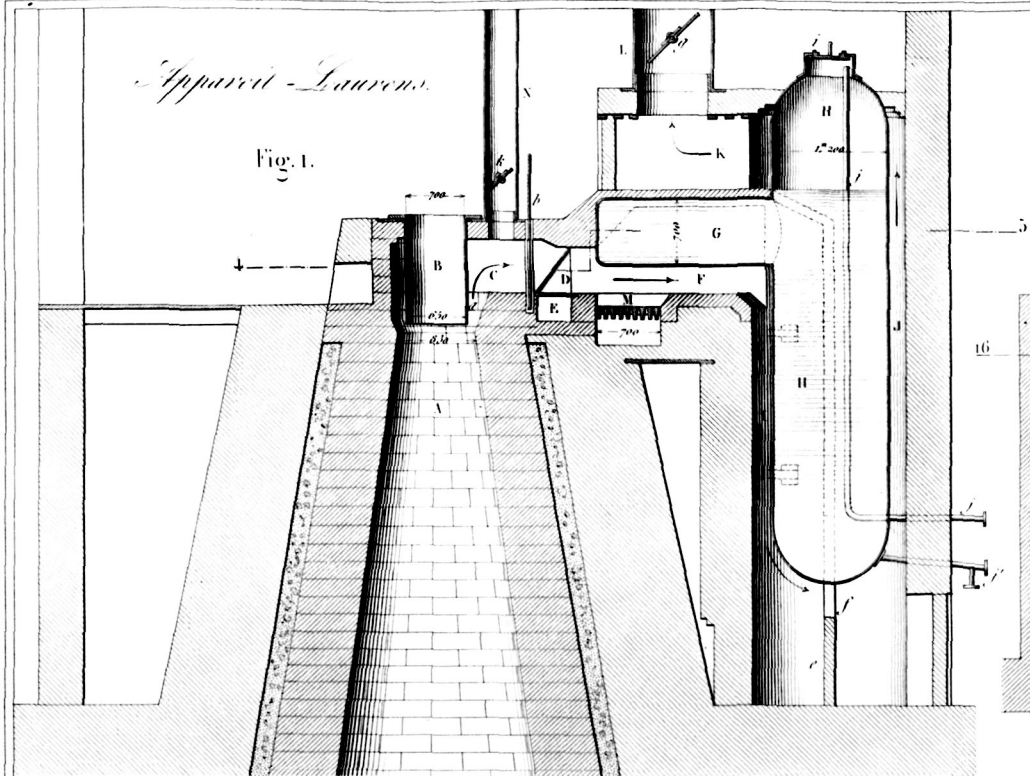

Fig. 25.



Appareil - Laurens.

Fig. 1.



Appareil de Söderström.
par M. Eug. Flachet.

Fig. 7.

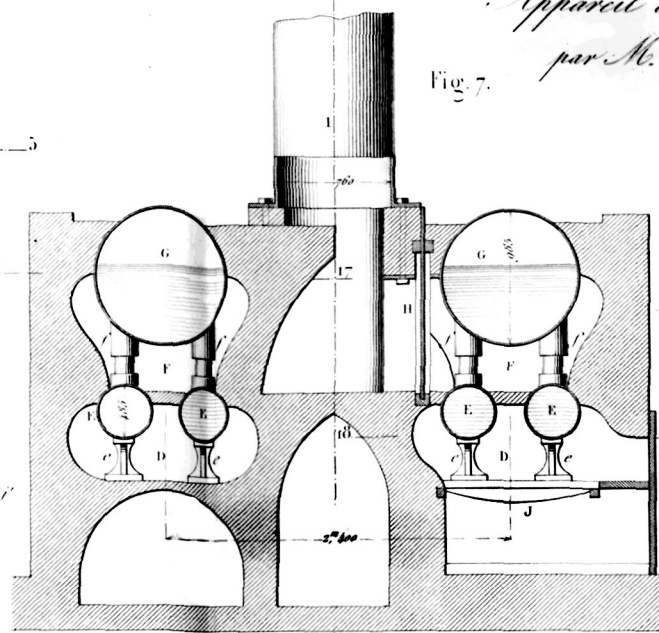

Fig. 8.

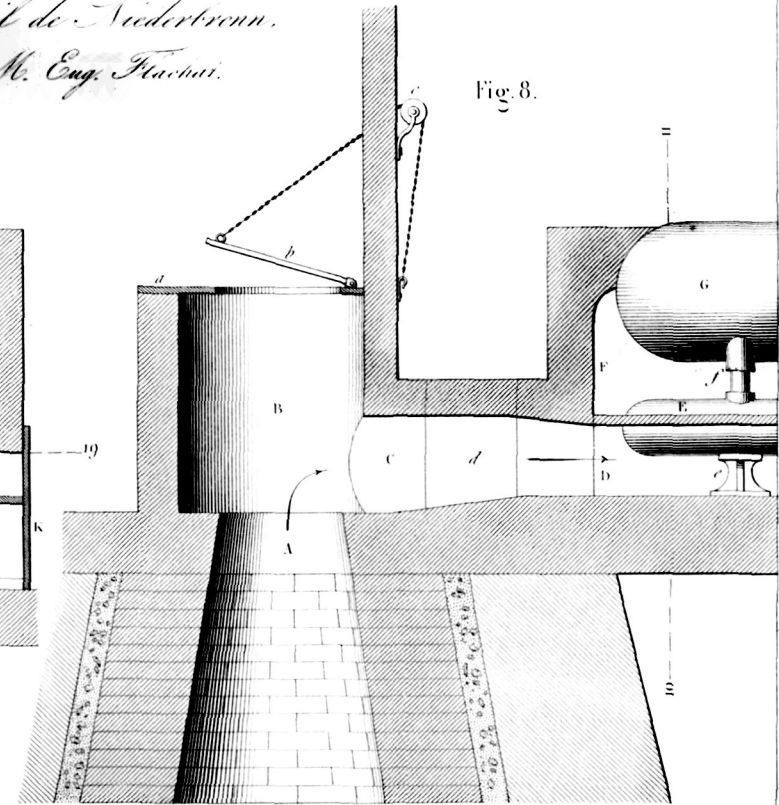
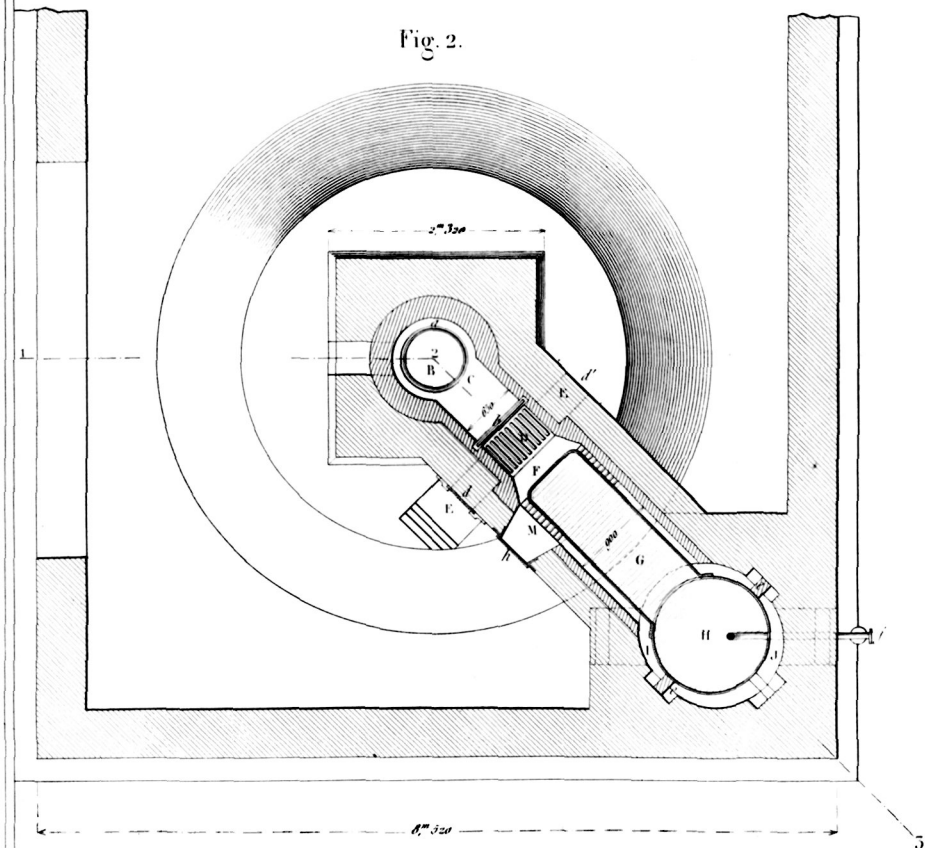

Fig. 2.



Appareil - Laurens.

Fig. 3.

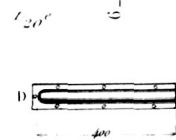
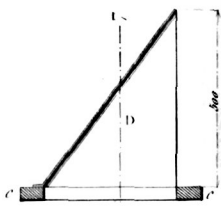

Fig. 4.

Fig. 5.

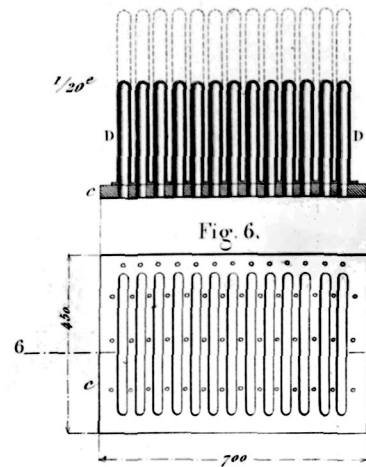

Fig. 6.

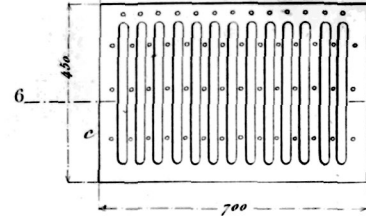
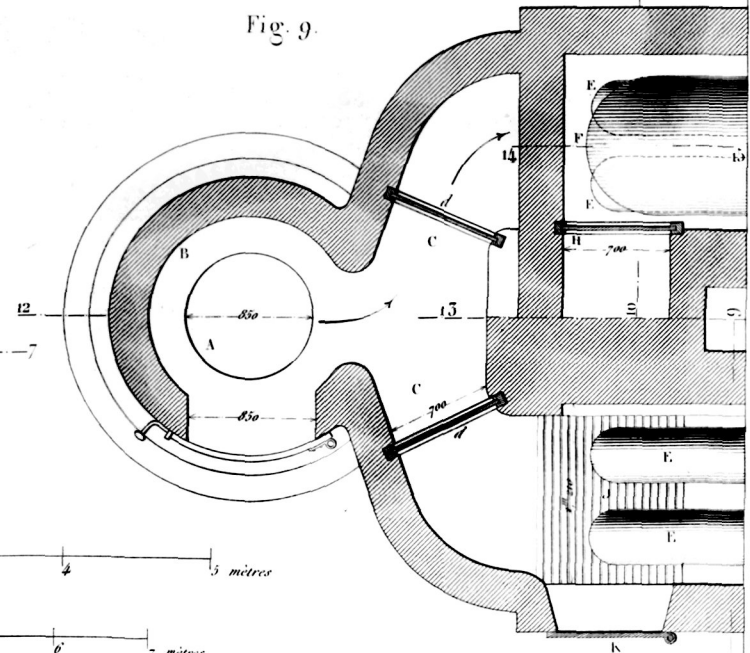
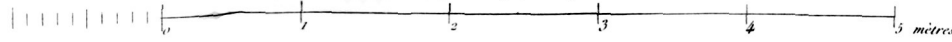

Fig. 9.



Echelle de 1/50 pour Fig. 7, 8 et 9.



Echelle de 1/80 pour Fig. 1 et 2.

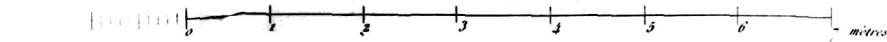

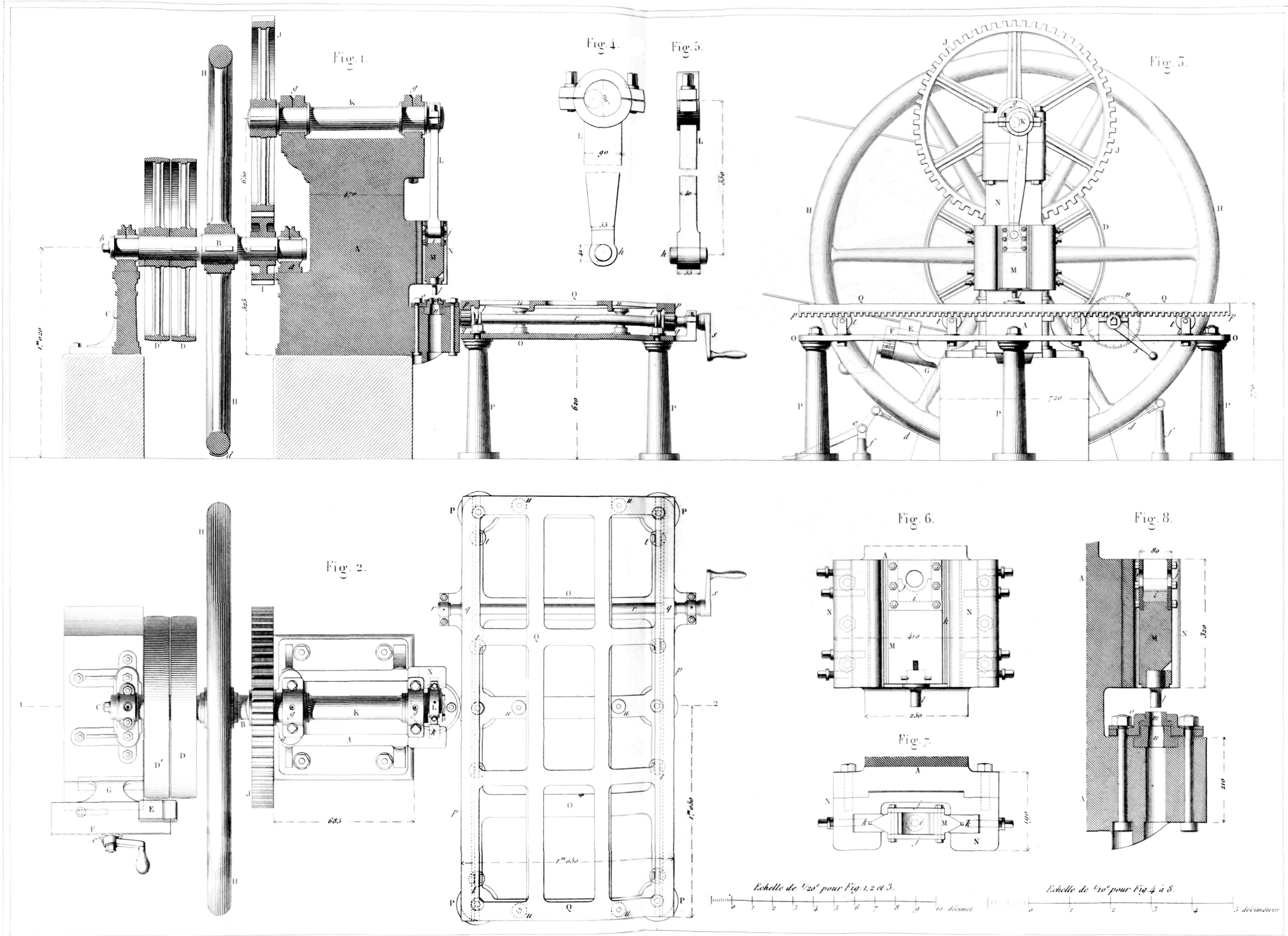

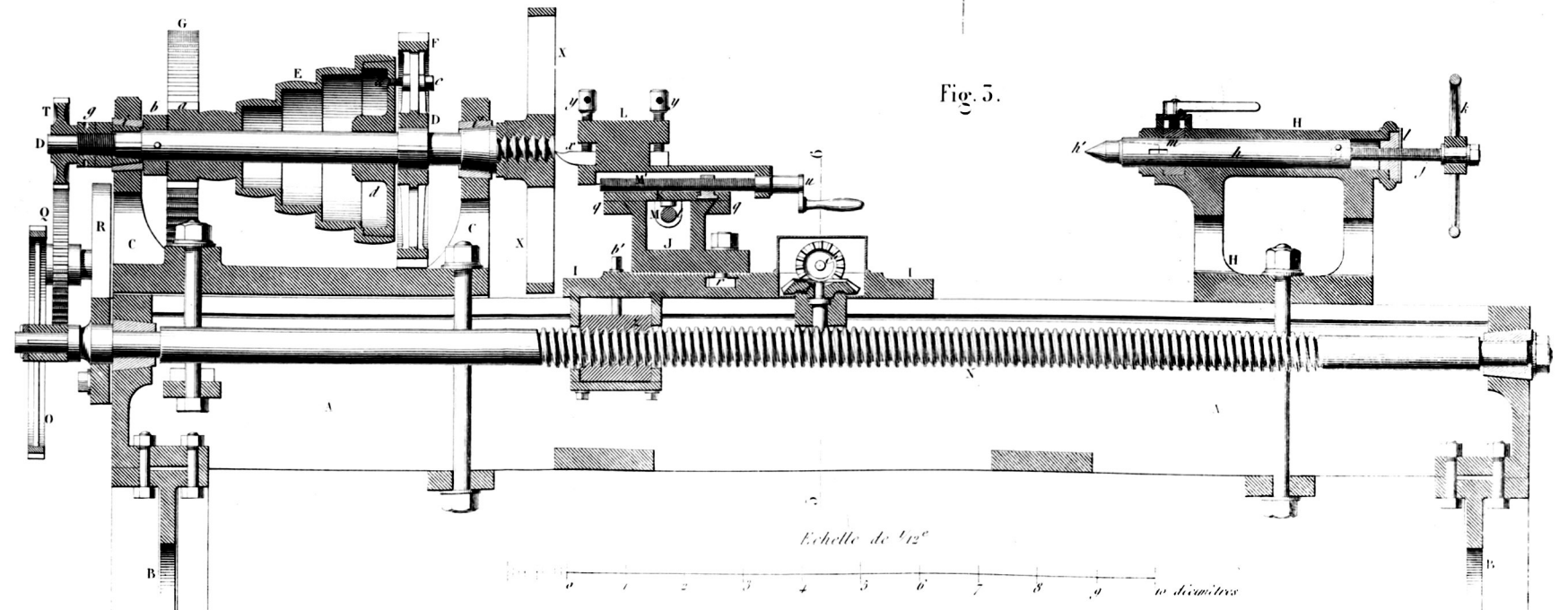
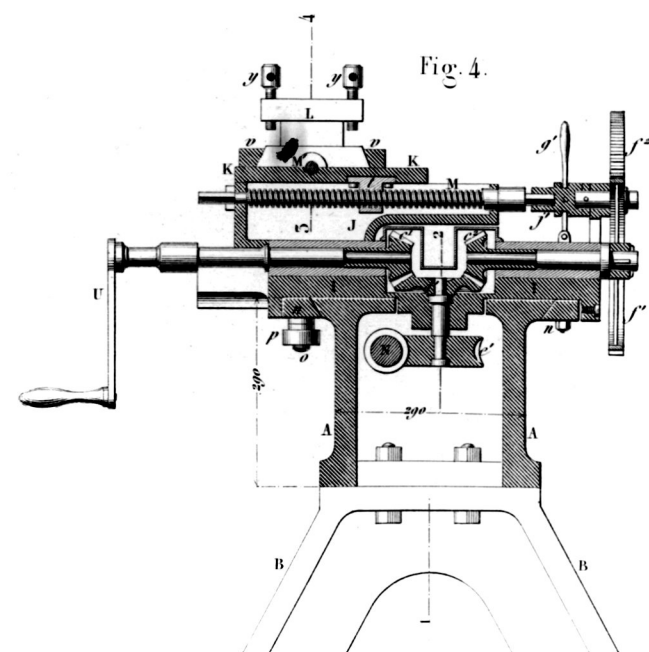
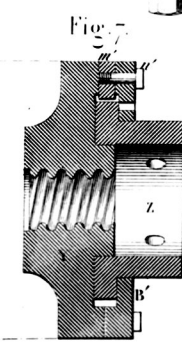
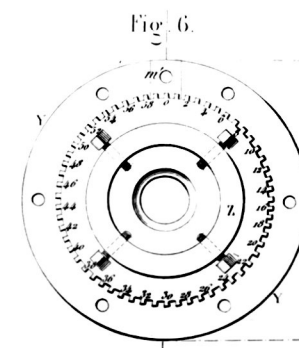
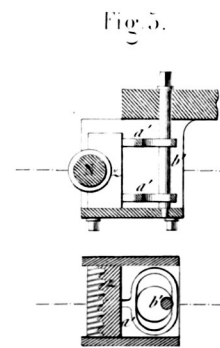
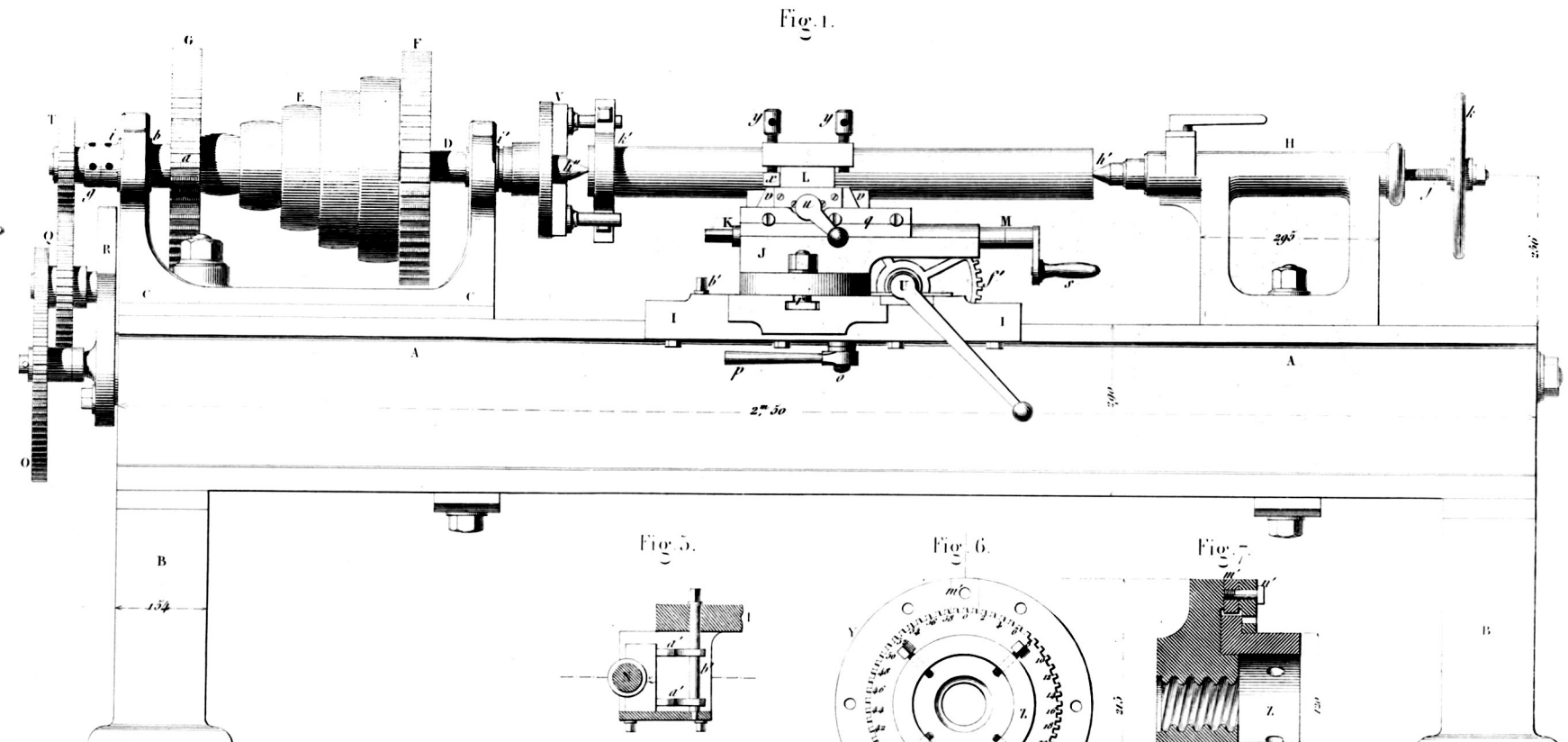
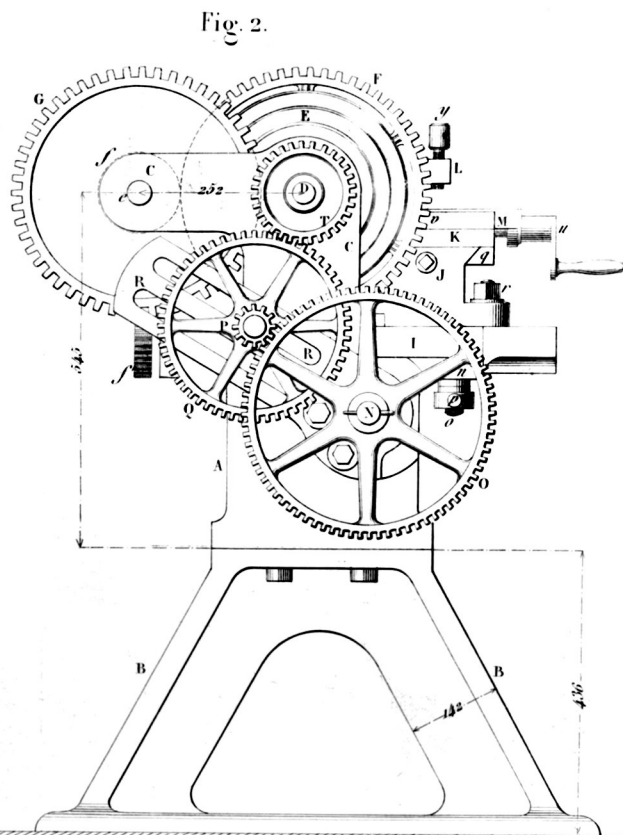

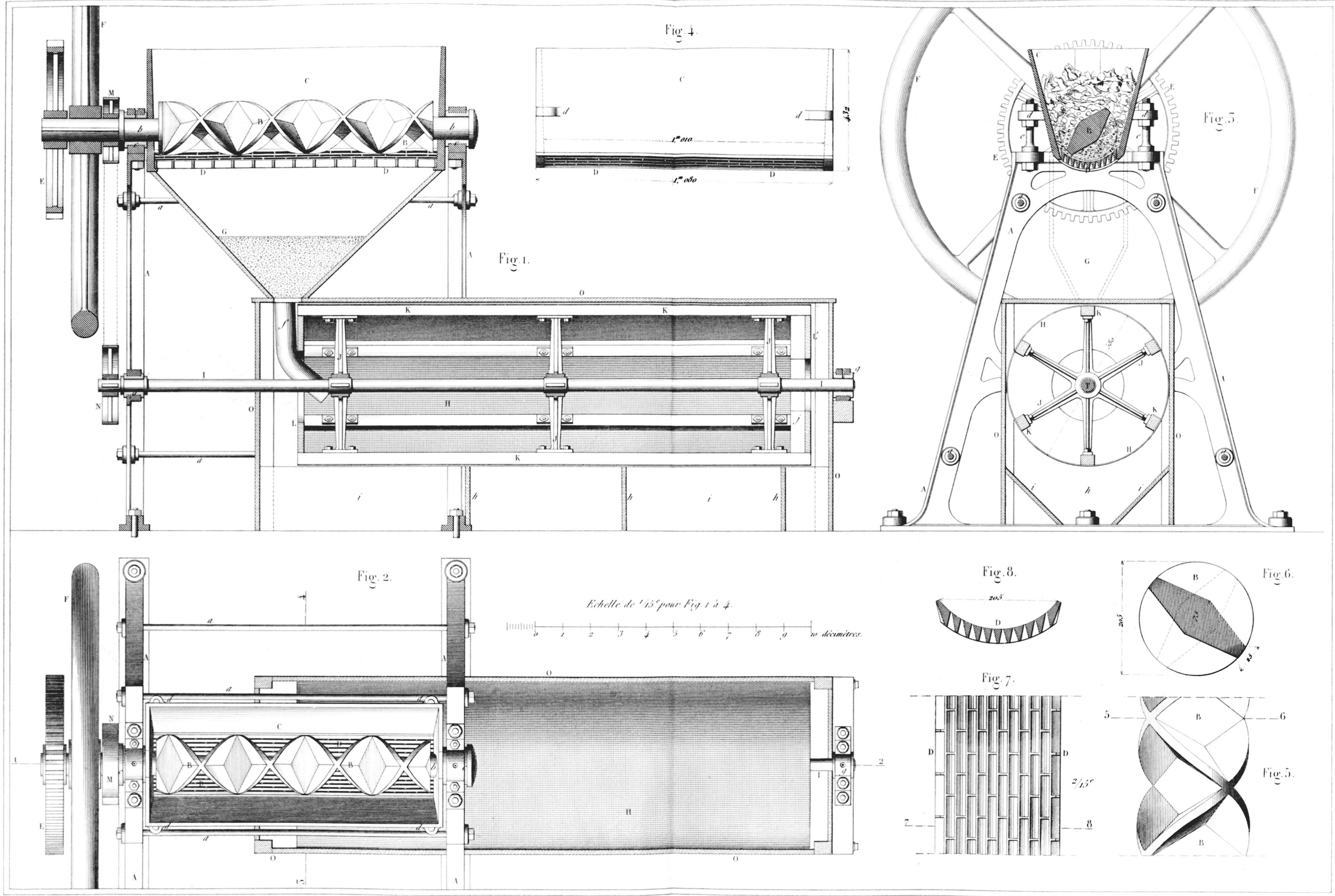

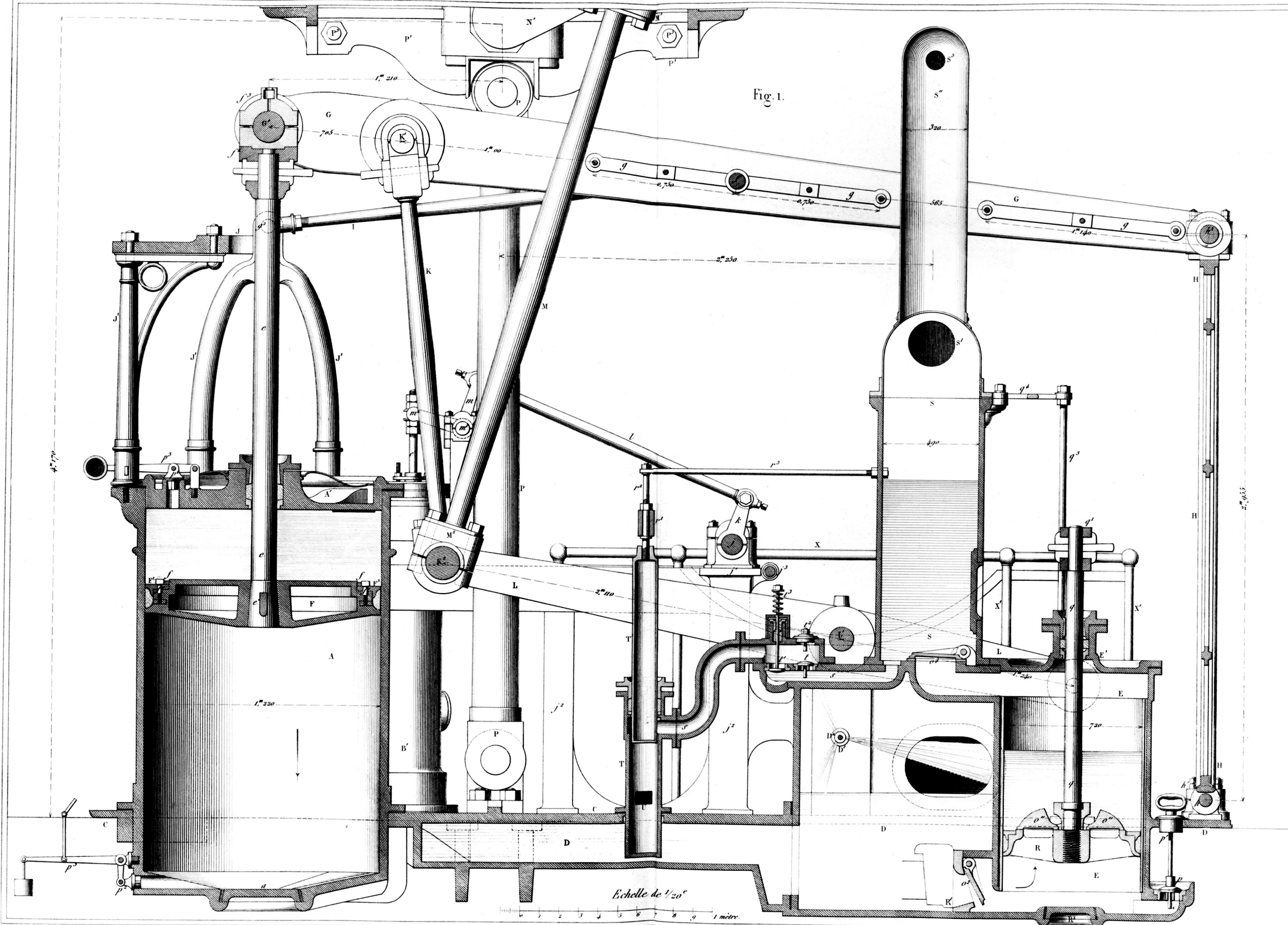

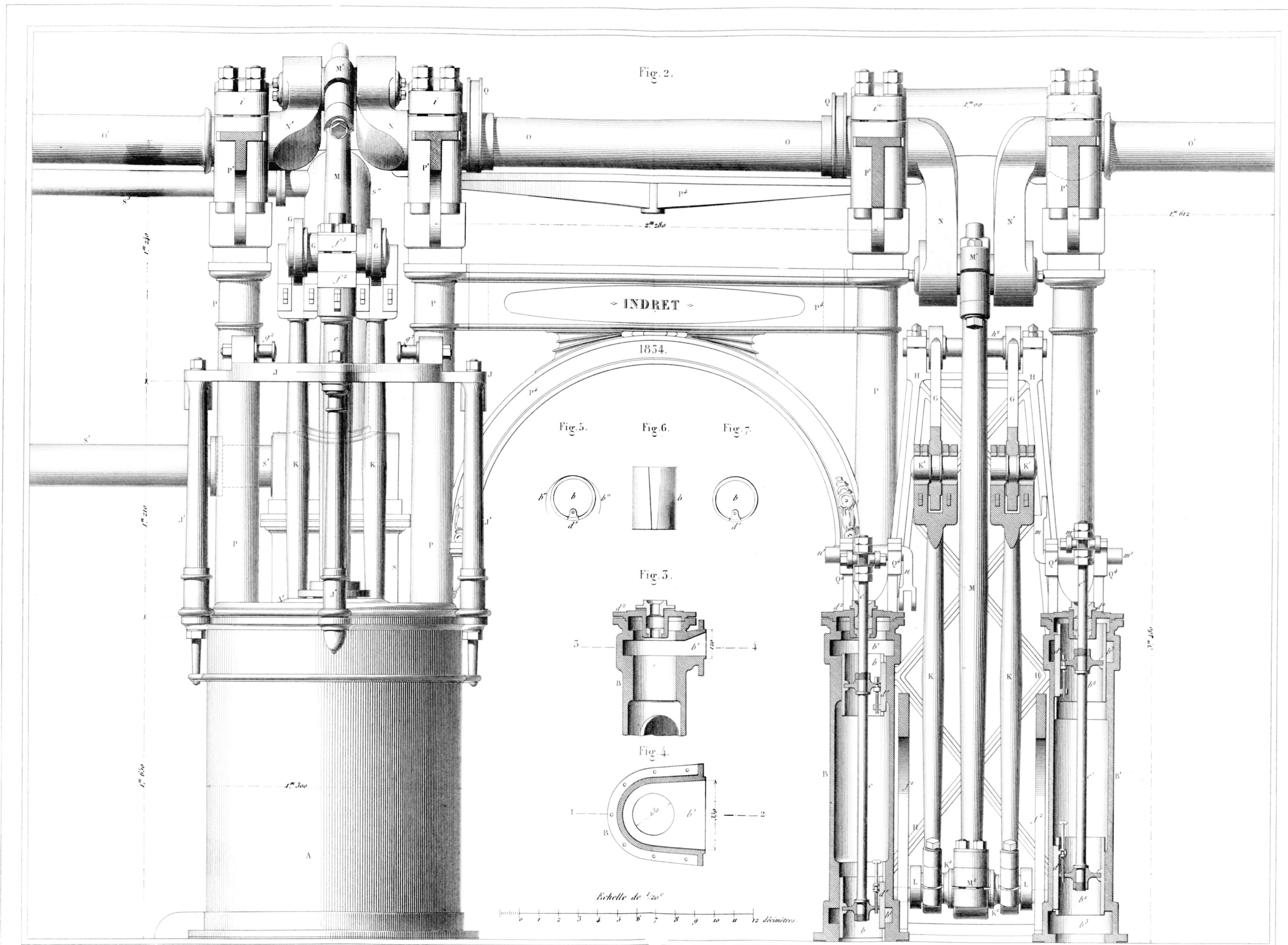

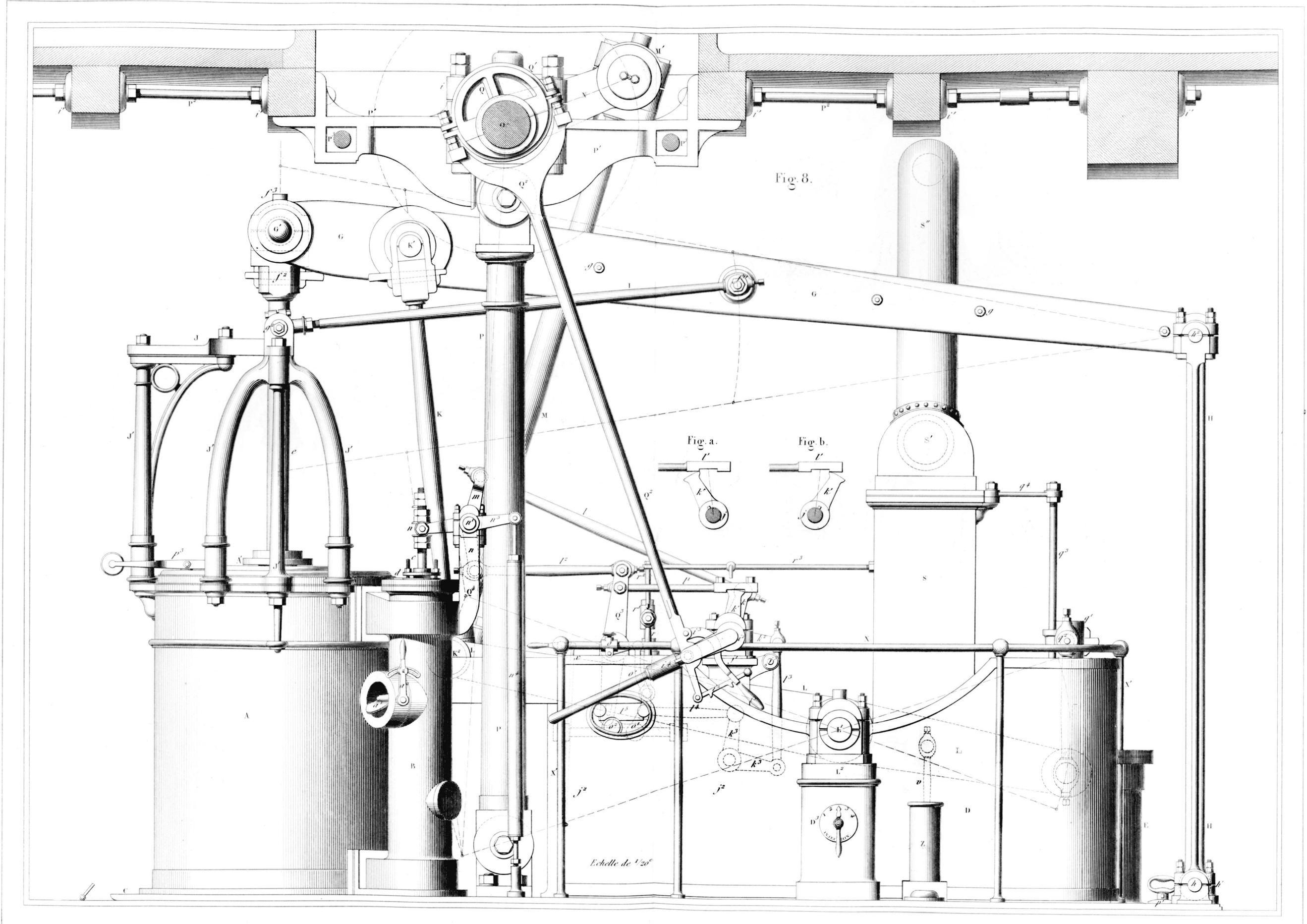

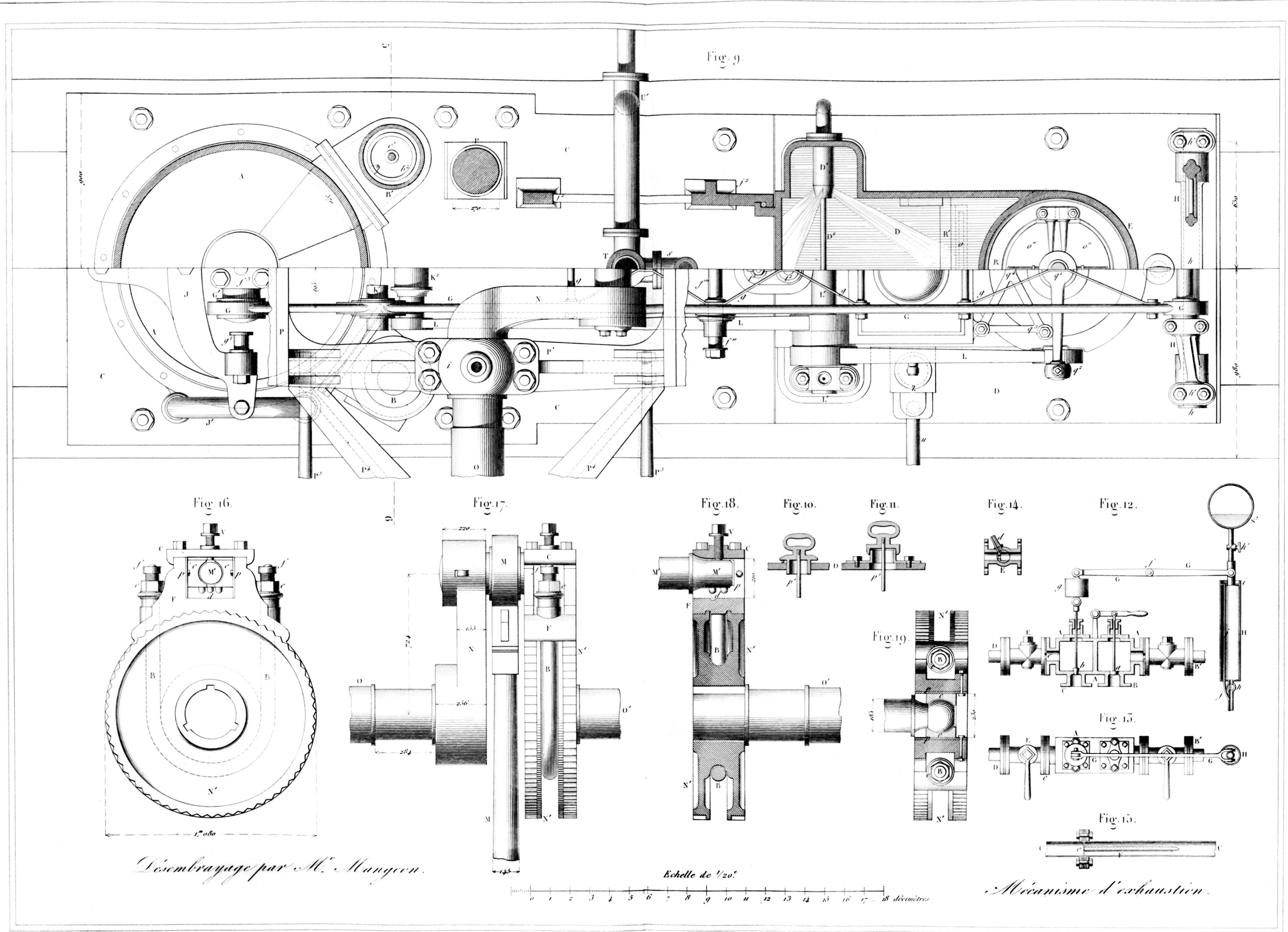

Désembrayage par M. Mangon.

Mécanisme d'exhaustion.

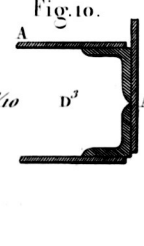
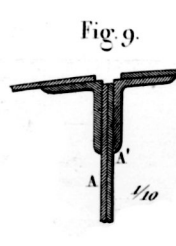
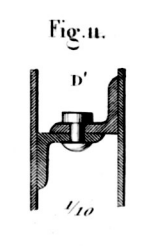
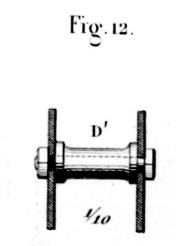
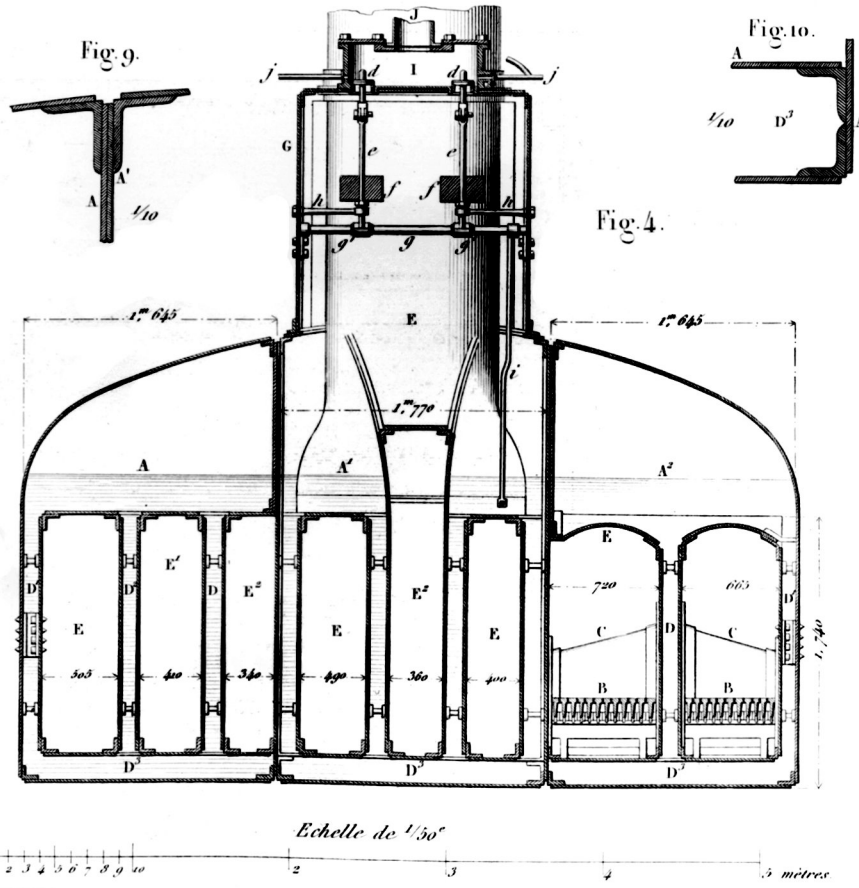
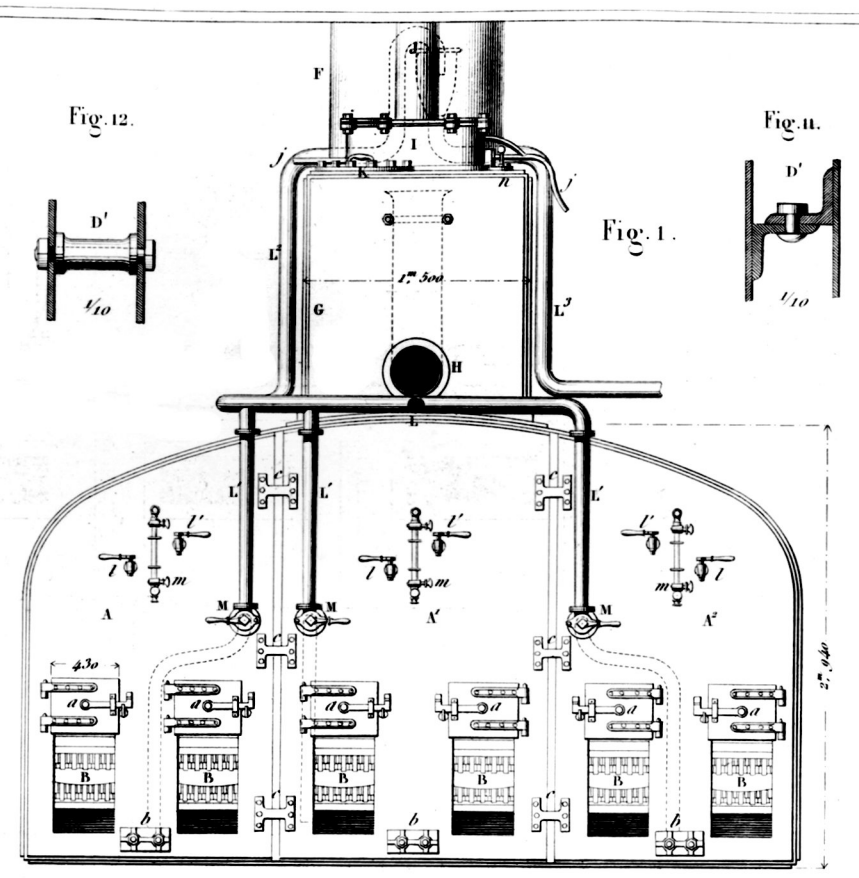
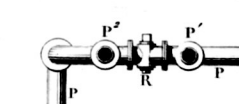
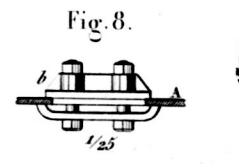
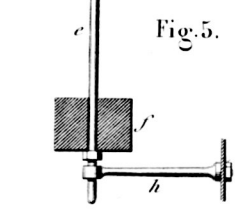
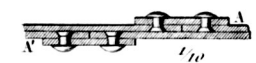
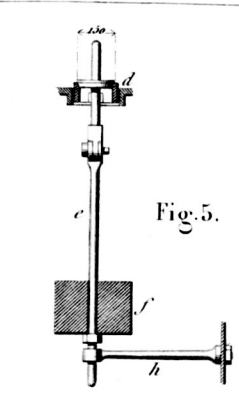
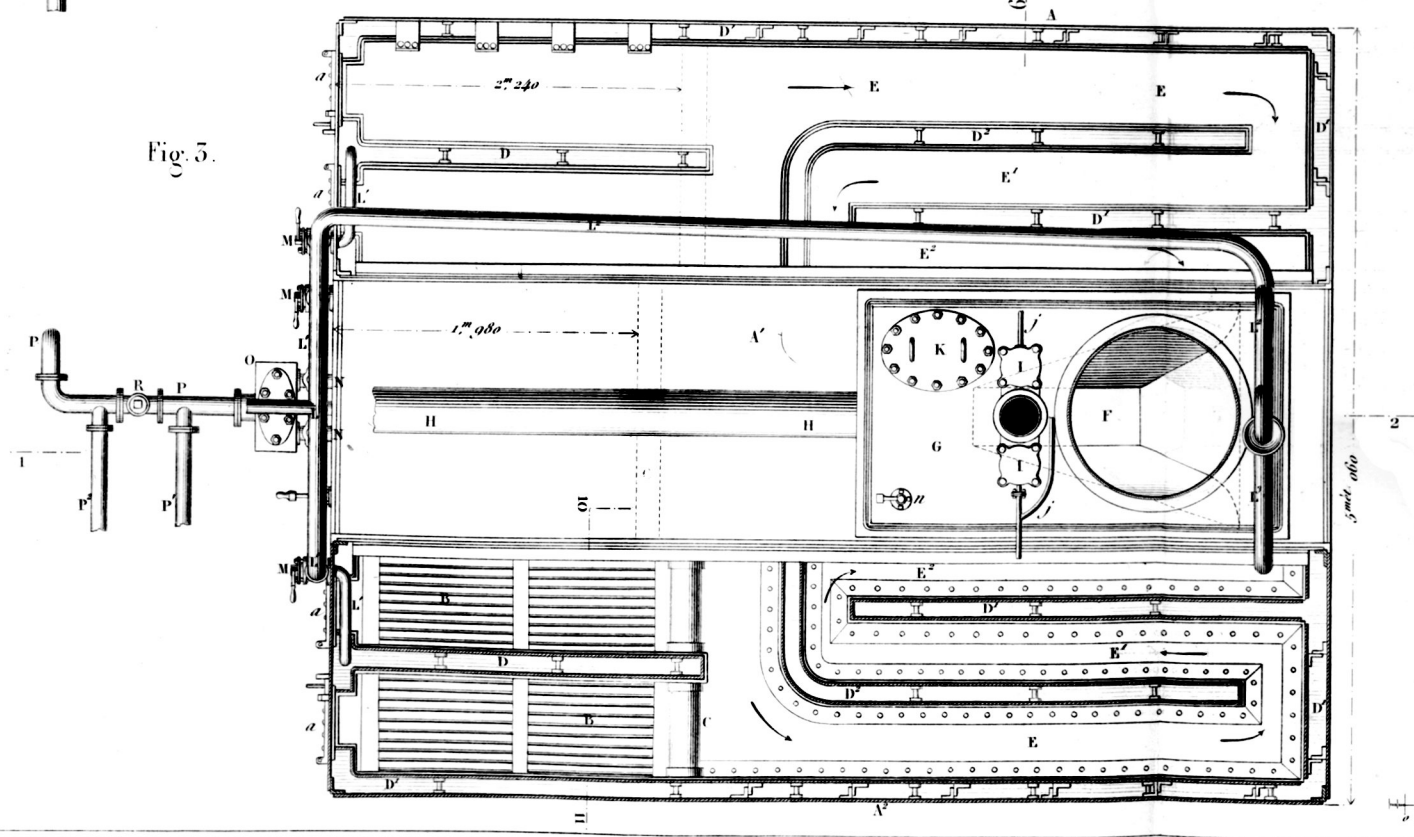
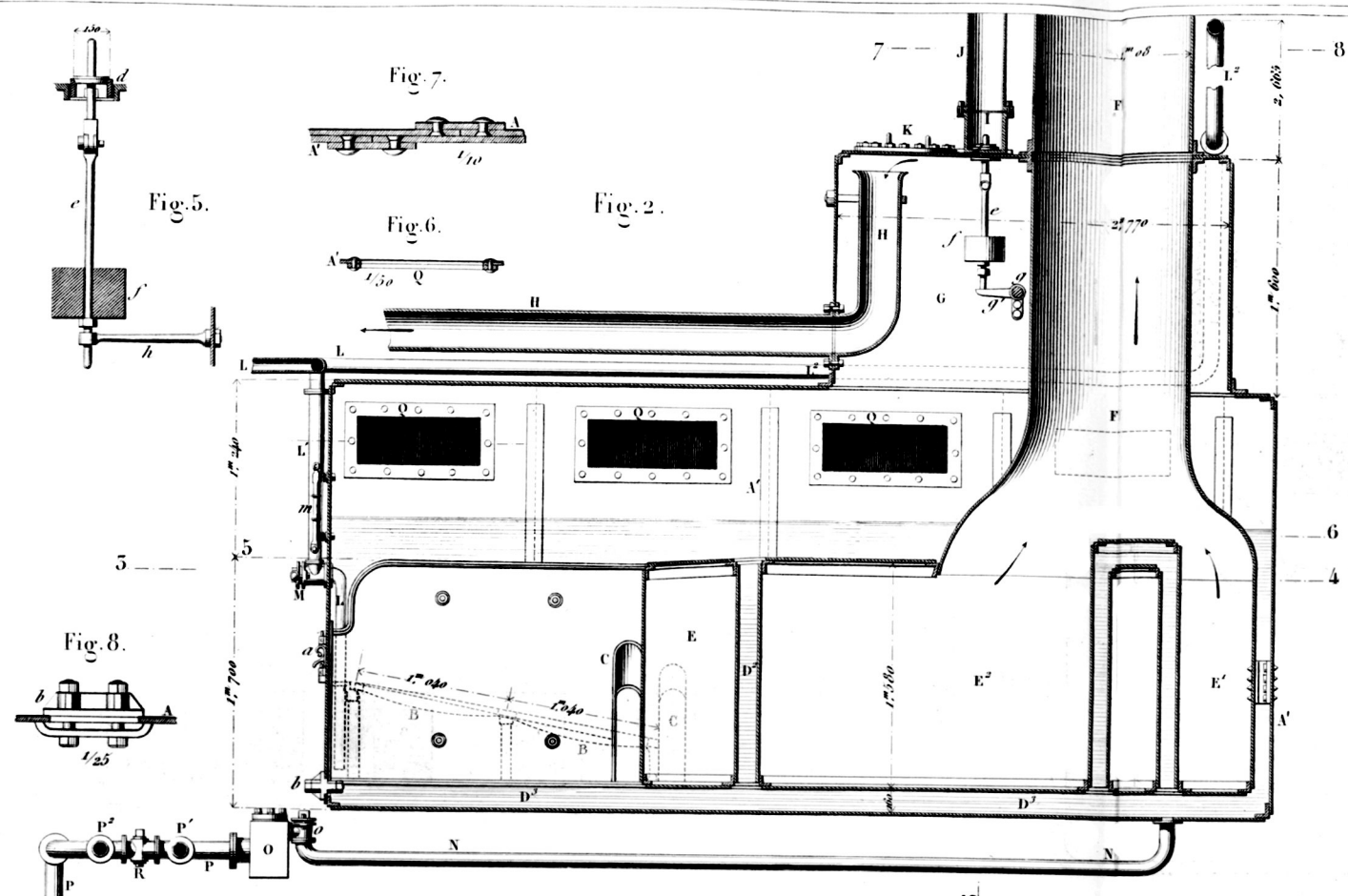

Echelle de 1/50^e



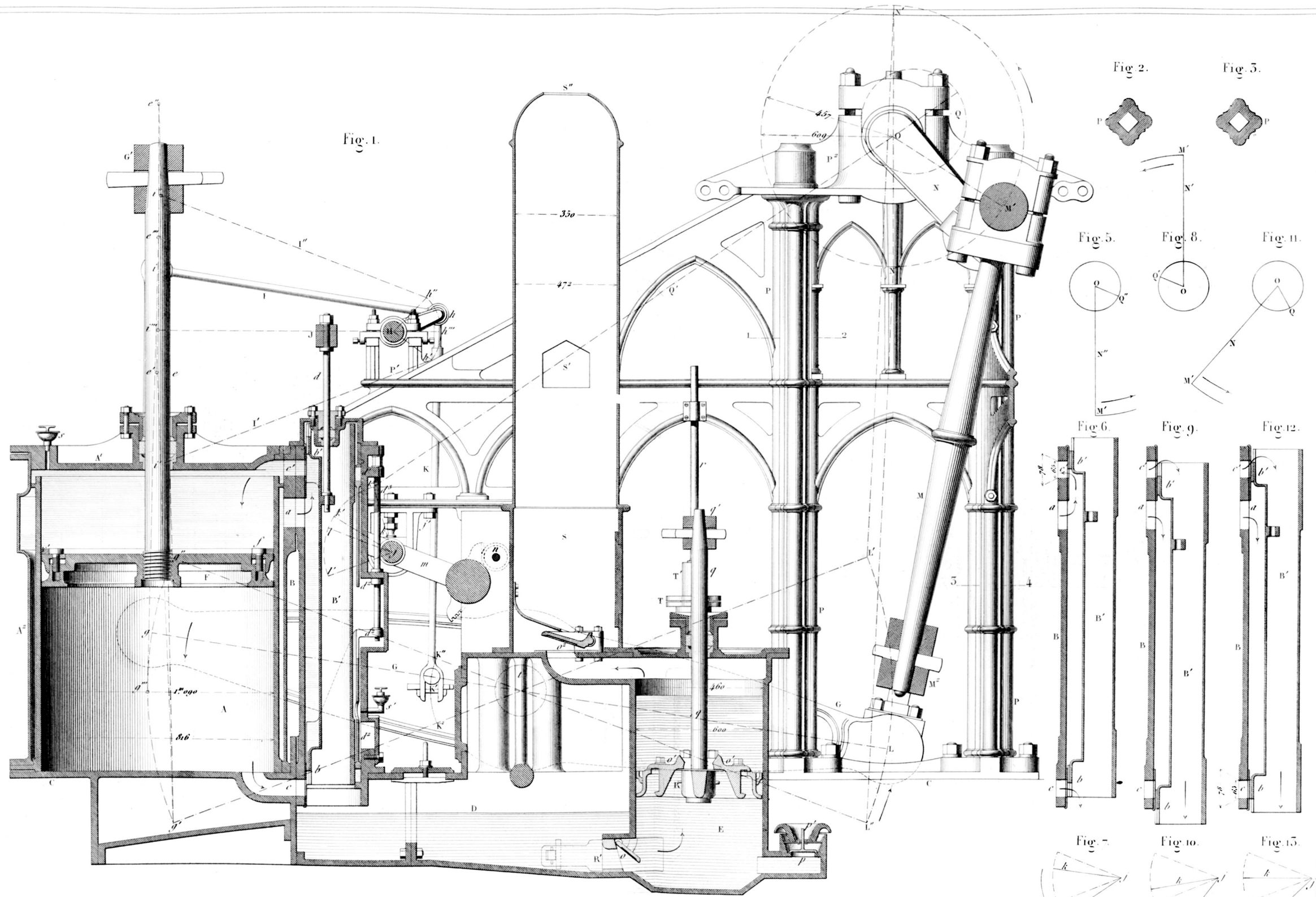

Echelle de 1/20^e pour 60 chevaux.

2 metres.

Echelle de 1/15^e pour 30 chevaux.

10 décimètres.

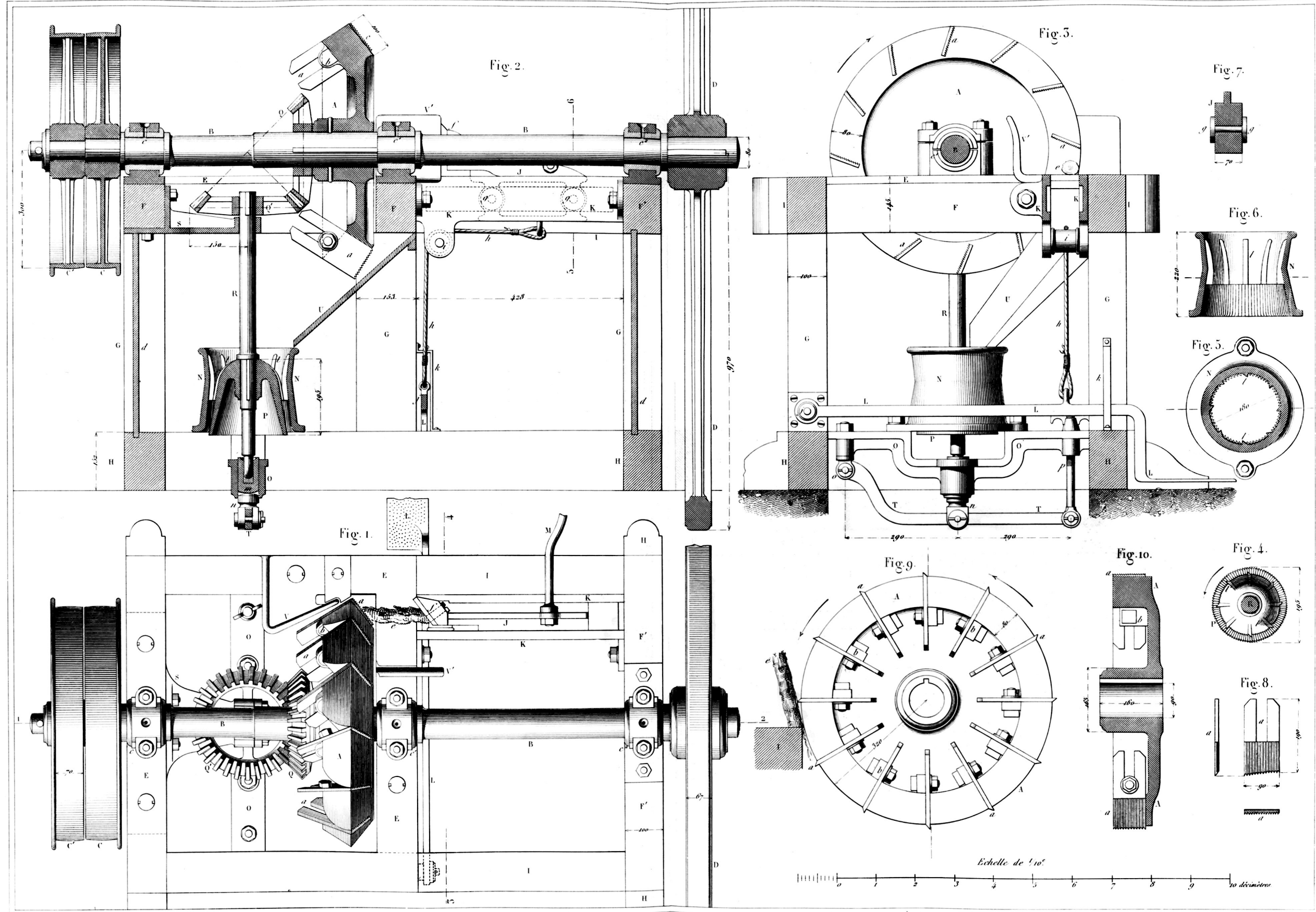

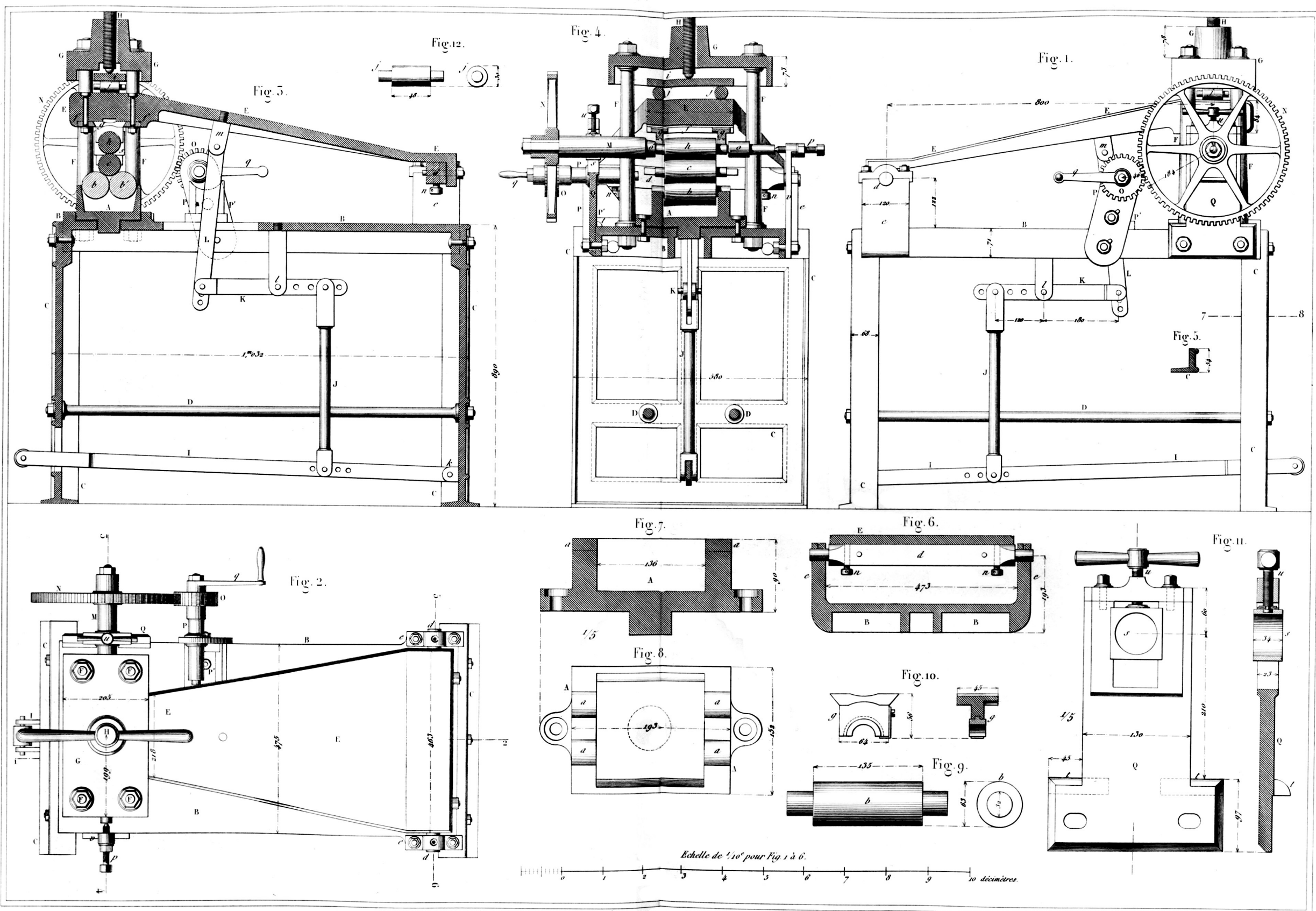

Echelle de 1/10^e pour Fig 1 à 6. 0 1 2 3 4 5 6 7 8 9 10 décimètres.

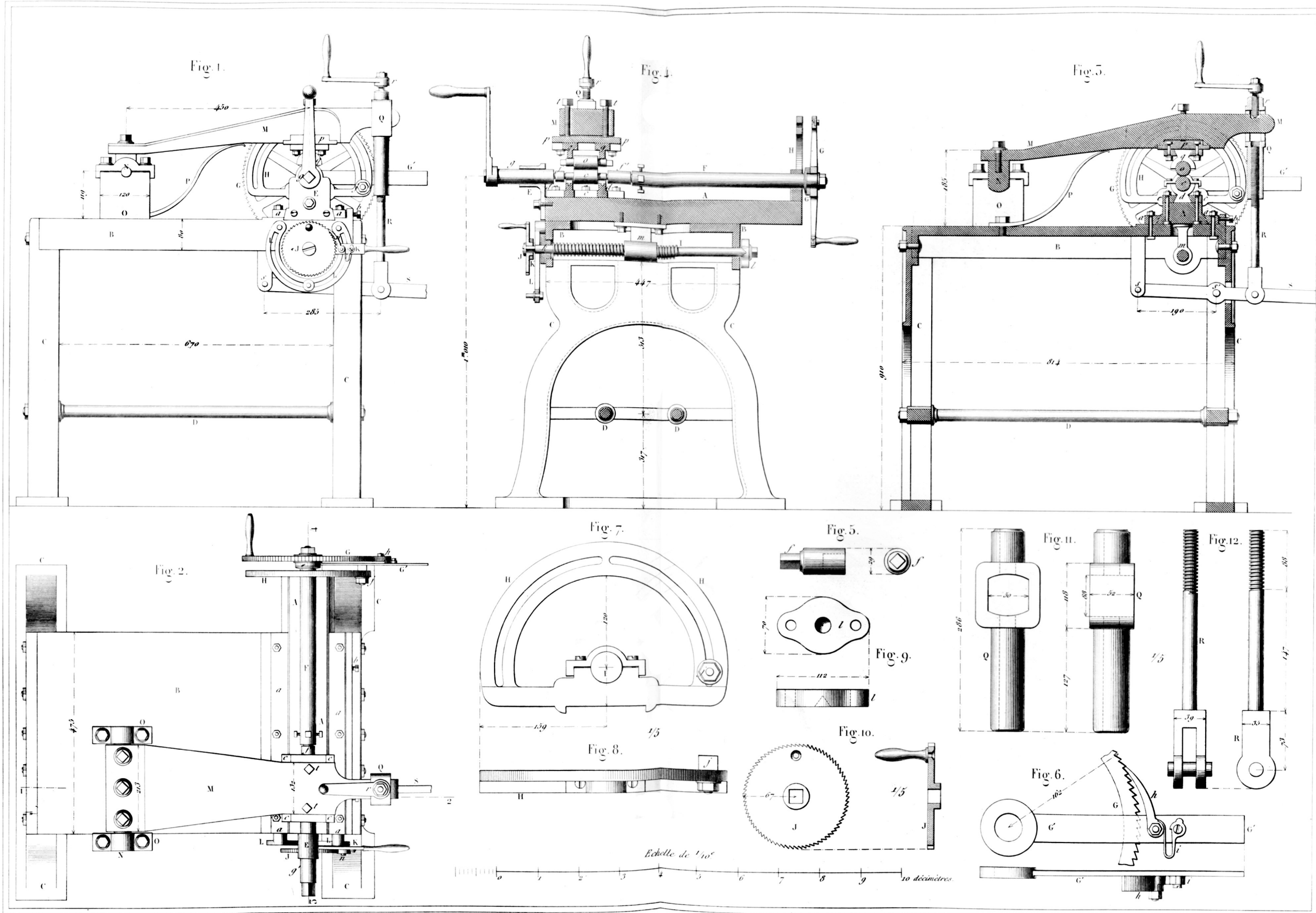

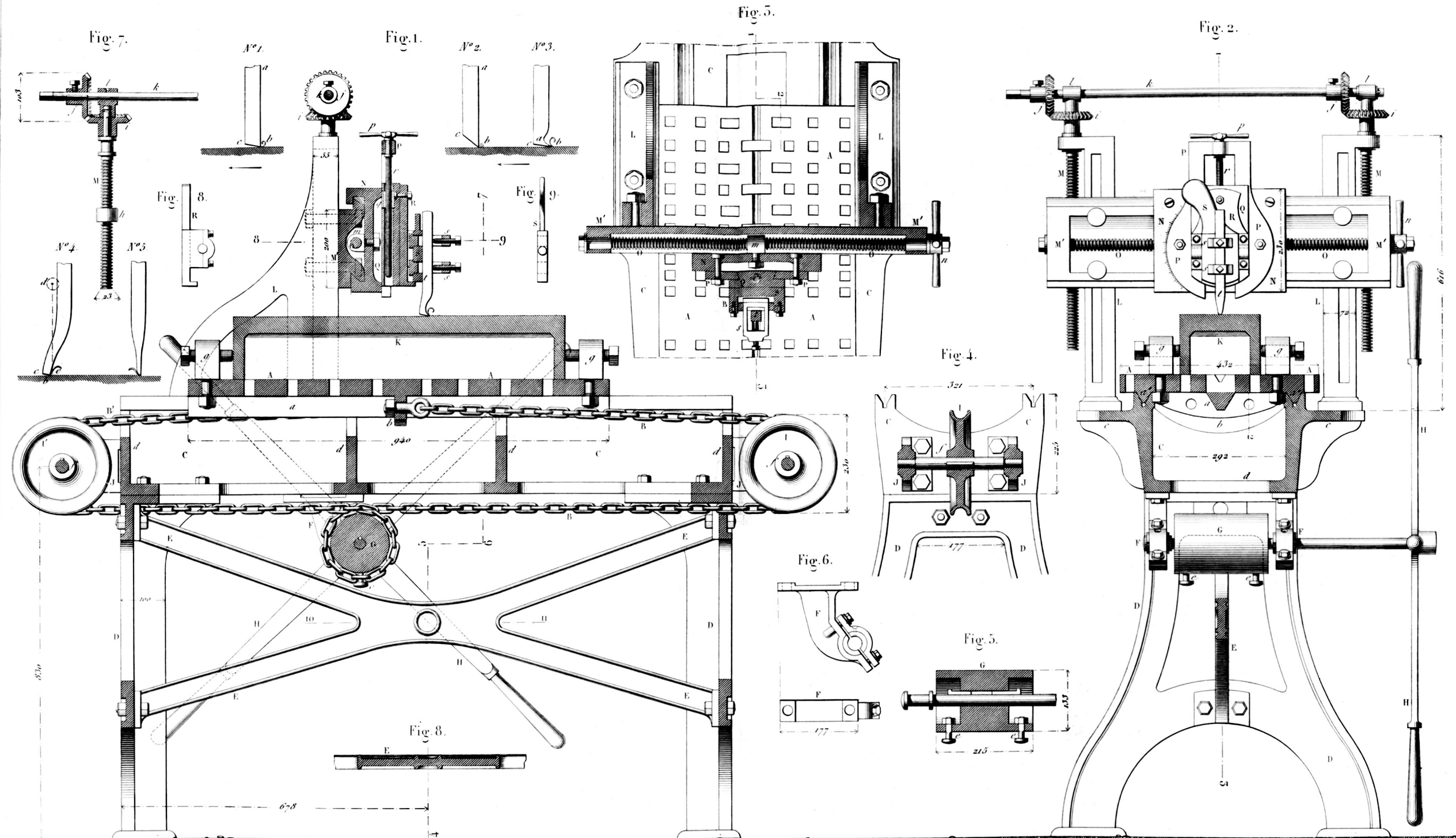

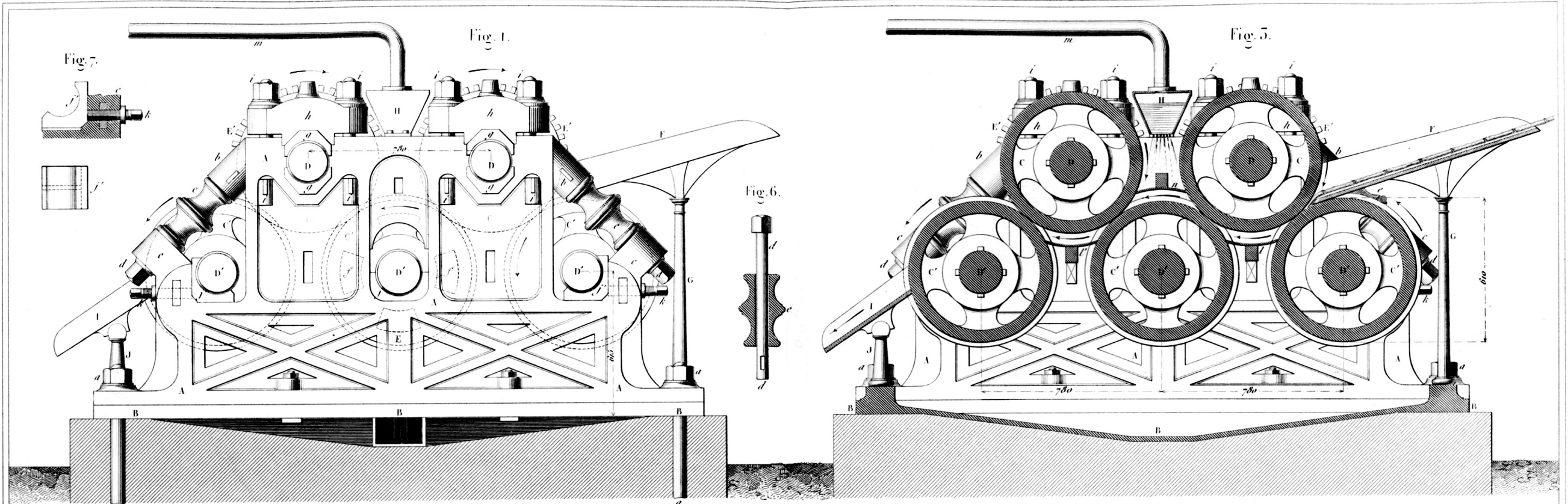

Fig. 7.

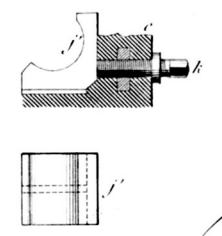

Fig. 6.

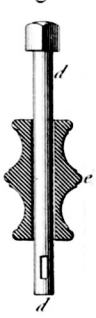
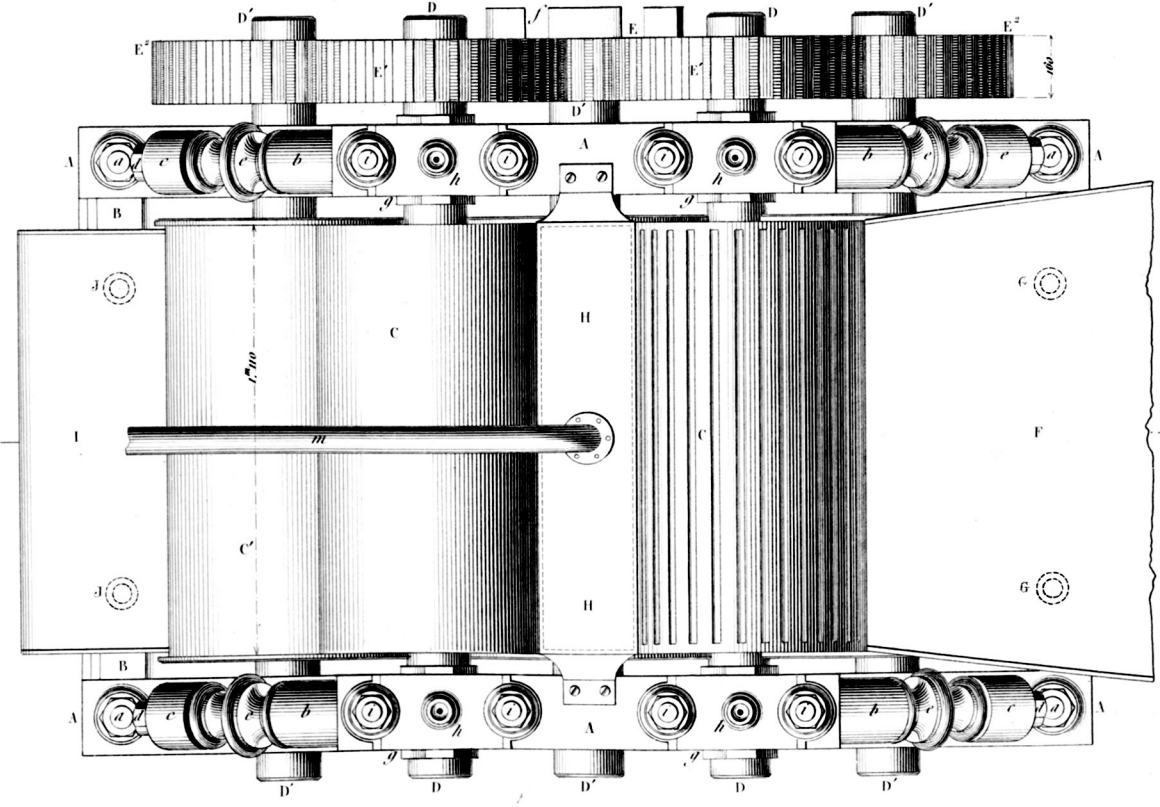

Fig. 2.



Echelle de 1/20^e

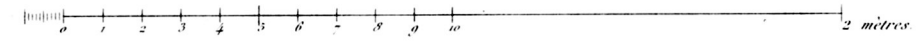

Fig. 4.

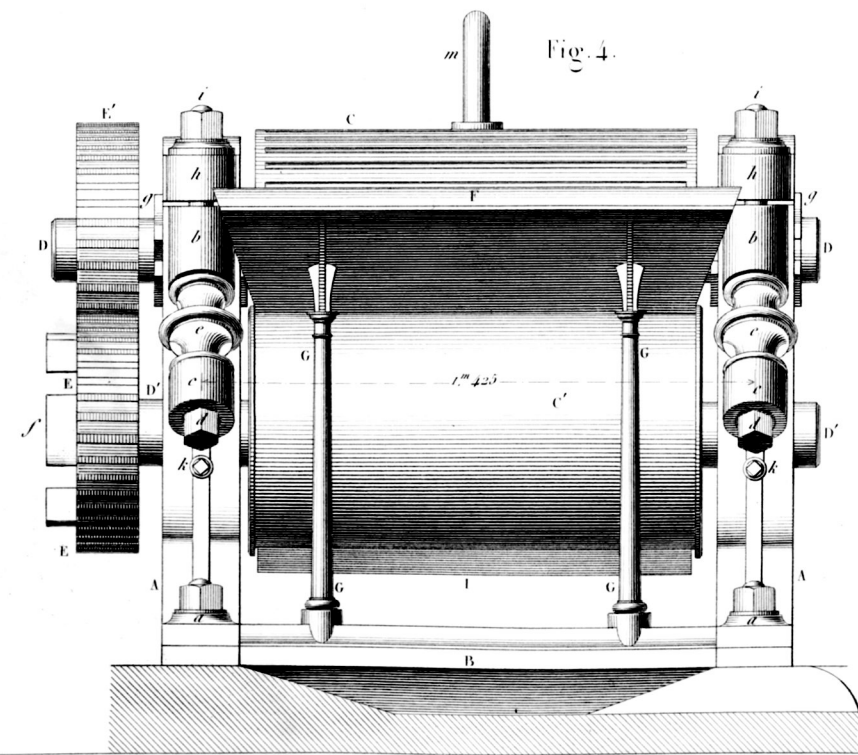

Fig. 5.

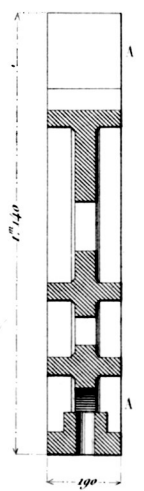
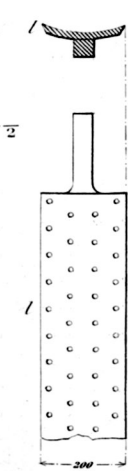
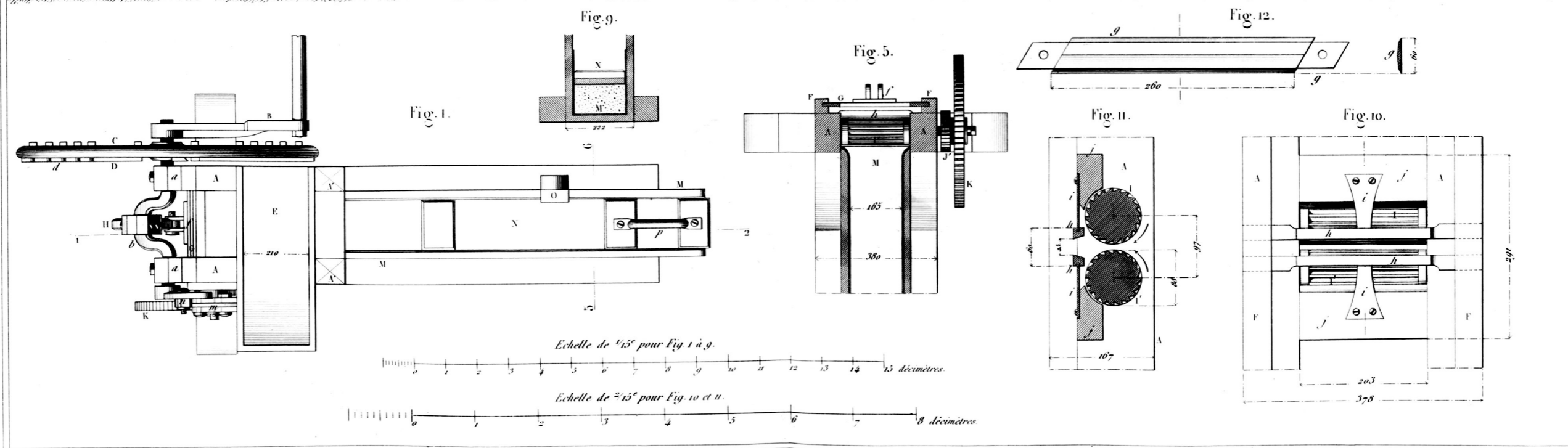
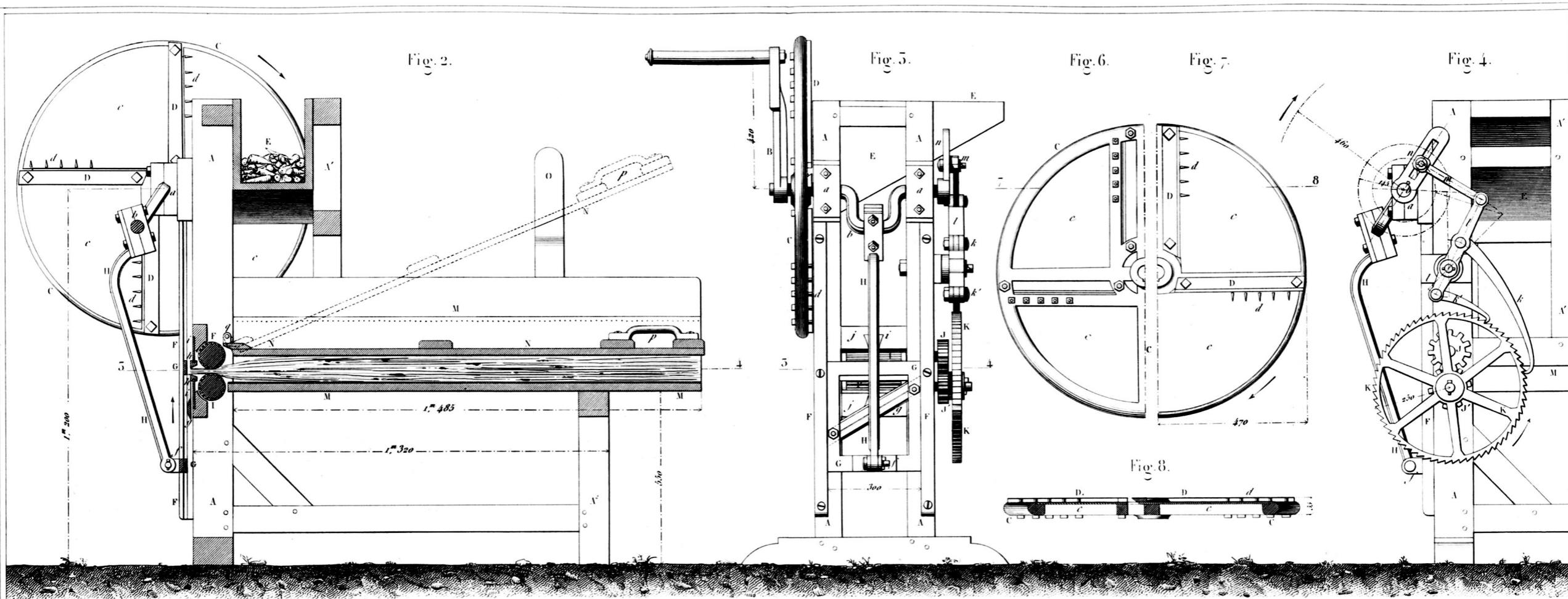
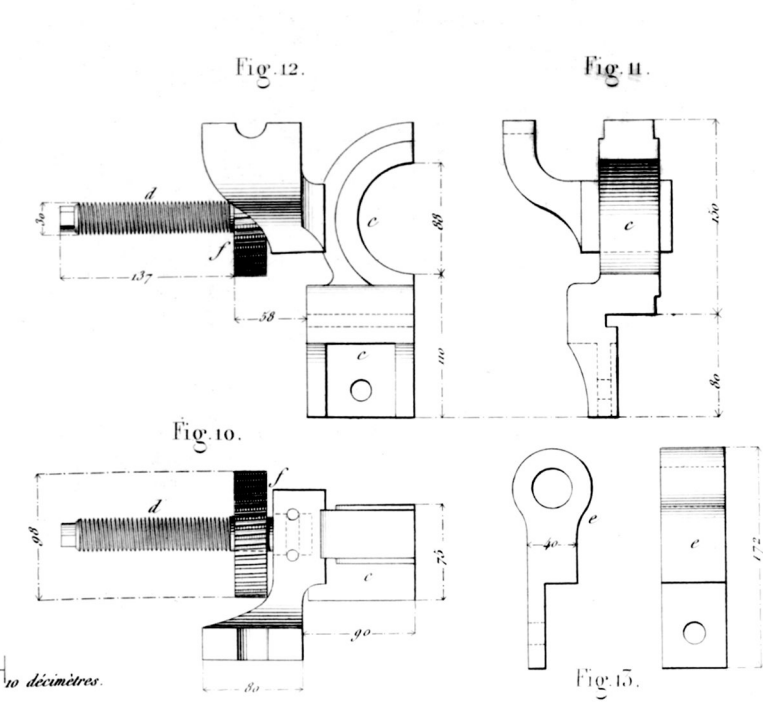
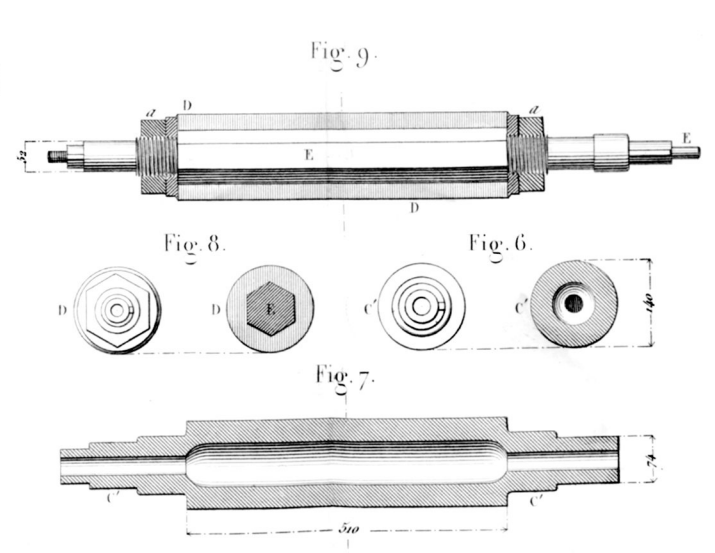
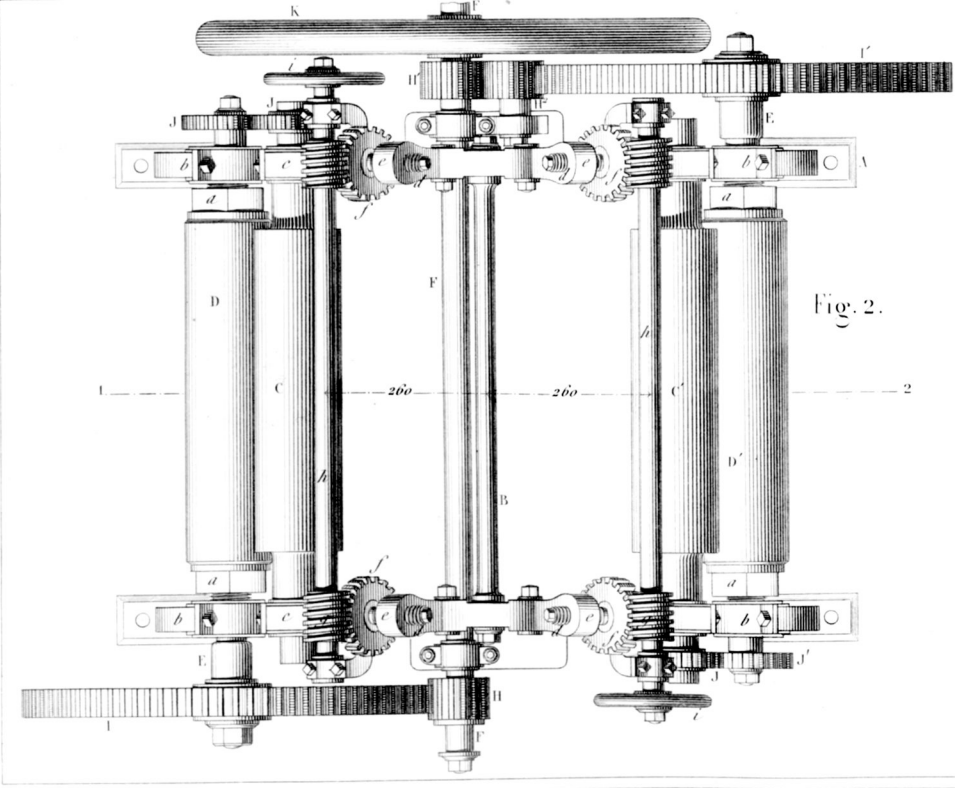
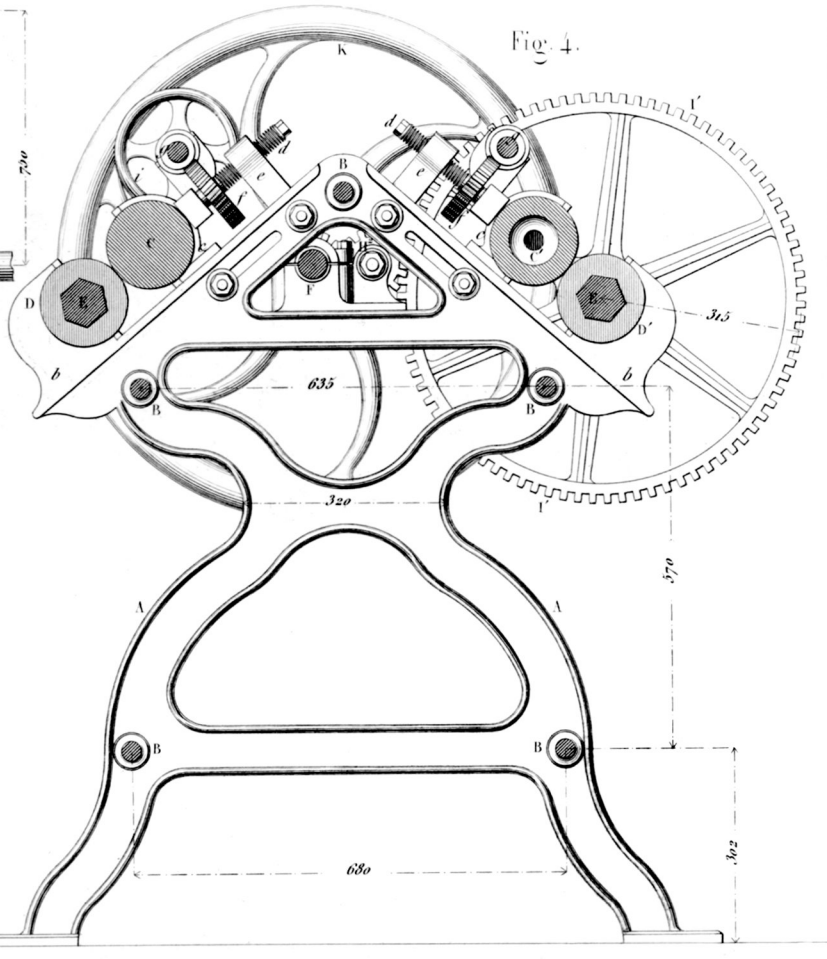
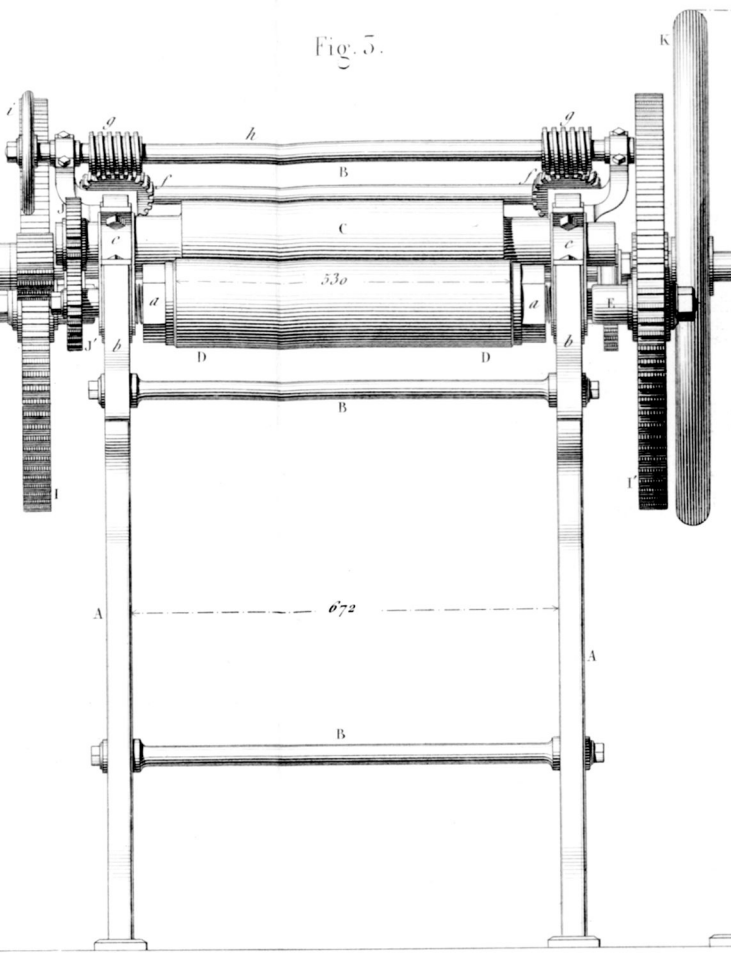
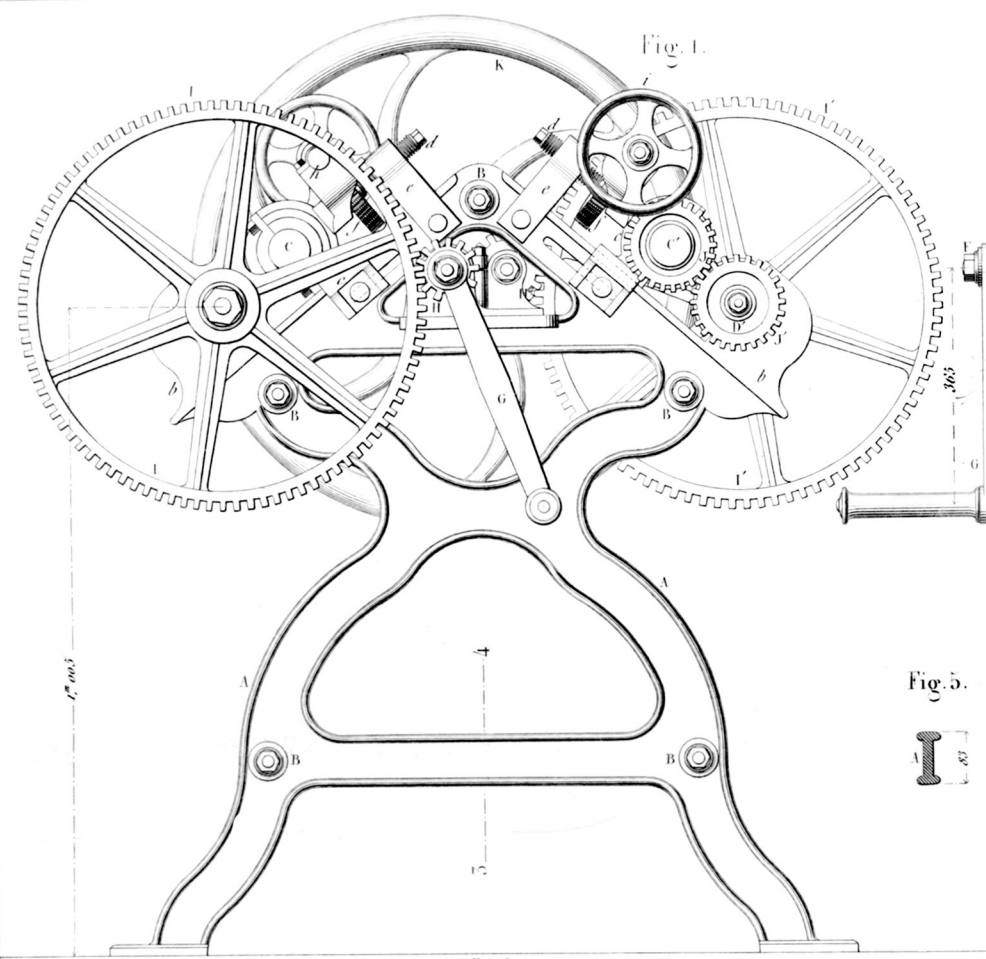

Fig. 8.







Echelle de 1/12^e pour Fig. 1 à 9.
 0 1 2 3 4 5 6 7 8 9 10 décimètres.

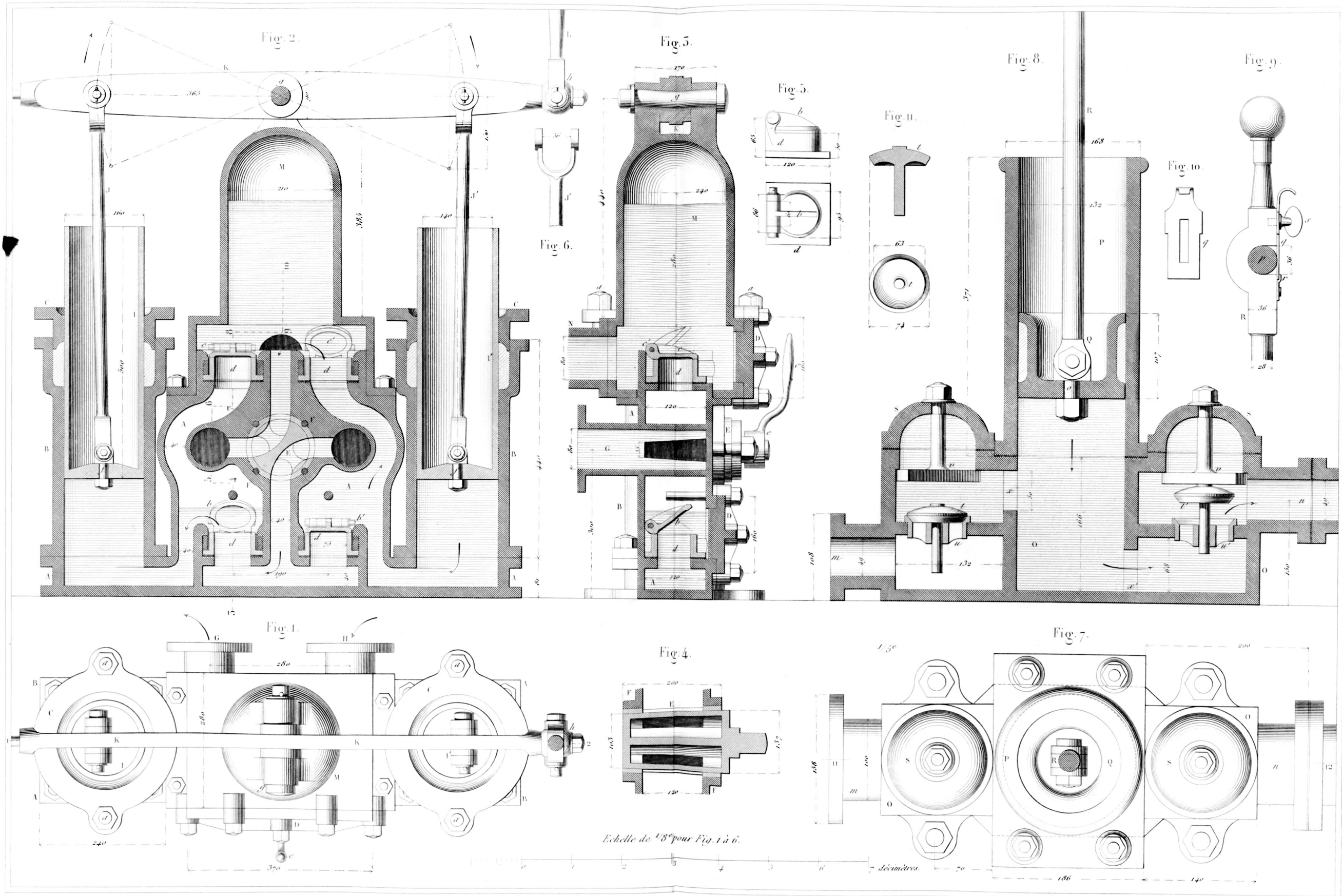

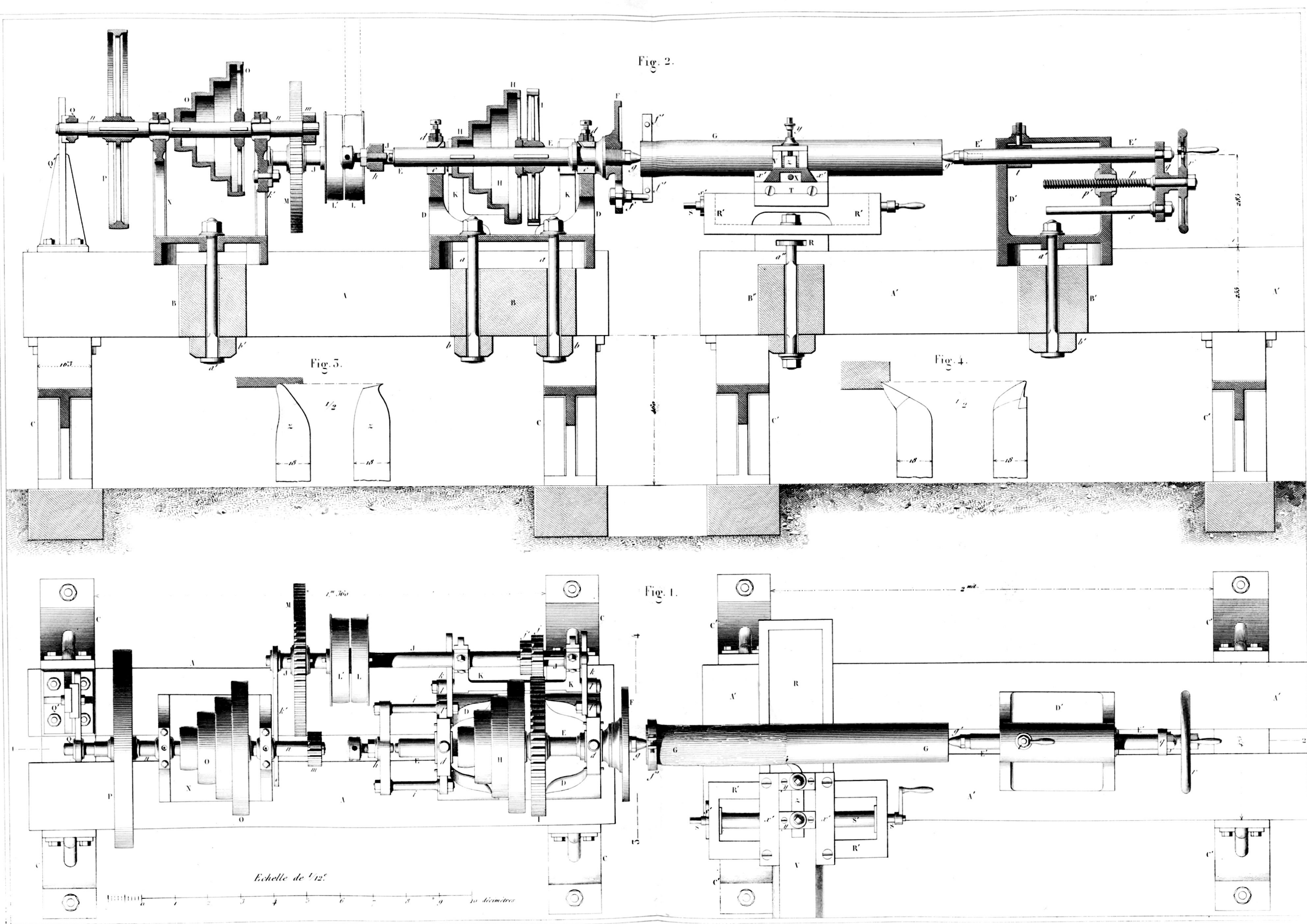

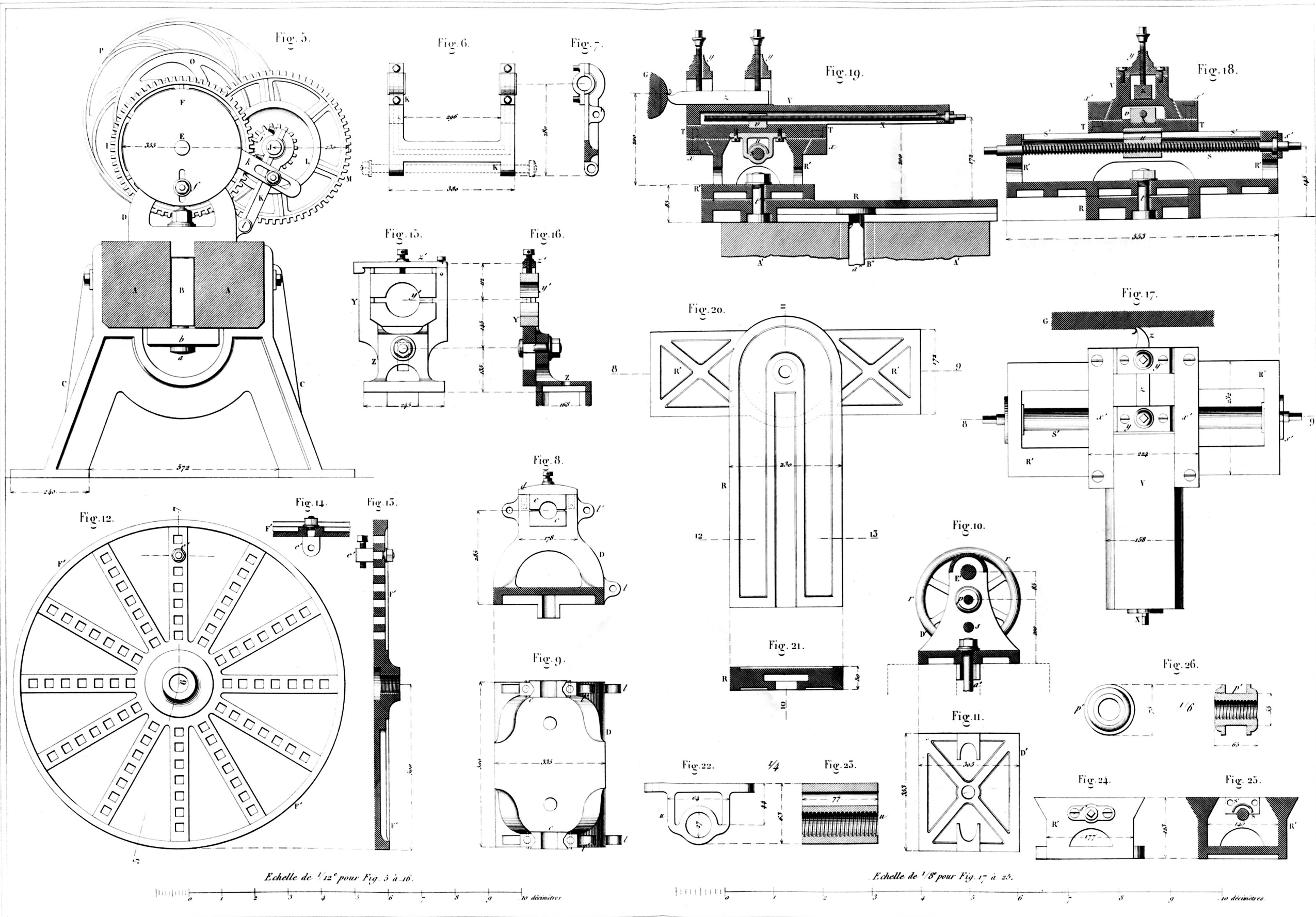

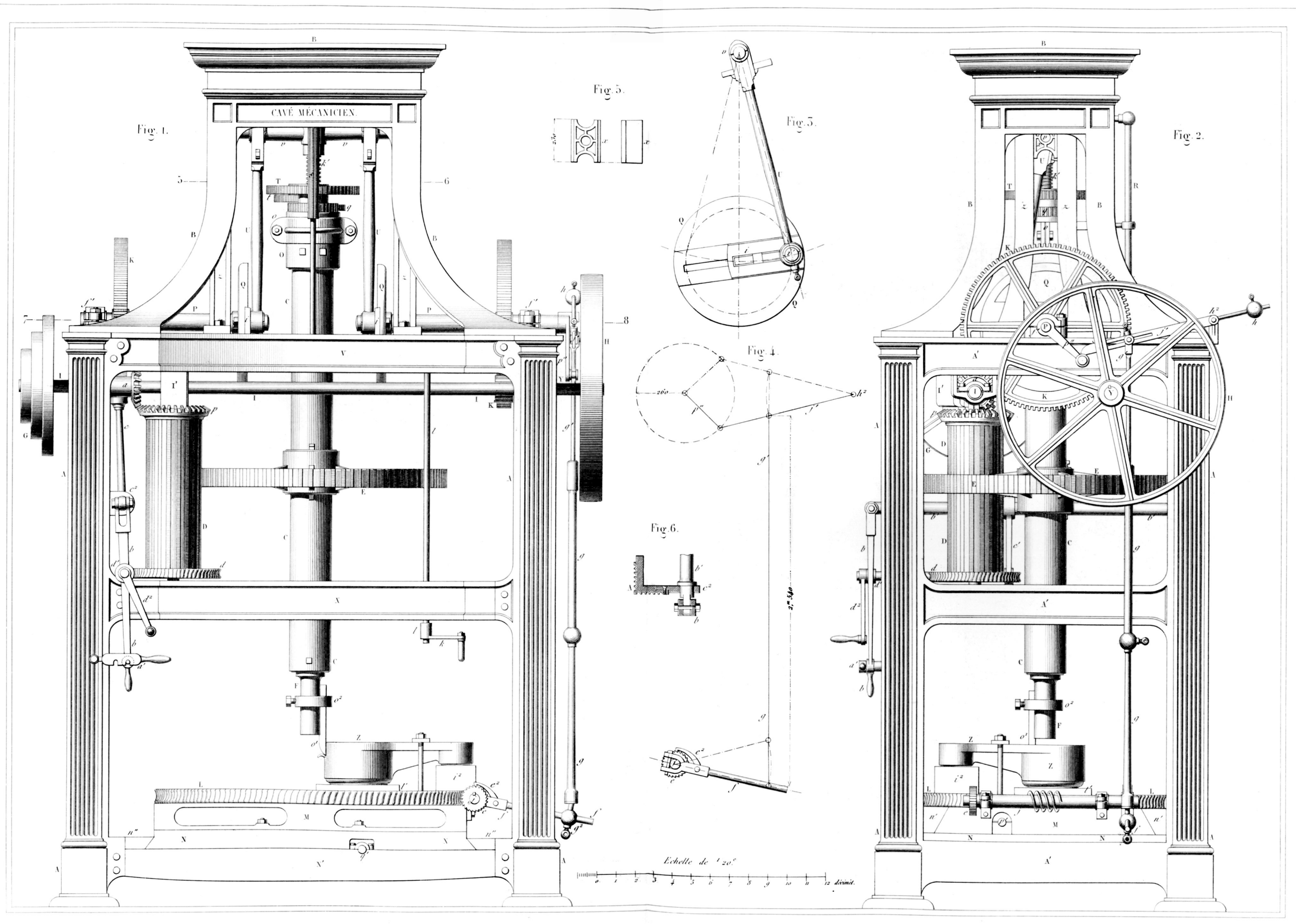

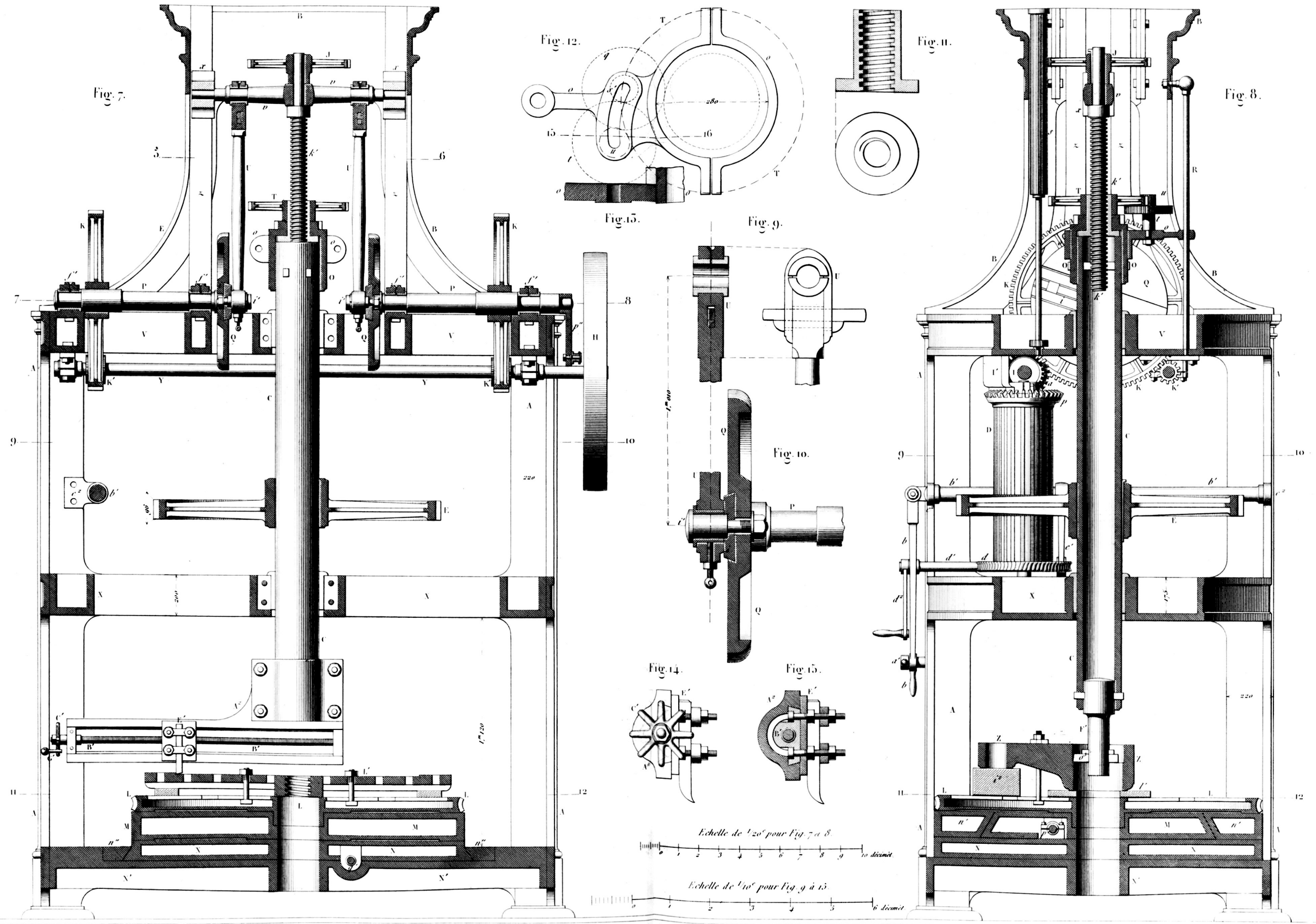

Fig. 16.

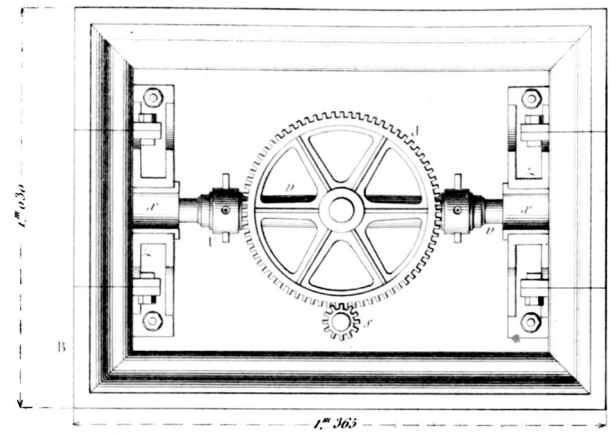

Fig. 17.

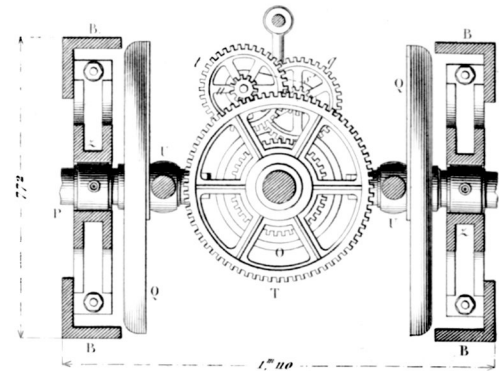

Fig. 18.

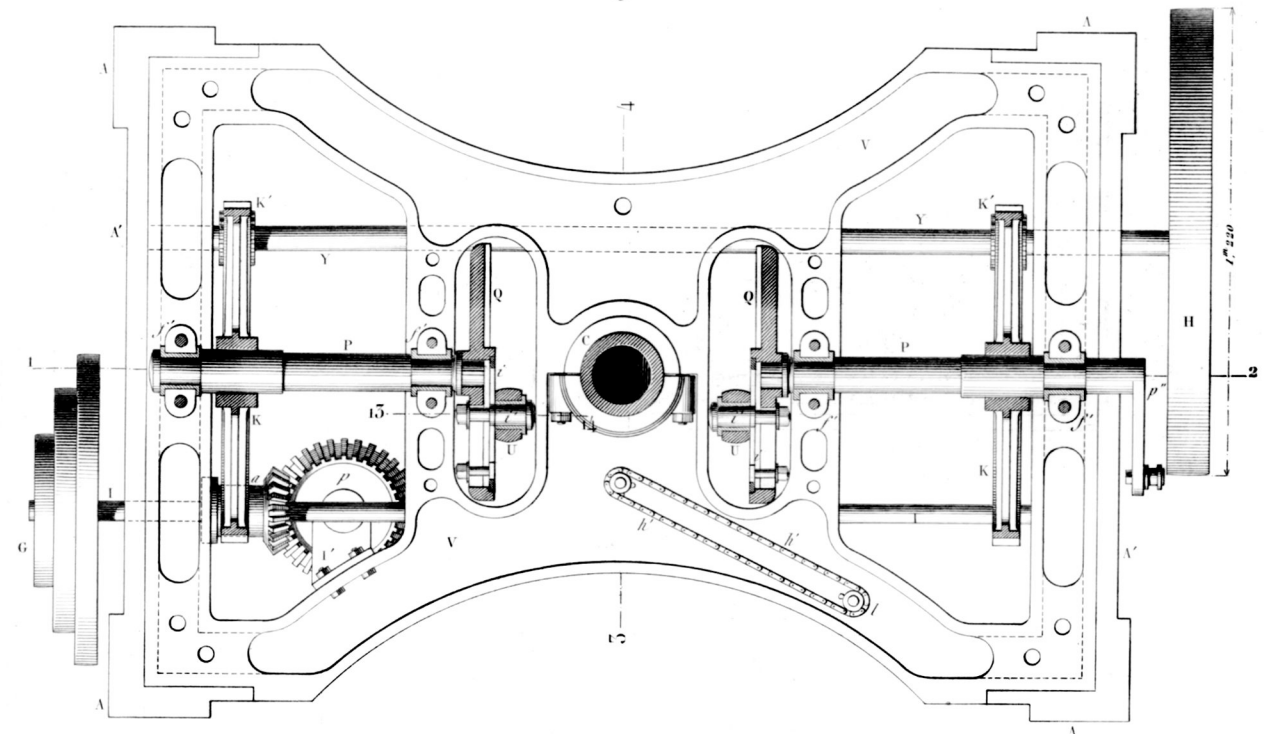

Fig. 20.

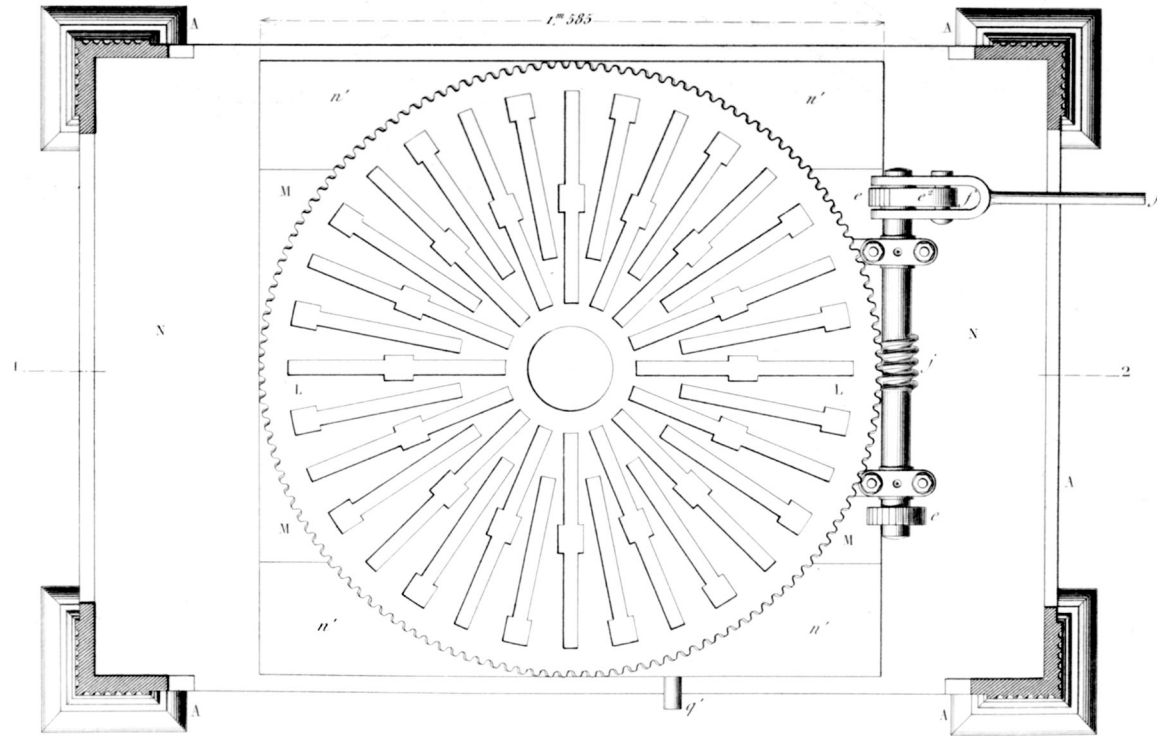

Fig. 21.

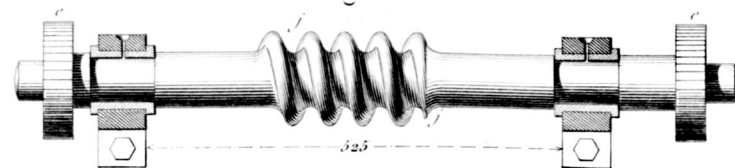
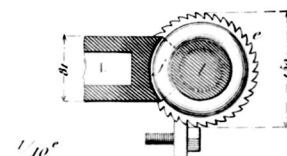
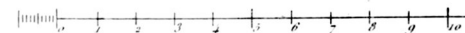

Fig. 22.



Echelle de 1/20^e



2 décimètres.

Fig. 19.

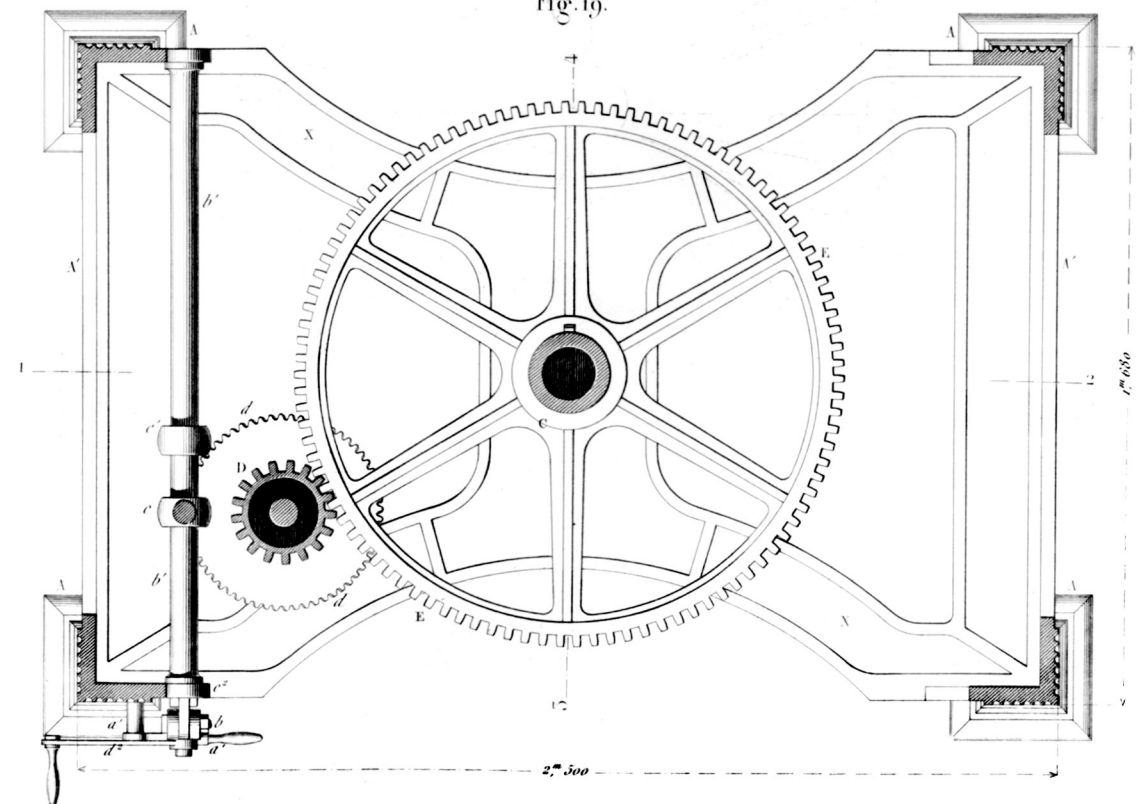

Machine de M. Carville.

Machine de M. Capouillet.

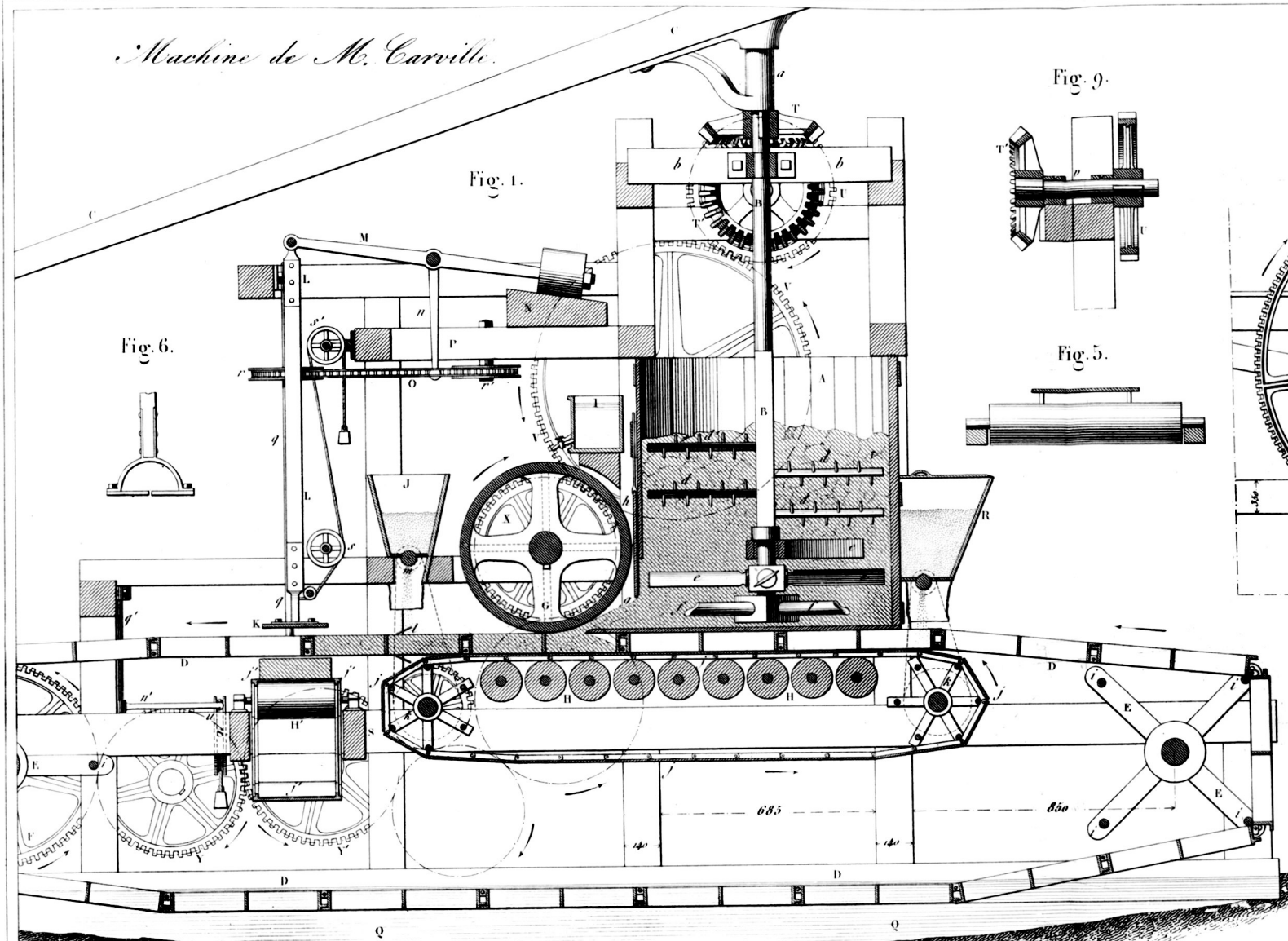

Fig. 6.

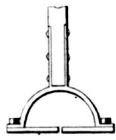

Fig. 1.

Fig. 9.

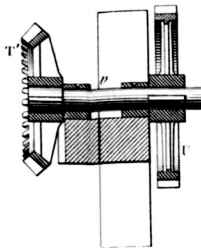

Fig. 5.

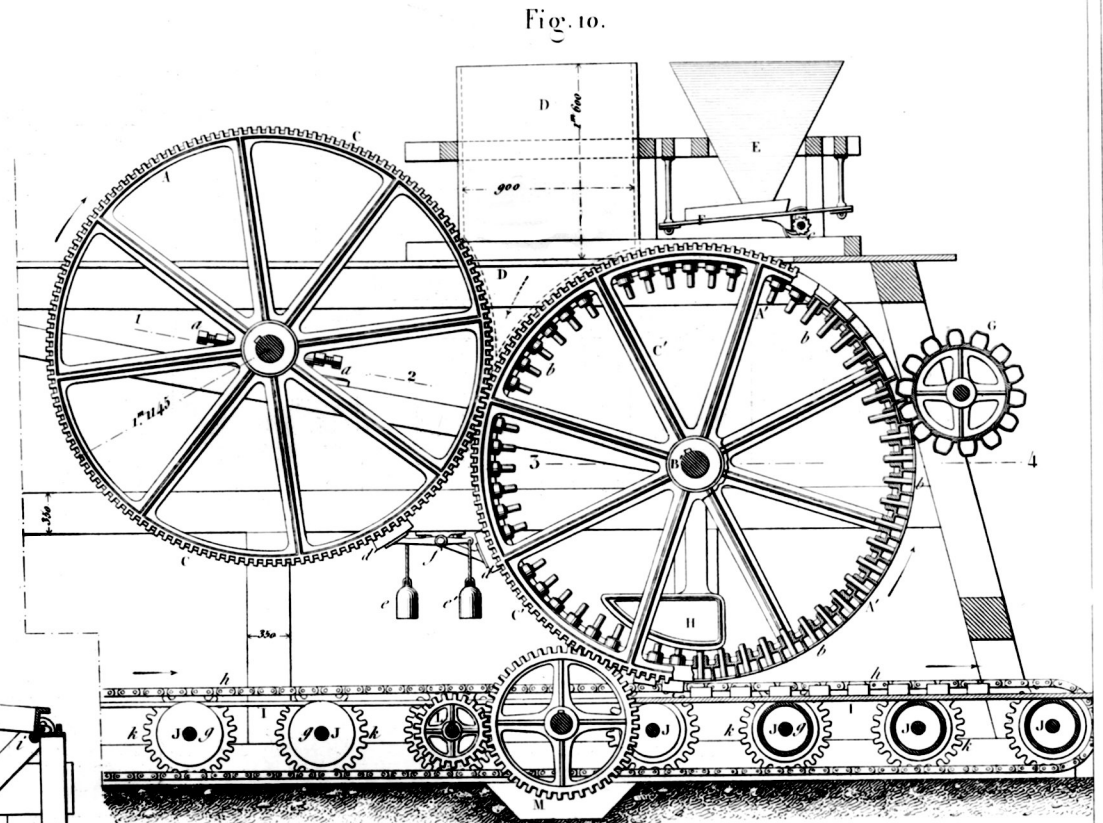

Fig. 10.

Echelle de 1/40^e pour Fig. 10 à 12.



Fig. 11.

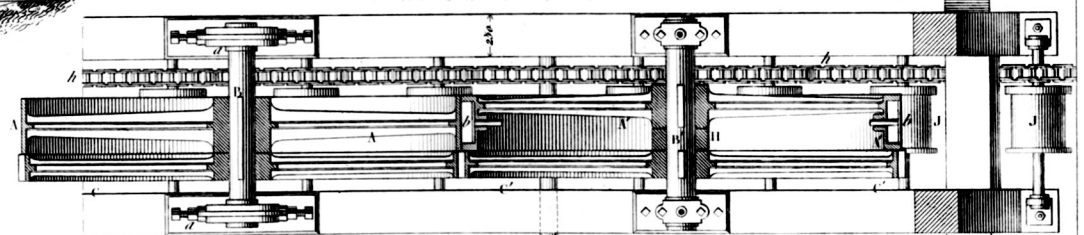

Fig. 12.

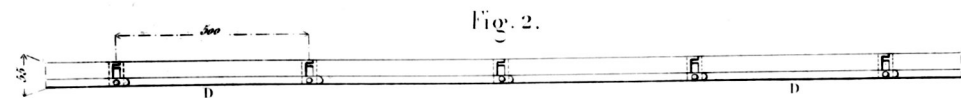
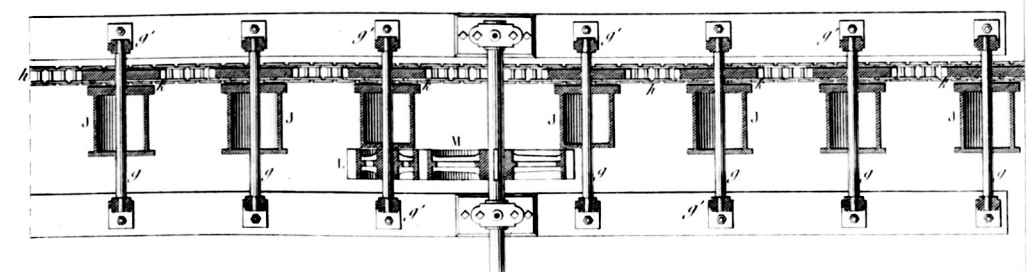

Fig. 2.

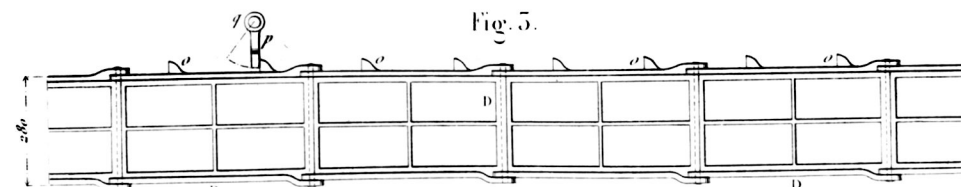

Fig. 5.

Echelle de 1/20^e pour Fig. 1 à 9.

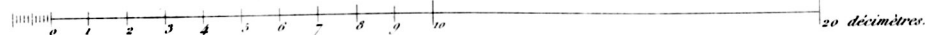

Fig. 4.

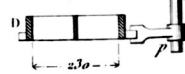

Fig. 8.

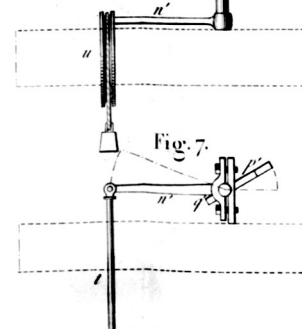
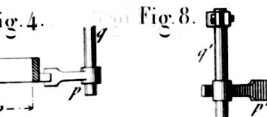
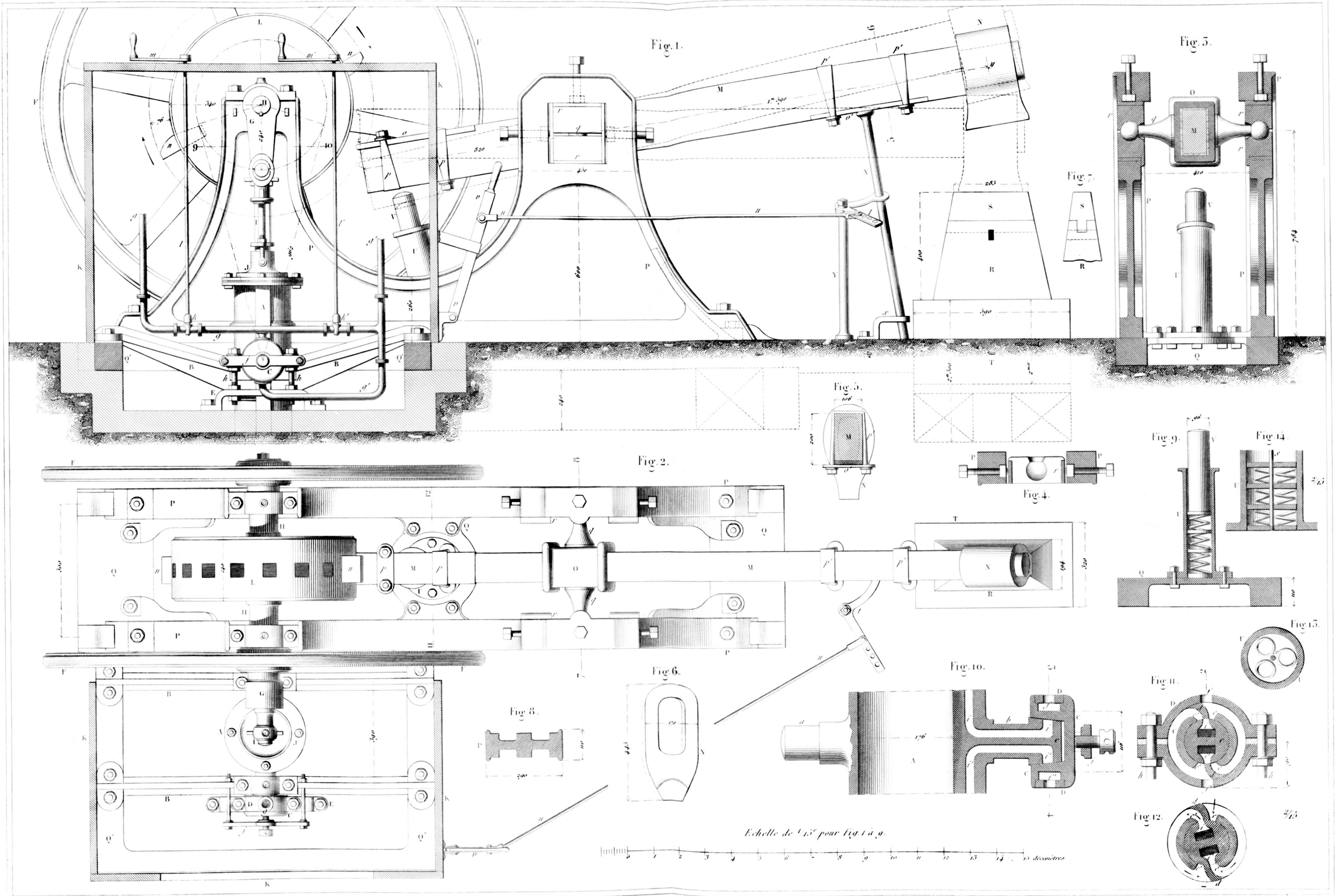
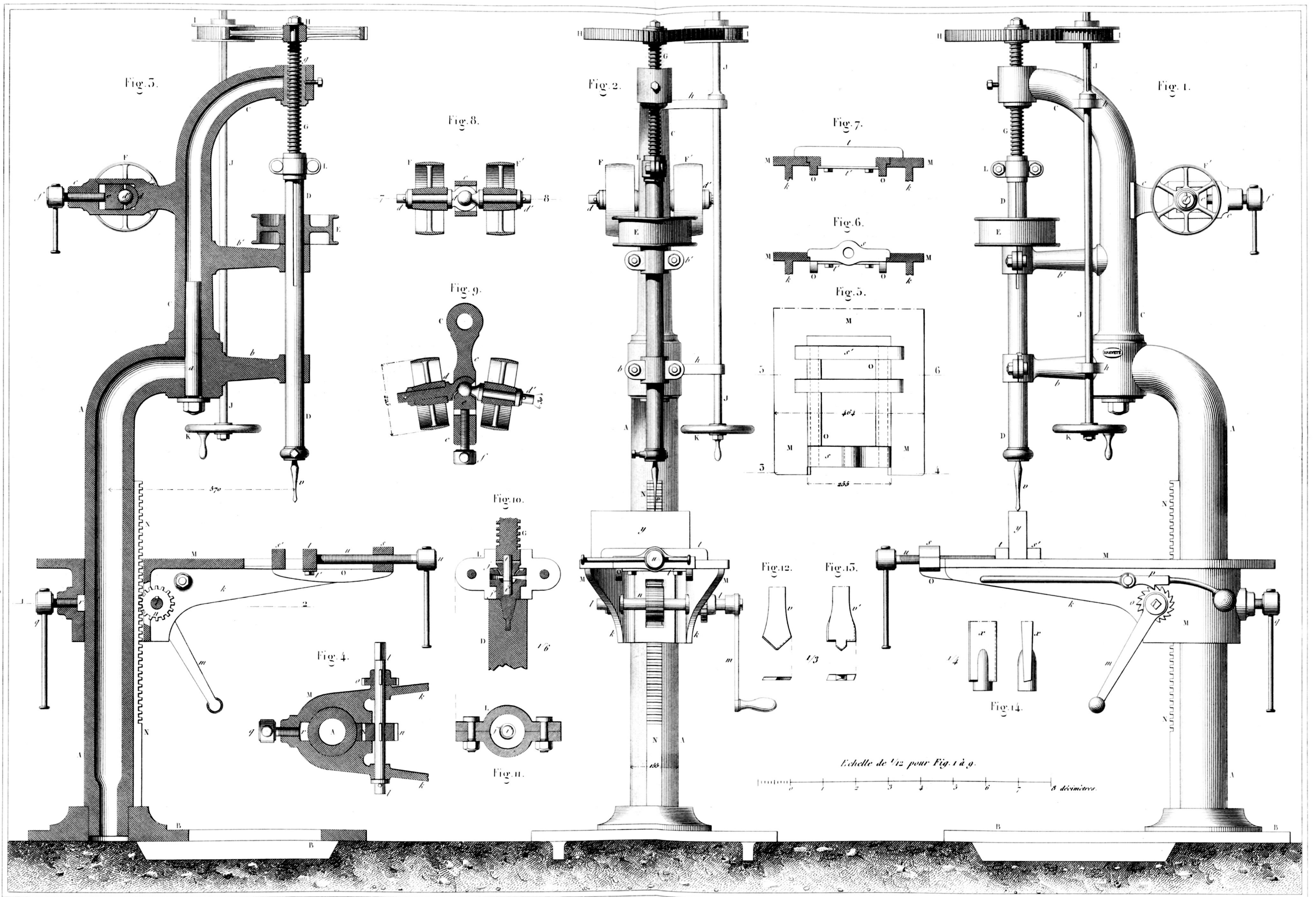
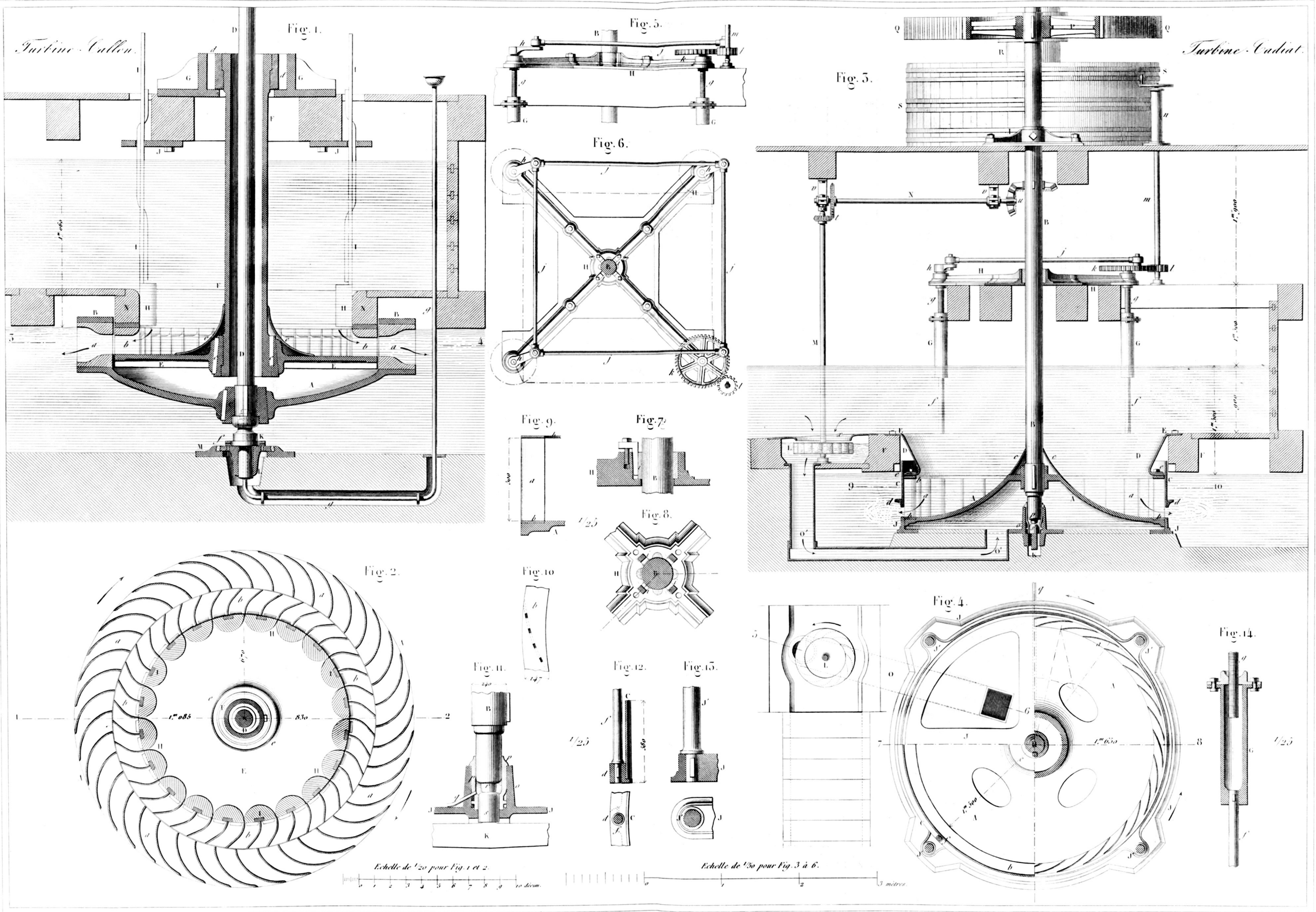
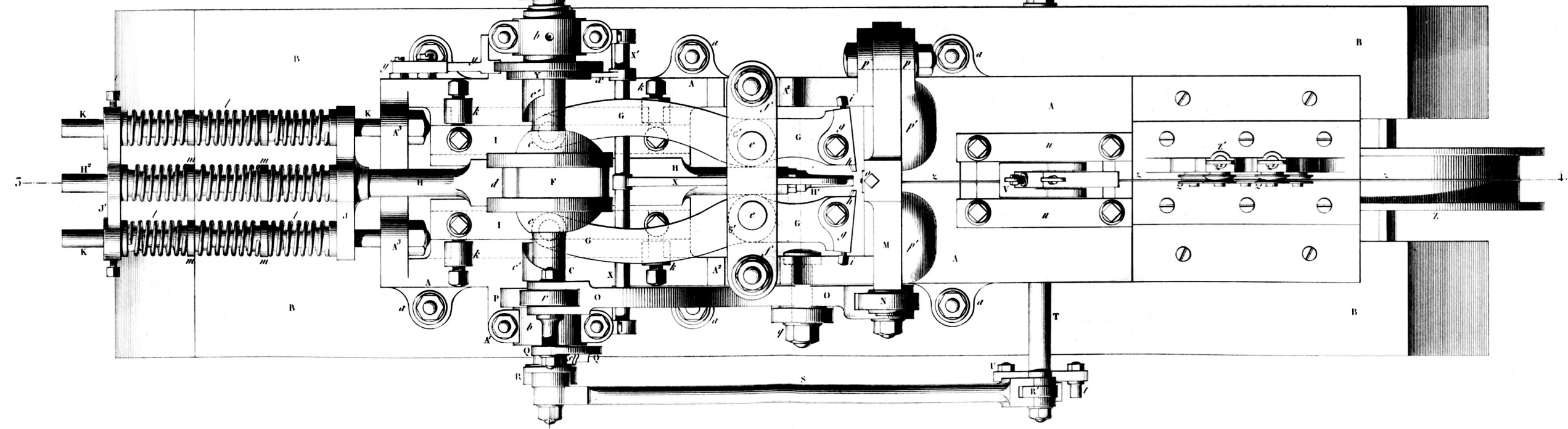
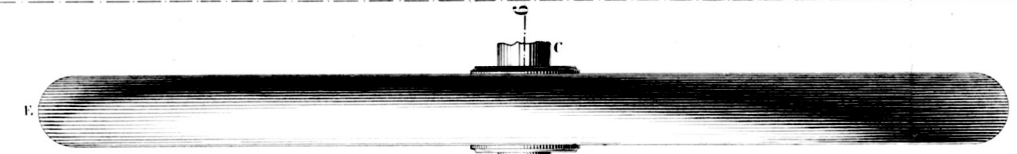
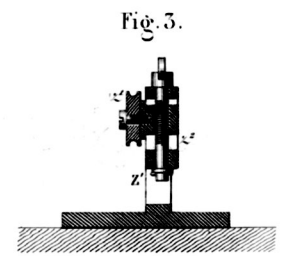
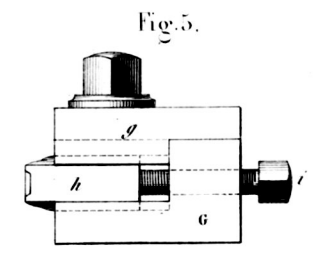
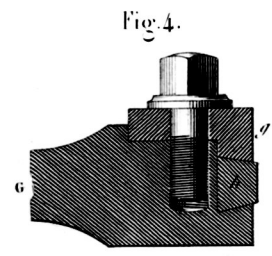
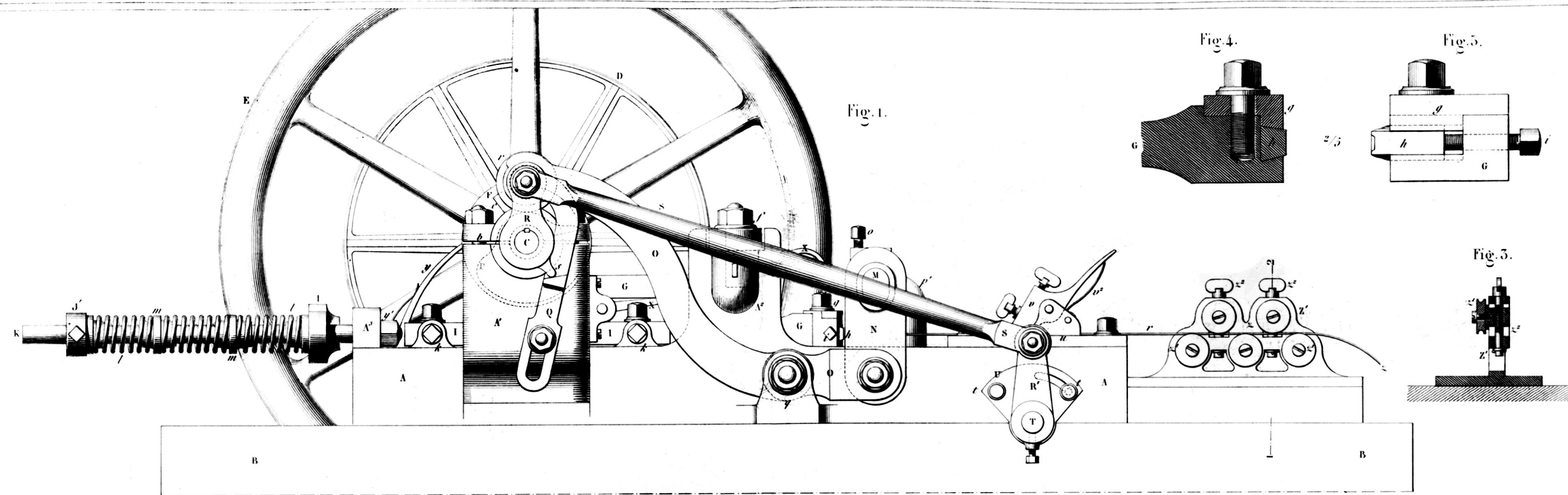

Fig. 7.









Echelle de 1/5 pour Fig. 1, 2 et 3.

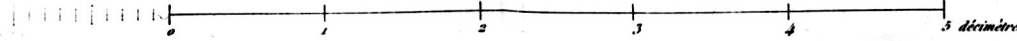

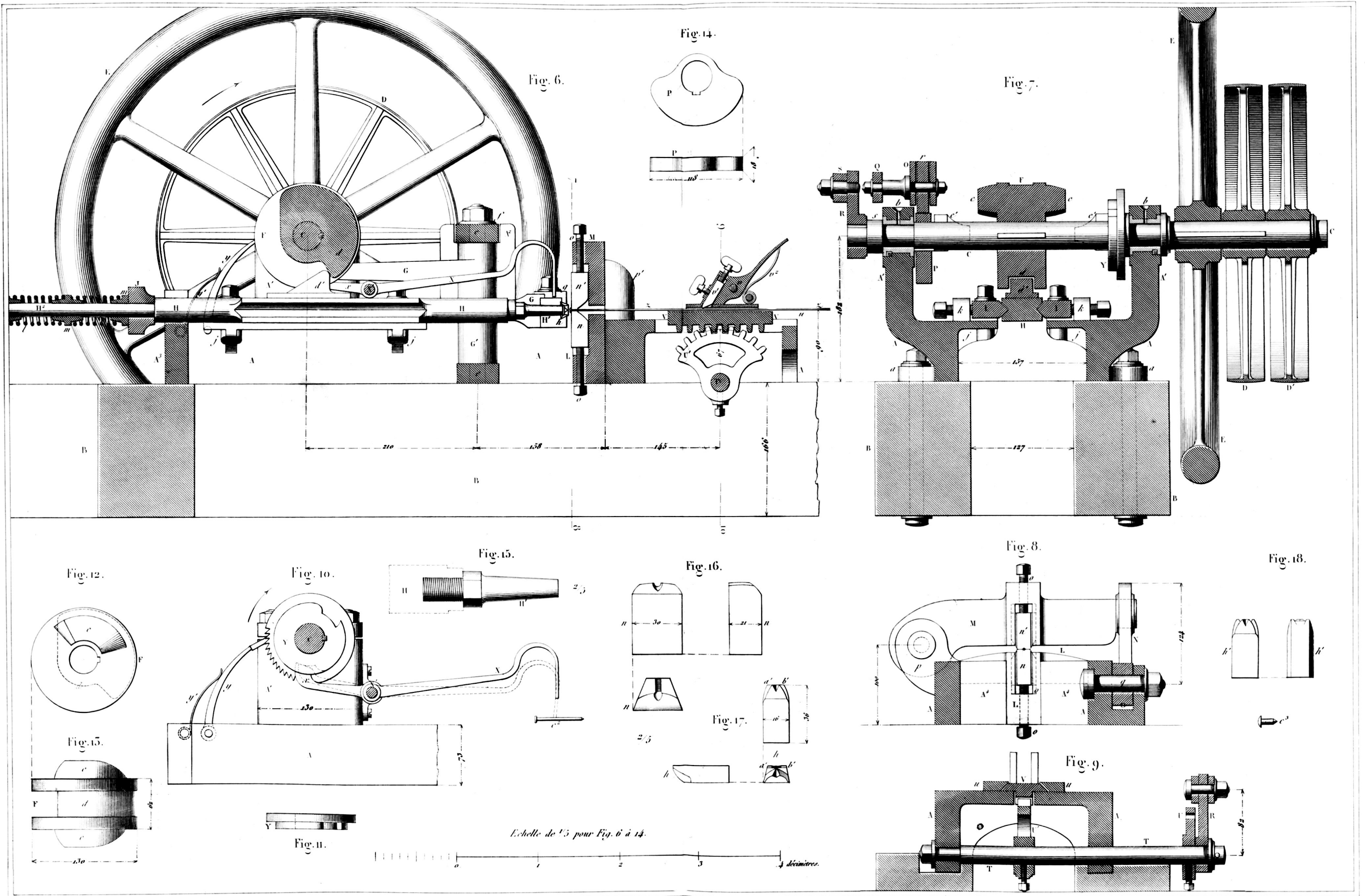

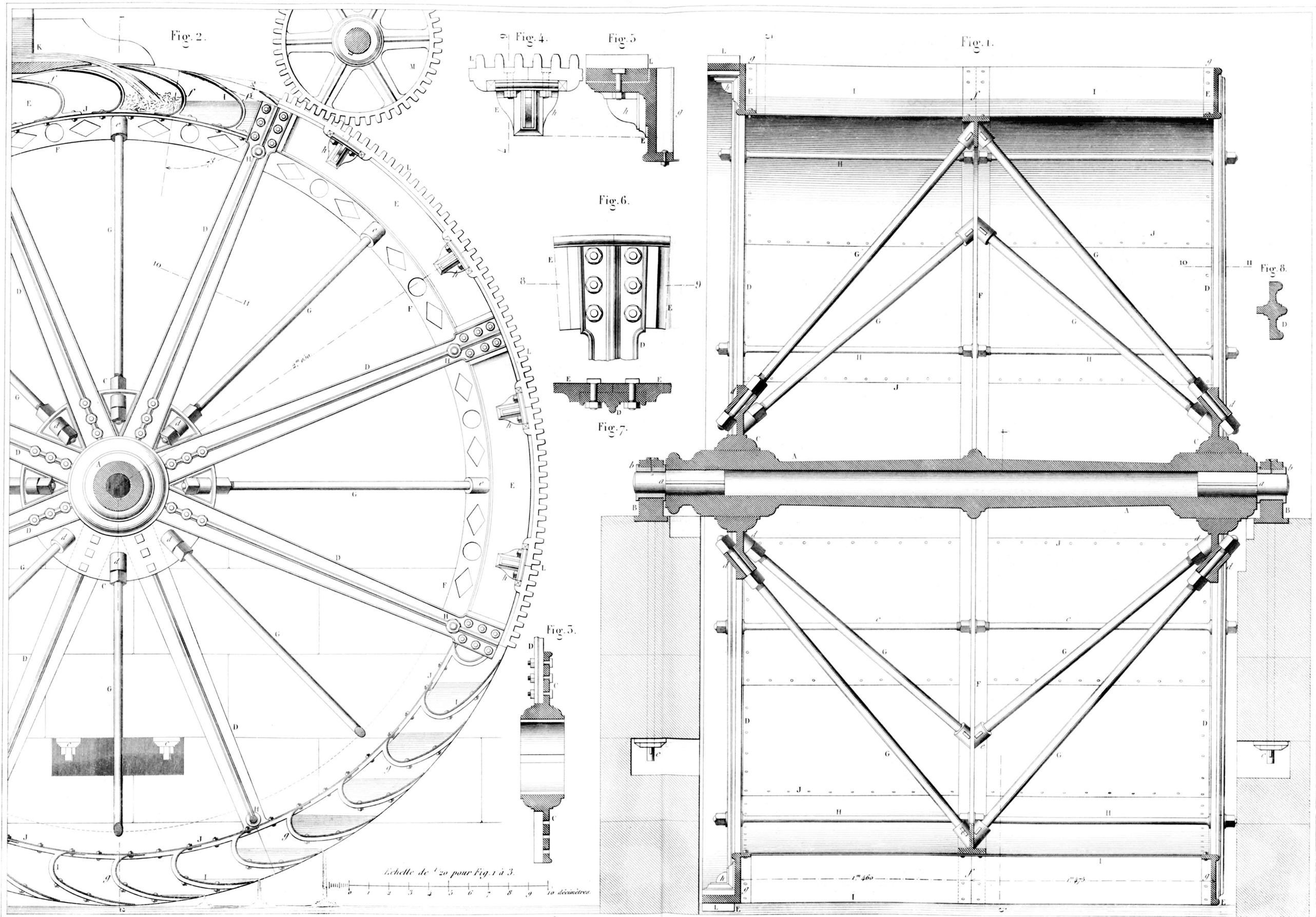

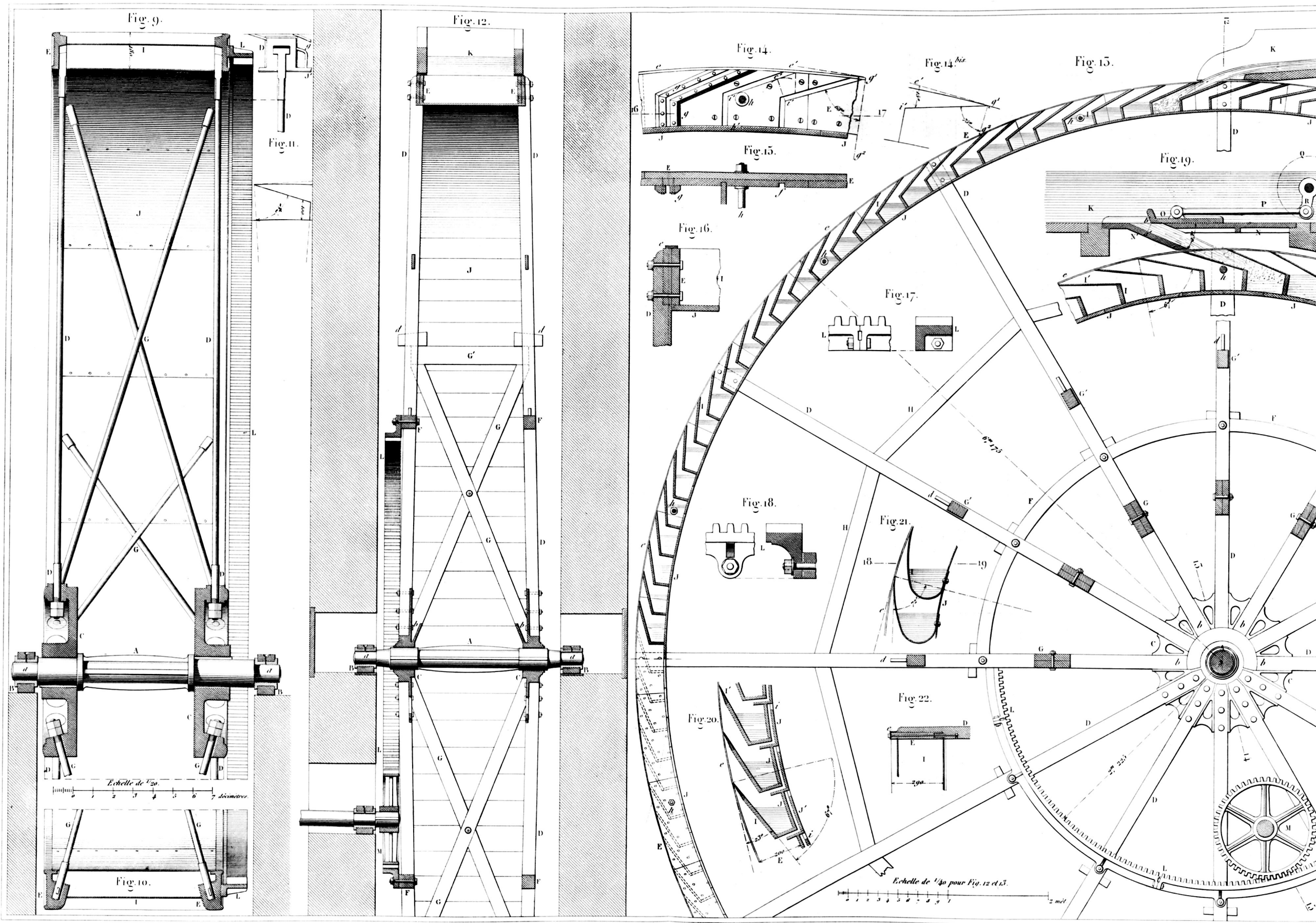

Fig. 1.

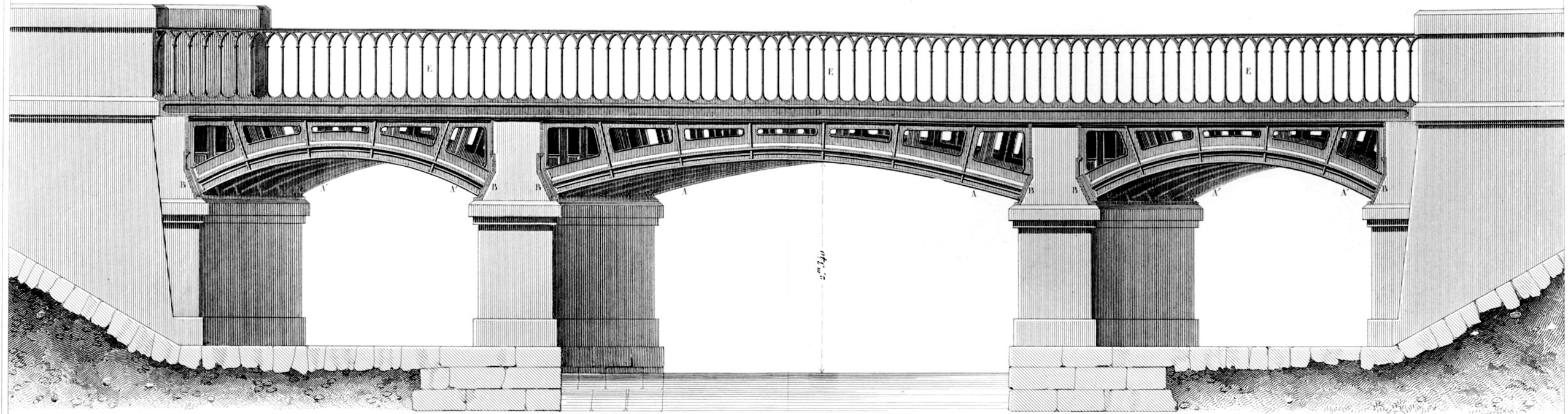
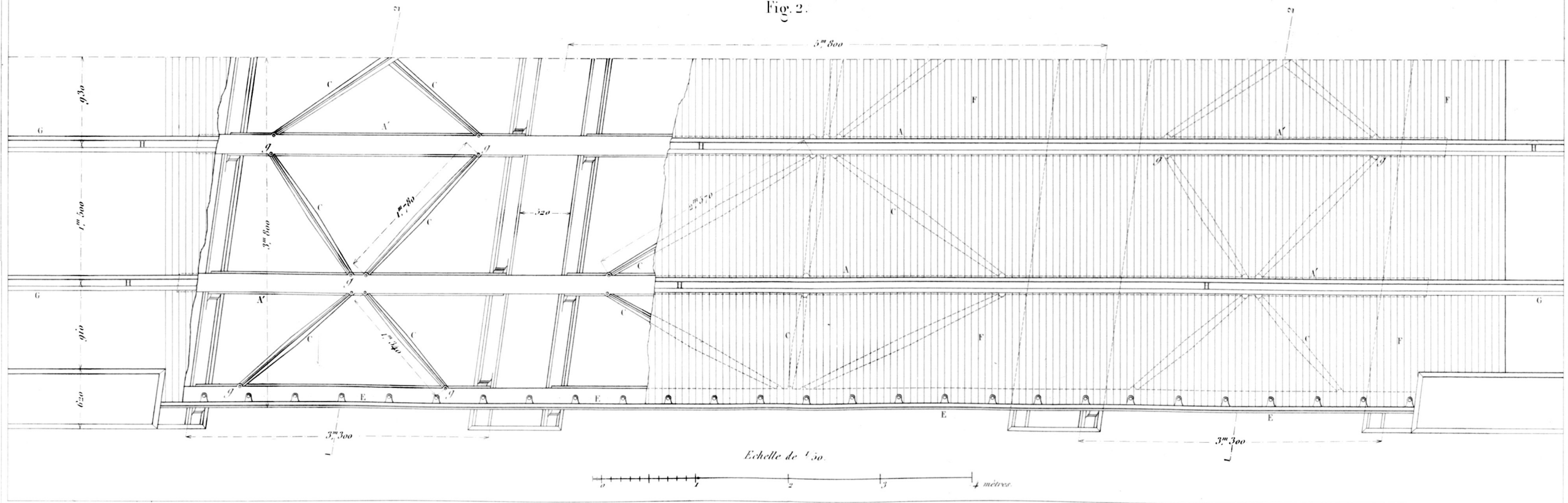
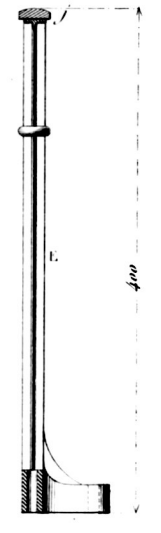
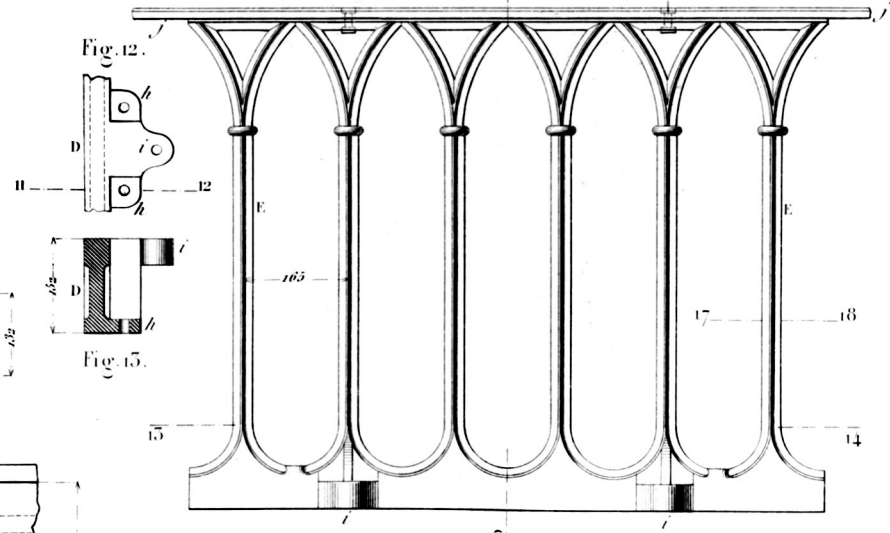
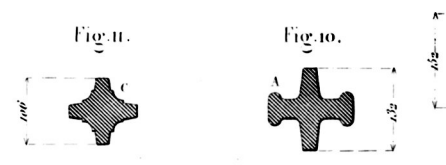
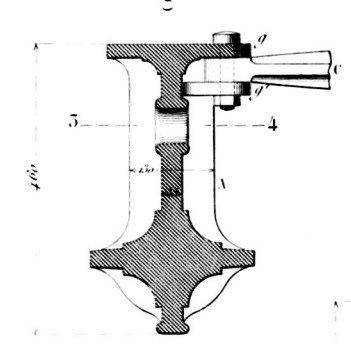
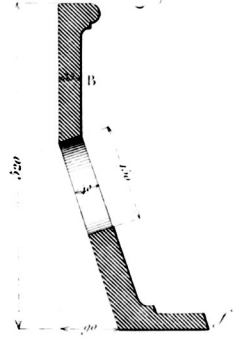
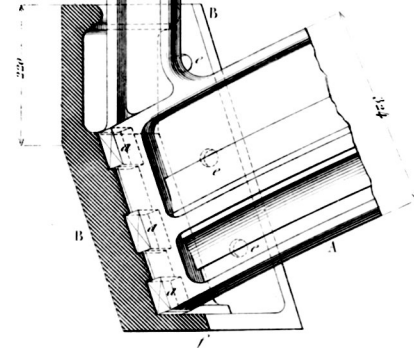
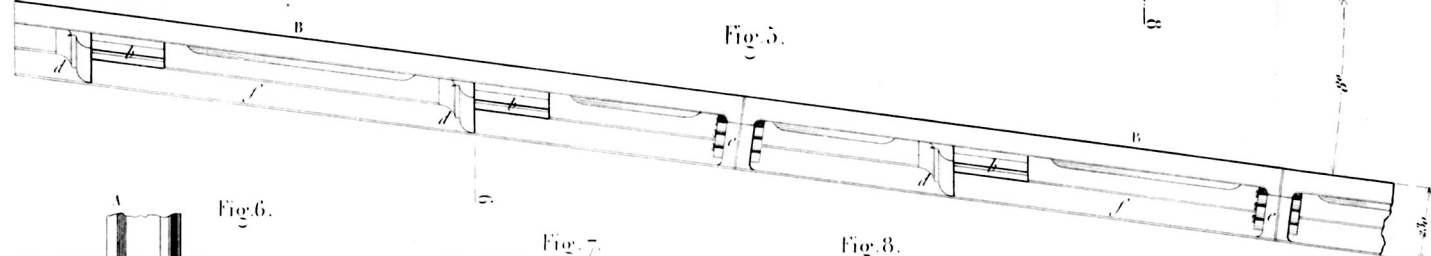
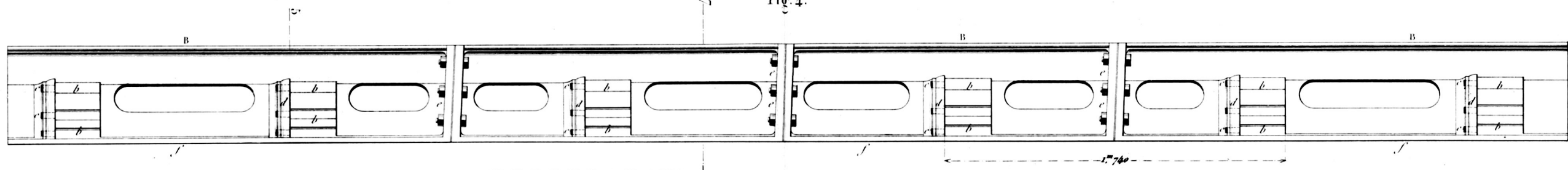
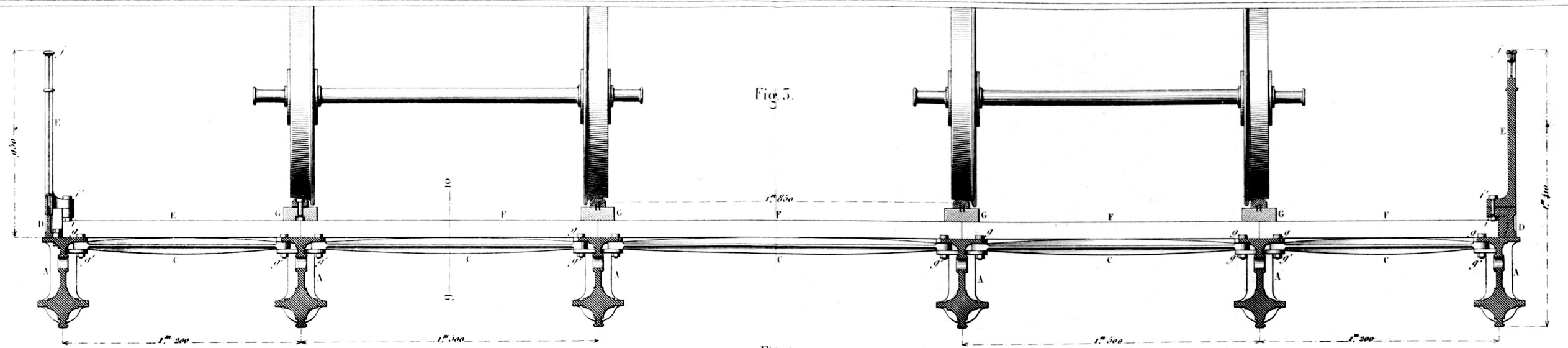

Fig. 2.





Echelle de 1/25 pour les Fig. 3, 4 et 5.
2 mètres.







BIBLIOTEKA GŁÓWNA

100073N/1